

Service
Service
Service



Service Manual

TABLE OF CONTENTS

	Page
Specifications	1-2
Measurement Setup	1-3
Service Aids, Safety Instruction, etc	1-4
CD Playability Check	1-5 to 1-7
Block Diagram	2
Wiring Diagram.....	3
Cassette Board & USB Board	4
Main & USB Board	5
CD Board.....	6
AMP Board	7
Mechanical Exploded View & Parts List	8
Revision List	9



© Copyright 2007 Philips Consumer Electronics B.V. Eindhoven, The Netherlands
All rights reserved. No part of this publication may be reproduced, stored in a retrieval system or transmitted, in any form or by any means, electronic, mechanical, photocopying, or otherwise without the prior permission of Philips.

Published by SL0731 Service Audio

Printed in The Netherlands Subject to modification.



3141 785 31682



Version 1.2



PHILIPS

SPECIFICATION

AMPLIFIER

1 KHz
(Low channel - both channels driven)
..... 30 W per channel (8 Ω)
10 KHz
(High channel - both channels driven)
..... 30 W per channel (8 Ω)
Total output power 120 W
Signal-to-noise ratio \geq 62 dBA (IEC)
Frequency response 63 – 16000 Hz, \pm 3 dB

CD PLAYER

Frequency range 63 – 16000 Hz
Signal-to-noise ratio 65 dBA

TUNER

FM wave range 87.5 – 108 MHz
MW wave range 531 – 1602 kHz

TAPE DECK

Frequency response
Normal tape (type I) 125 – 8000 Hz (8 dB)
Signal-to-noise ratio
Normal tape (type I) 35 dBA
Wow and flutter \leq 0.4% DIN

USB PLAYER

USB 12Mb/s, V1.1
..... support MP3 and WMA files
Number of albums/folders maximum 99
Number of tracks/titles maximum 400

SPEAKERS

2-way Bass Reflex System
Impedance 8 Ω
Woofer 1x10 cm
Tweeter 1x5 cm
Dimensions (w x h x d) 21.5x34.9x16.2 (cm)

GENERAL

AC Power 220 – 230 V / 50 Hz
Dimensions (w x h x d) 22x29.2x27.2 (cm)
Weight (with/without speakers)
..... approx. 4.9 / 2.3 kg

Specifications and external appearance are subject to change without notice.

MEASUREMENT SETUP

Tuner FM

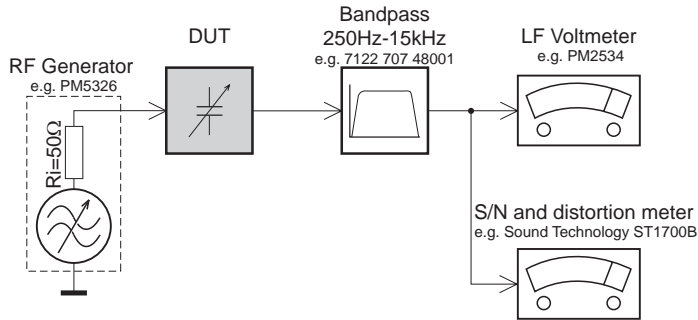

Use a bandpass filter to eliminate hum (50Hz, 100Hz) and disturbance from the pilotone (19kHz, 38kHz).

Tuner AM (MW,LW)

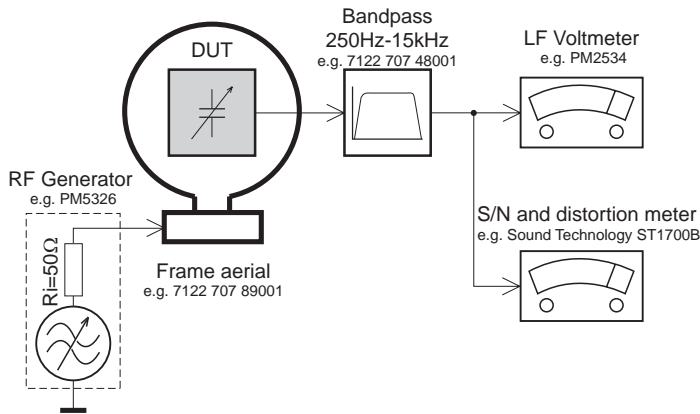

To avoid atmospheric interference all AM-measurements have to be carried out in a Faraday's cage. Use a bandpass filter (or at least a high pass filter with 250Hz) to eliminate hum (50Hz, 100Hz).

CD

Use Audio Signal Disc SBC429 4822 397 30184
(replaces test disc 3)

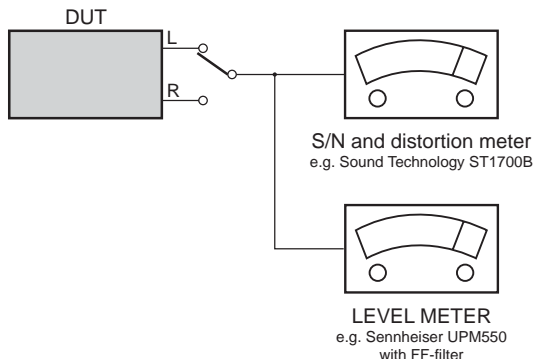

Recorder

Use Universal Test Cassette **CrO2** SBC419 4822 397 30069
or Universal Test Cassette **Fe** SBC420 4822 397 30071

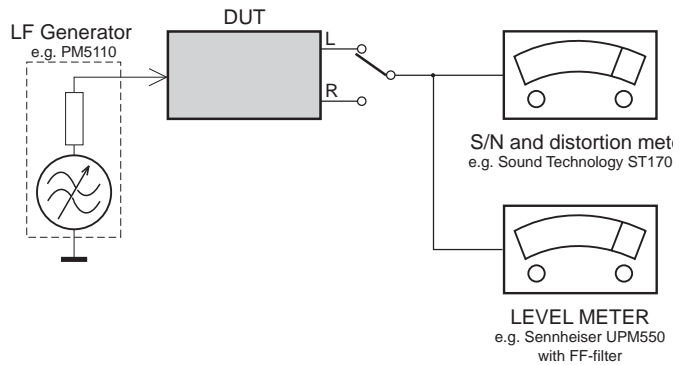

SERVICE AIDS

Service Tools:

Universal Torx driver holder	4822 395 91019
Torx bit T10 150mm	4822 395 50456
Torx driver set T6-T20	4822 395 50145
Torx driver T10 extended	4822 395 50423

Compact Disc:

SBC426/426A Test disc 5 + 5A	4822 397 30096
SBC442 Audio Burn-in test disc 1kHz	4822 397 30155
SBC429 Audio Signals disc	4822 397 30184
Dolby Pro-logic Test Disc	4822 395 10216



WARNING

All ICs and many other semi-conductors are susceptible to electrostatic discharges (ESD). Careless handling during repair can reduce life drastically.
When repairing, make sure that you are connected with the same potential as the mass of the set via a wrist wrap with resistance. Keep components and tools also at this potential.

ESD



Safety regulations require that the set be restored to its original condition and that parts which are identical with those specified, be used

Safety components are marked by the symbol .

**CLASS 1
LASER PRODUCT**

INFORMATION ABOUT LEAD-FREE SOLDERING

Philips CE is producing lead-free sets from 1.1.2005 onwards.

IDENTIFICATION:

Regardless of special logo (not always indicated) one must treat all sets from 1 Jan 2005 onwards, according next rules:



- On our website www.atyourservice.ce.Philips.com you find more information to:
 - * BGA-de-/soldering (+ baking instructions)
 - * Heating-profiles of BGAs and other ICs used in Philips-sets
 - * Lead free

You will find this and more technical information within the "magazine", chapter "workshop news".

For additional questions please contact your local repair-helpdesk.

SERVICE INSTRUCTION

Safety regulations require that after a repair, the set must be returned in its original condition. Pay in particular attention to the following points:

- Route the wire trees correctly and fix them with the mounted cable clamps.
- Check the insulation of the AC Power lead for external damage.
- Check the strain relief of the AC Power cord for proper function.
- Check the electrical DC resistance between the AC Power Plug and the secondary side (only for sets which have a AC Power isolated power supply):
 1. Unplug the AC Power cord and connect a wire between the two pins of the AC Power plug.
 2. Set the AC Power switch to the "on" position (keep the AC Power cord unplugged!).
 3. Measure the resistance value between the pins of the AC Power plug and the metal shielding of the tuner or the aerial connection on the set. The reading should be larger than 4.5 Mohm (For U.S. it should be between 4.2 Mohm and 12 Mohm).
 4. Switch "off" the set, and remove the wire between the two pins of the AC Power plug.
- Check the cabinet for defects, to avoid touching of any inner parts by the customer.

INSTRUCTIONS ON CD PLAYABILITY

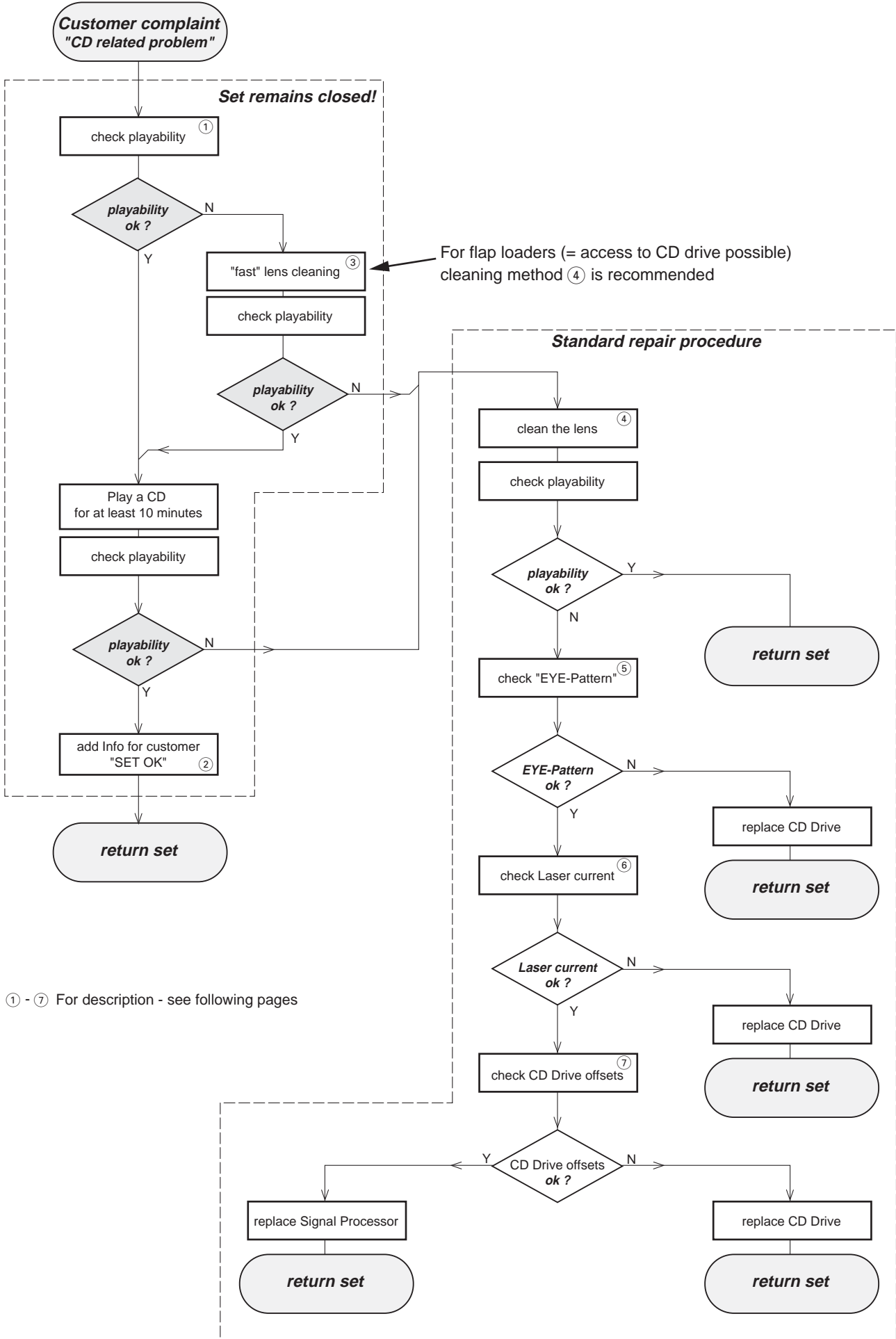

INSTRUCTIONS ON CD PLAYABILITY

①

PLAYABILITY CHECK

For sets which are compatible with **CD-RW** discs
 use CD-RW Printed Audio Disc.....7104 099 96611
 TR 3 (Fingerprint)
 TR 8 (600µ Black dot) **maximum at 01:00**

- playback of these two tracks without audible disturbance
 playing time for: Fingerprint ≥ 10 seconds
 Black dot from 00:50 to 01:10
- jump forward/backward (search) within a reasonable time

For all other sets
 use CD-DA SBC 444A.....4822 397 30245
 TR 14 (600µ Black dot) **maximum at 01:15**
 TR 19 (Fingerprint)
 TR 10 (1000µ wedge)

- playback of all these tracks without audible disturbance
 playing time for: 1000µ wedge ≥ 10 seconds
 Fingerprint ≥ 10 seconds
 Black dot from 01:05 to 01:25
- jump forward/backward (search) within a reasonable time

②

CUSTOMER INFORMATION

It is proposed to add an addendum sheet to the set which informs the customer that the set has been checked carefully - but no fault was found.
 The problem was obviously caused by a scratched, dirty or copy-protected CD. In case problems remain, the customer is requested to contact the workshop directly.
 The lens cleaning (method ③) should be mentioned in the addendum sheet.

The final wording in national language as well as the printing is under responsibility of the Regional Service Organizations.

③

FAST LENS CLEANING (dry brush)

Use lens cleaning CD
 SBC AC300.....9082 100 00043

Insert the lens cleaning CD, press PLAY and follow the voice guide's instructions on the CD.

④

LIQUID LENS CLEANING

Before touching the lens it is advised to clean the surface of the lens by blowing clean air over it. This to avoid that little particles make scratches on the lens.

Because the material of the lens is synthetic and coated with a special anti-reflectivity layer, cleaning must be done with a non-aggressive cleaning fluid. It is advised to use "Cleaning Solvent B4-No2", available with codenumber 4822 389 10026.

The actuator is a very precise mechanical component and may not be damaged in order to guarantee its full function. Clean the lens gently (don't press too hard) with a soft and clean cotton bud moistened with the special lens cleaner.

The direction of cleaning must be in the way as indicated in the picture below.

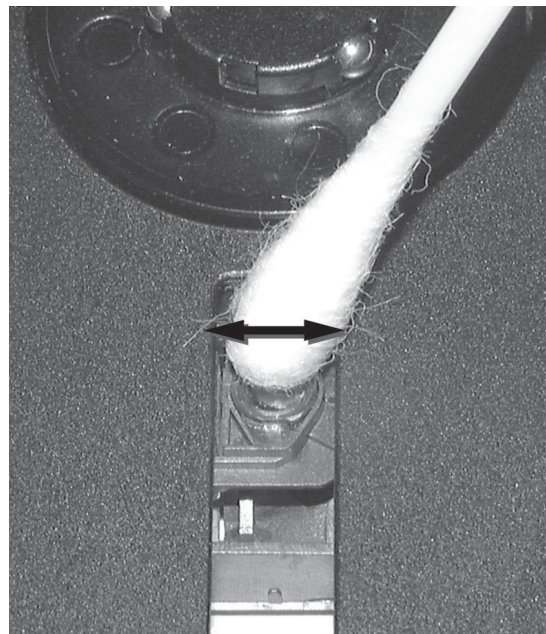

INSTRUCTIONS ON CD PLAYABILITY

5

EYE-PATTERN SIGNAL – JITTER MEASUREMENT

Measure the signal on the input of the Signal processor using an **analog** oscilloscope. Please find the exact measuring point in your Service Manual.

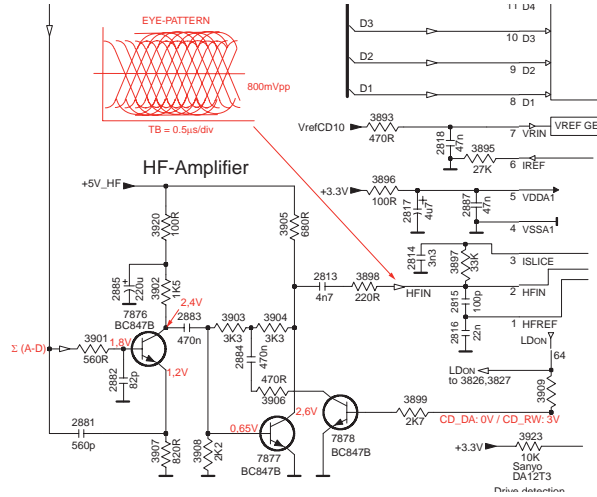

See below examples of the signal. Amplitude should read at least 700mVpp using SBC444A.

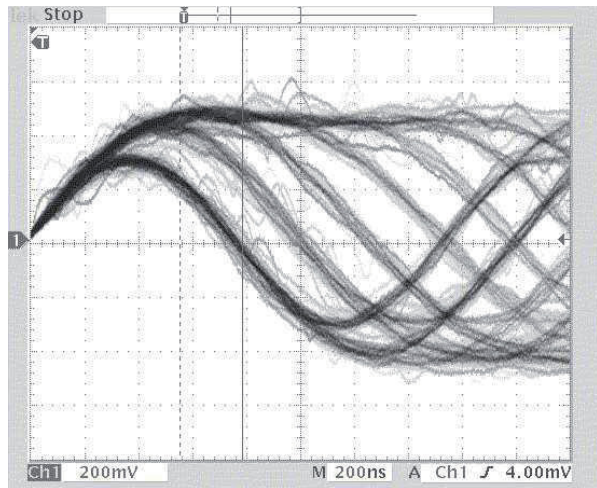

good

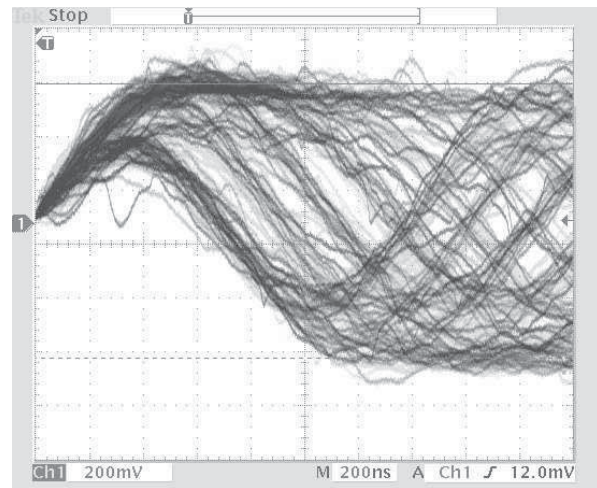

bad

If the oscilloscope shows a signal like the 'bad' one, and/or the amplitude decreases within 1 minute - the CD drive has to be replaced.

6

CD DRIVE – LASER CURRENT MEASUREMENT

The laser current can be measured as a voltage drop on a resistor. The resistor is marked in every Service Manual. The value depends on the type of CD drive.

	typical value	most probably defect
VAMxxxx	: 150-230mV	≥350mV
MCDxx	: 170-230mV	≥300mV
DA1x	: 210-250mV	≥350mV
DA2x	: 175-200mV	≥250mV

Use SBC444A (CD-DA) for measurement.

Laser power control

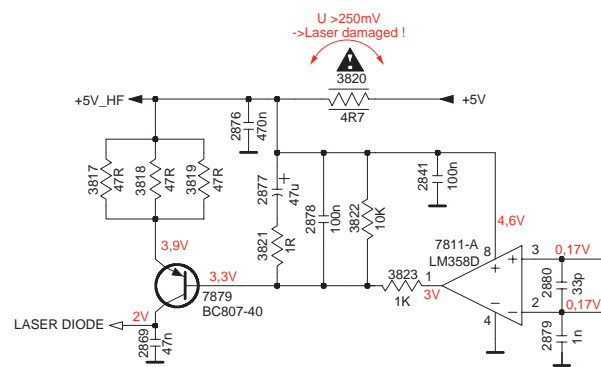

7

CD DRIVE – OFFSET MEASUREMENT

The photodiodes of the CD-drive may have an offset. These offsets have to be compensated by the signal processor. High offsets can lead to poor playability of some CDs (skipping tracks).

To measure the offset values, start the **Service Test Program** - section "Focus Test" without a CD.

The offsets can be measured with a DC Millivoltmeter directly on the connector (see drawing below). Pin numbering varies from drive to drive.

The values from diode A-D should read 0±10mV. Diodes E and F are less critical.

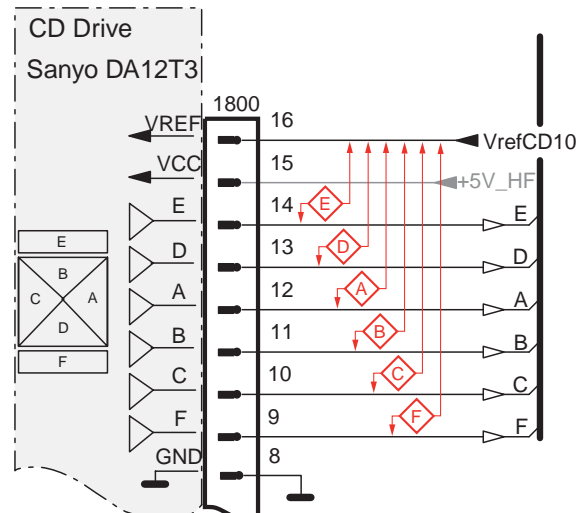

If one of the offsets is higher than ±10mV the CD drive has to be replaced. Otherwise replace the Signal Processor.

SET BLOCK DIAGRAM

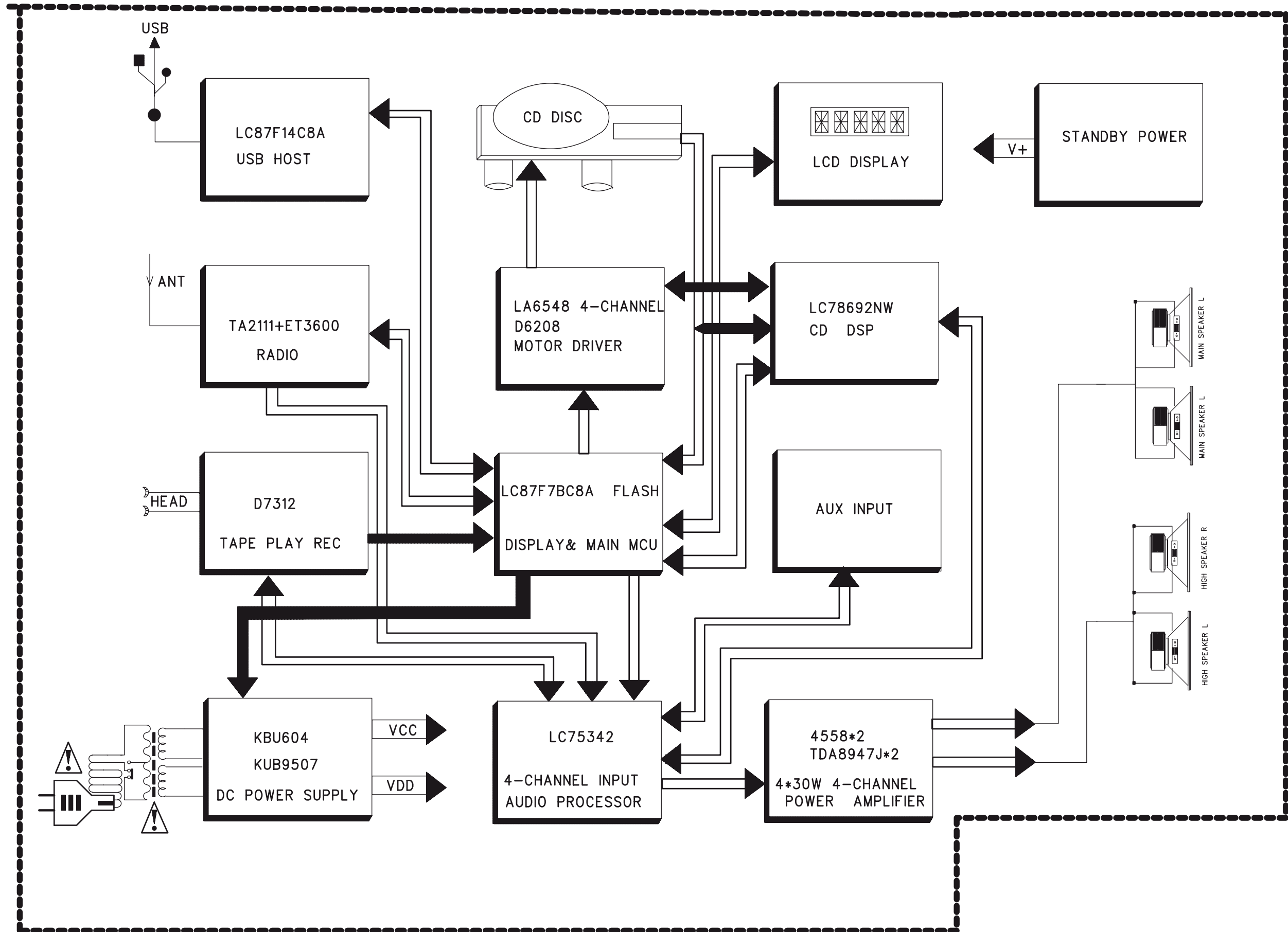

SET WIRING DIAGRAM

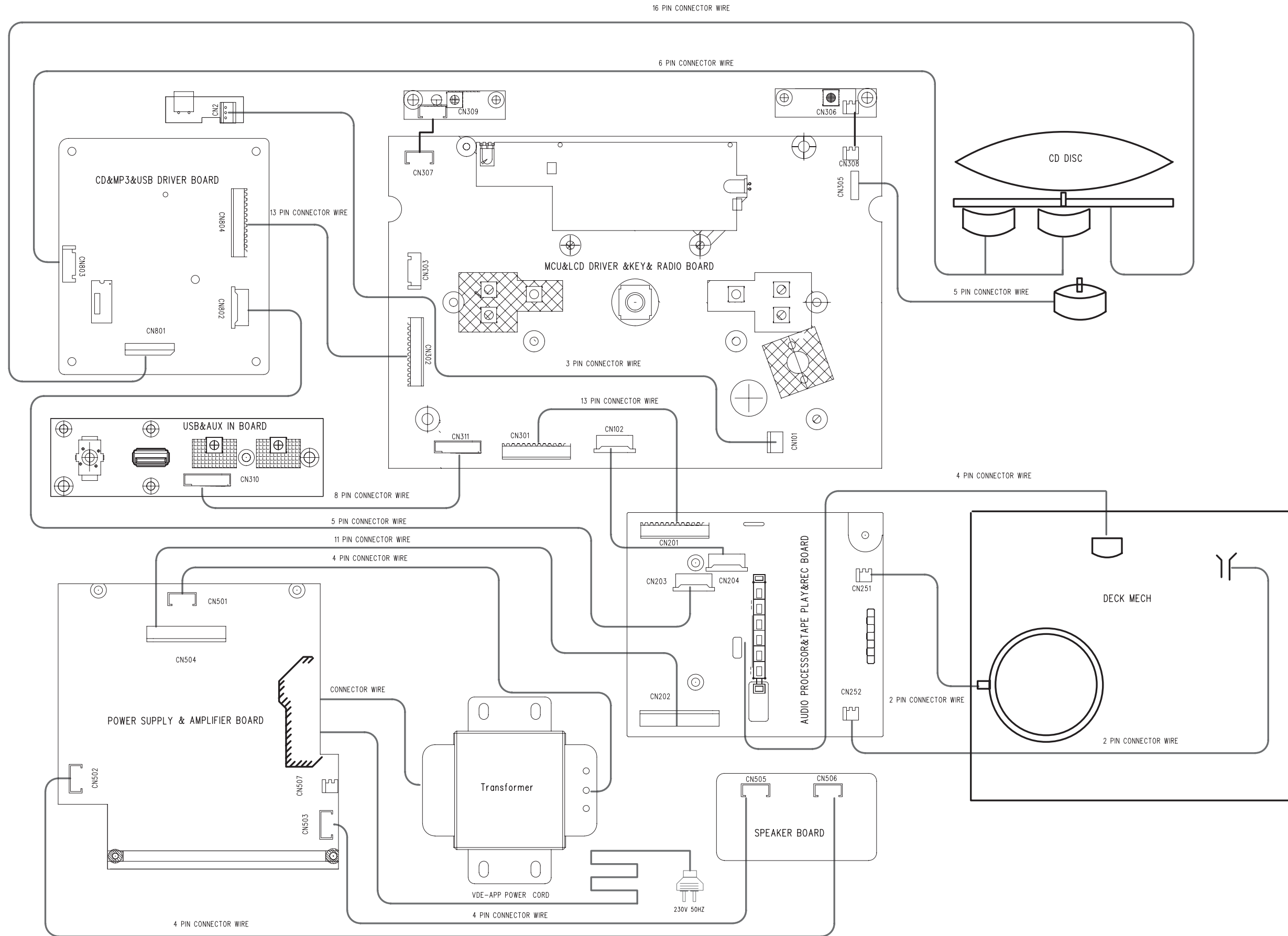

CIRCUIT DIAGRAM - CASSETTE BOARD

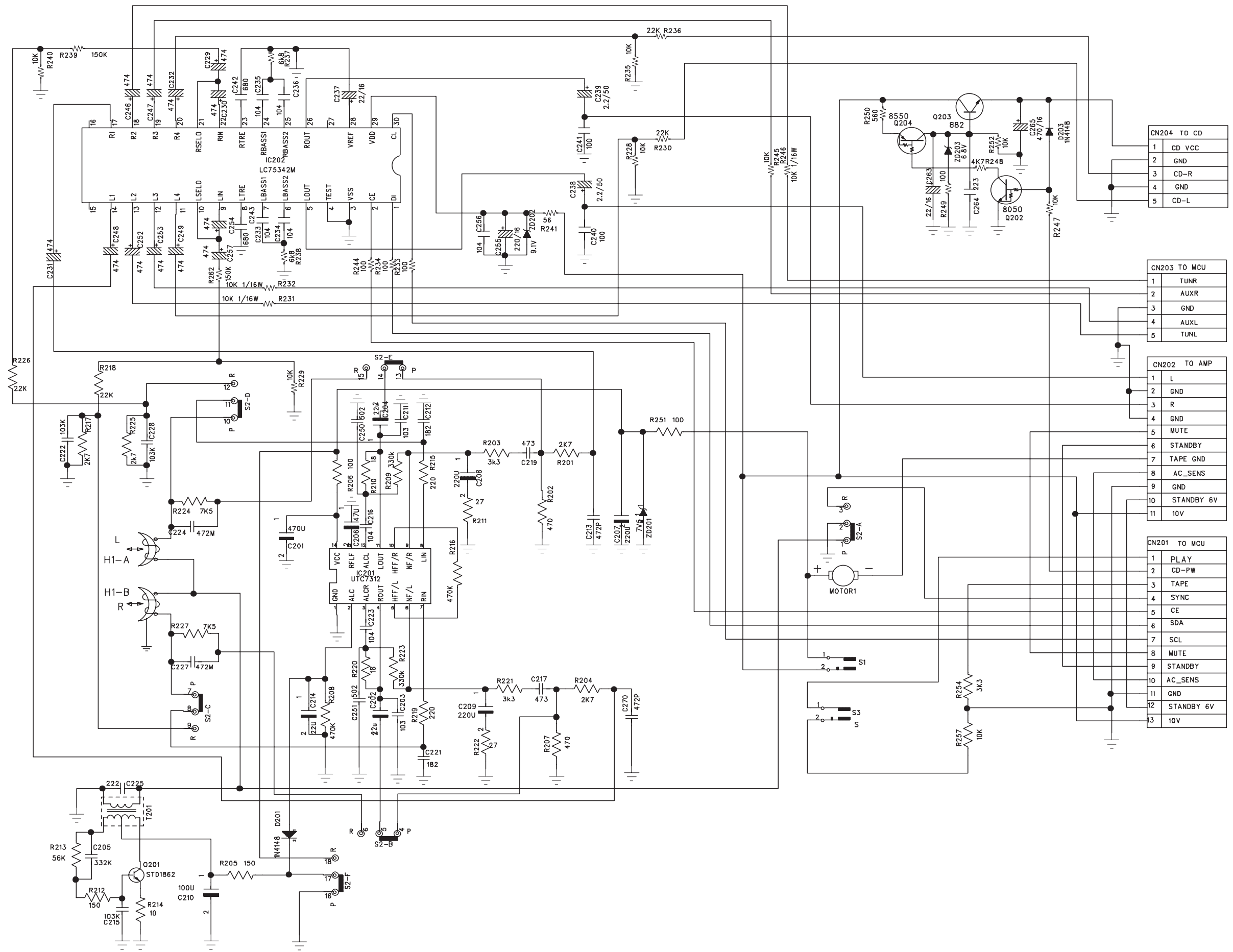

CN204 TO CD	
1	CD VCC
2	GND
3	CD-R
4	GND
5	CD-L

CN203 TO MCU	
1	TUNR
2	AUXR
3	GND
4	AUXL
5	TUNL

CN202 TO AMP	
1	L
2	GND
3	R
4	GND
5	MUTE
6	STANDBY
7	TAPE GND
8	AC_SENS
9	GND
10	STANDBY 6V
11	10V

CN201 TO MCU	
1	PLAY
2	CD-PW
3	TAPE
4	SYNC
5	CE
6	SDA
7	SCL
8	MUTE
9	STANDBY
10	AC_SENS
11	GND
12	STANDBY 6V
13	10V

PCB LAYOUT - MAIN(MCU) & USB BOARD

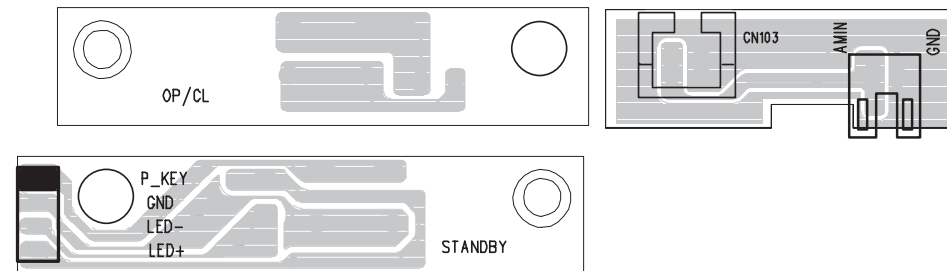
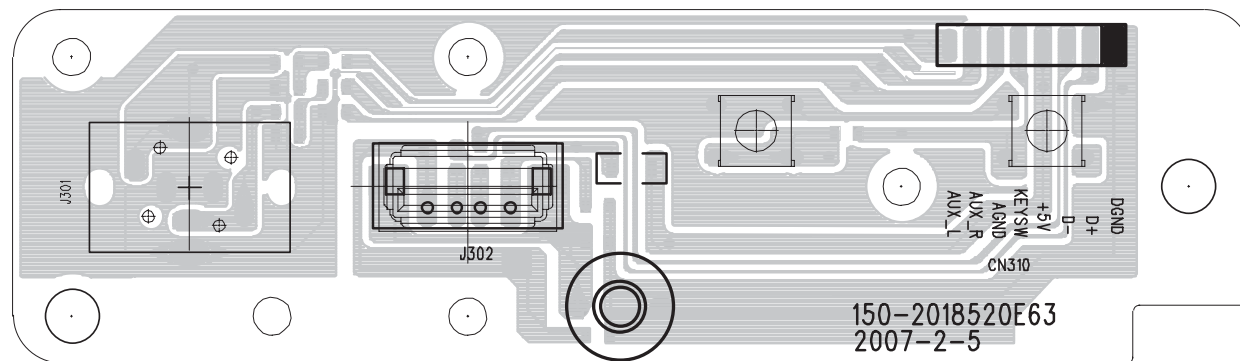
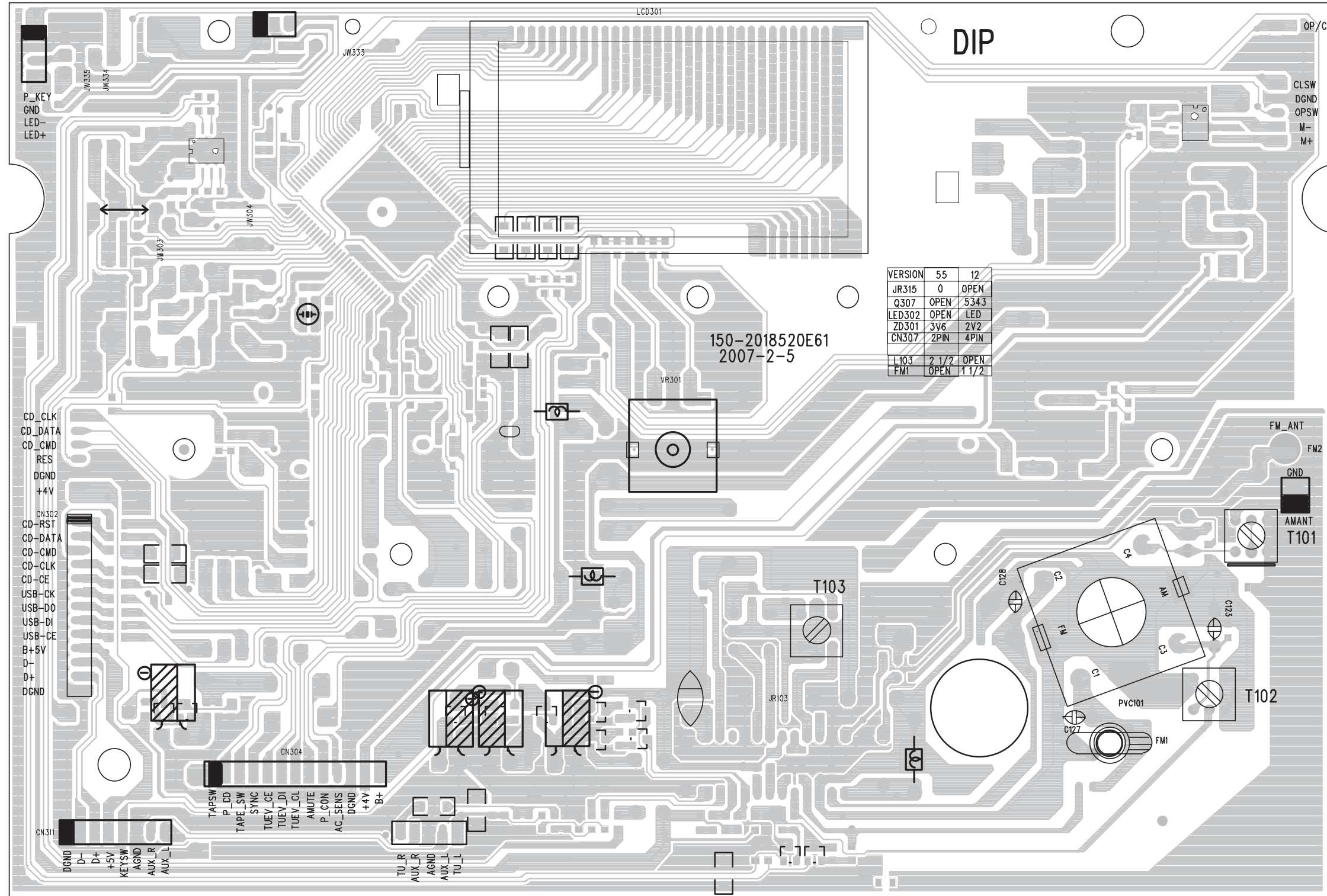

CIRCUIT DIAGRAM - MAIN(MCU) BOARD - TUNER PART

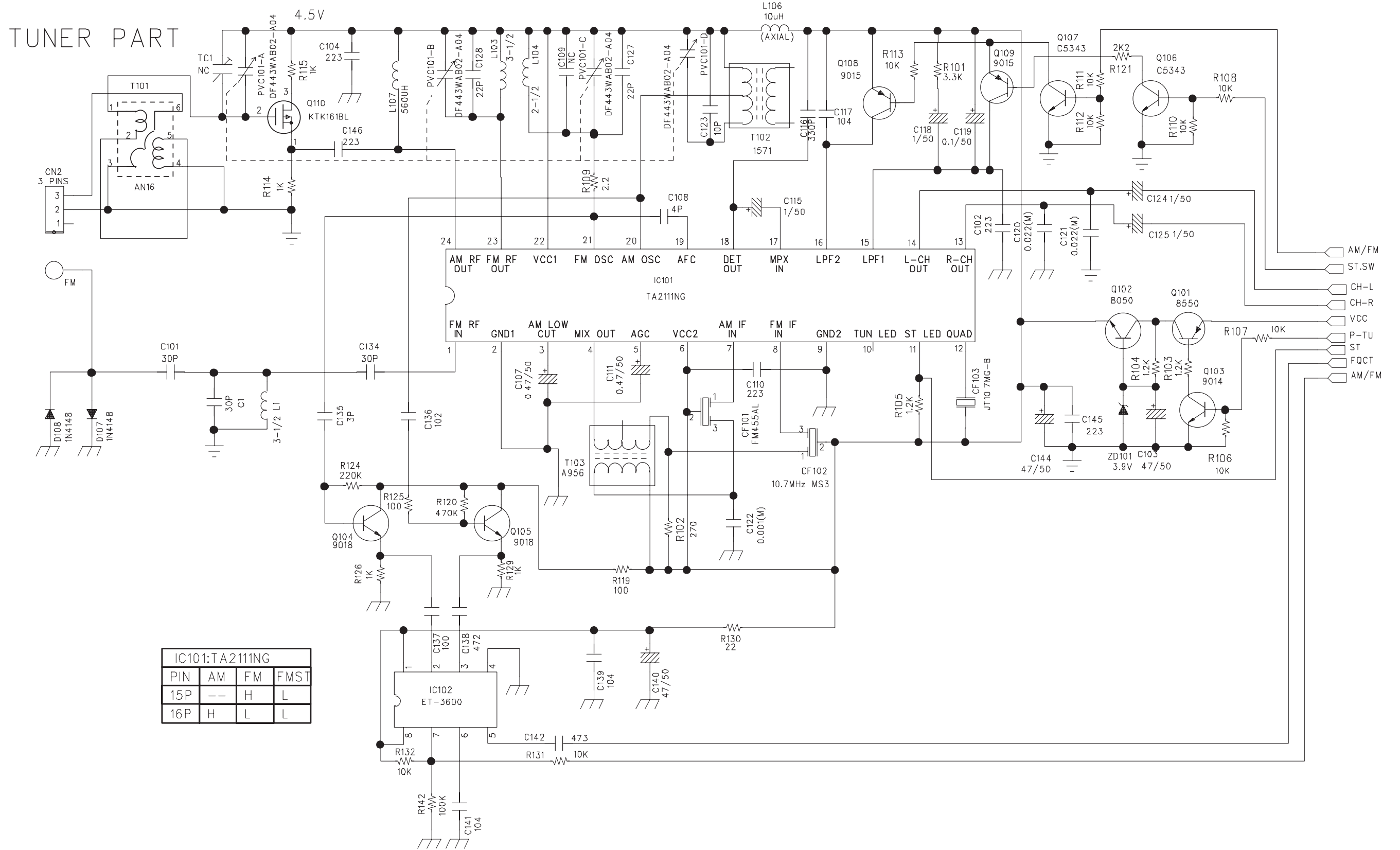

IC101:TA2111NG			
PIN	AM	FM	FMST
15P	--	H	L
16P	H	L	L

CIRCUIT DIAGRAM - MAIN(MCU) & USB BOARD

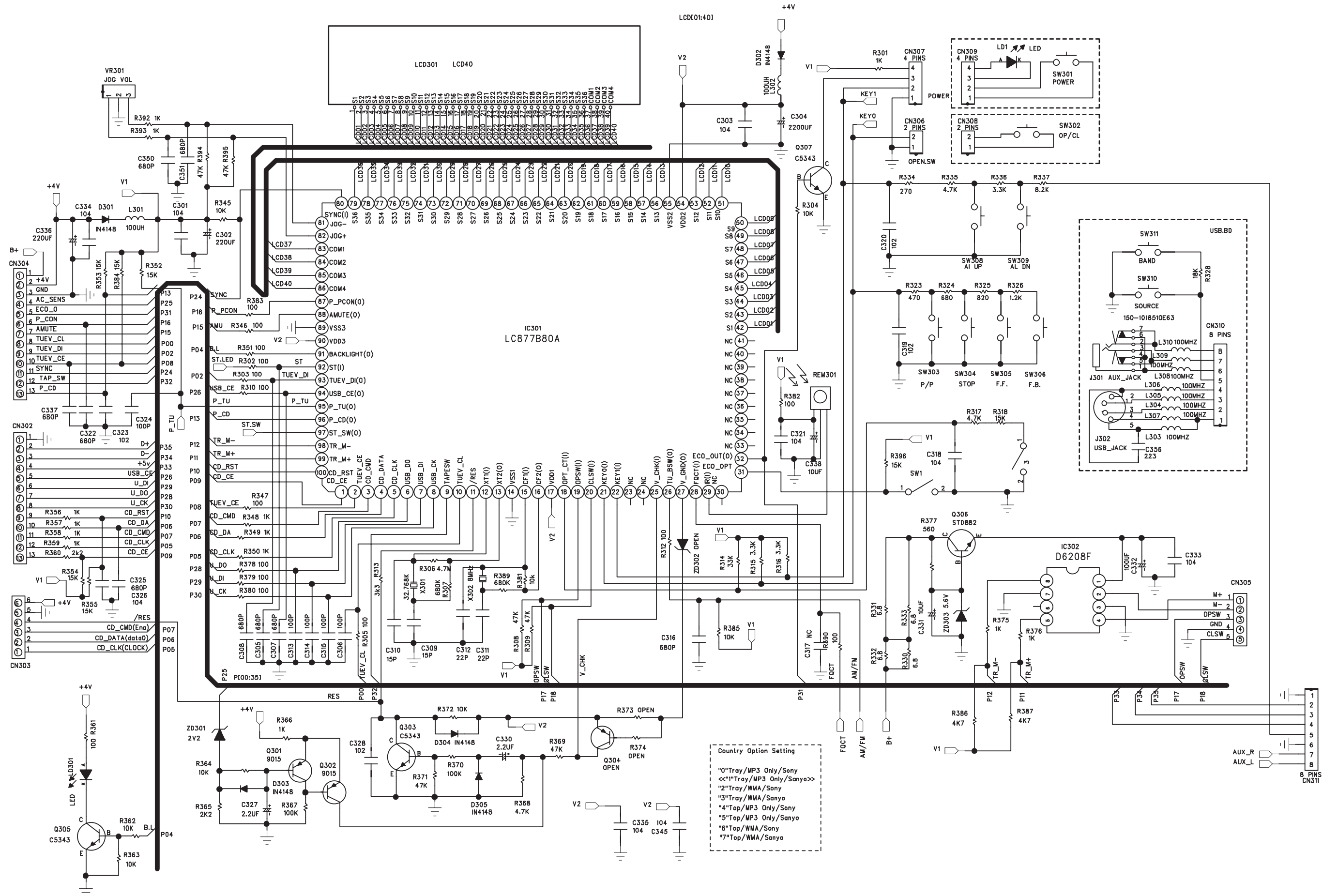

PCB LAYOUT - CD BOARD

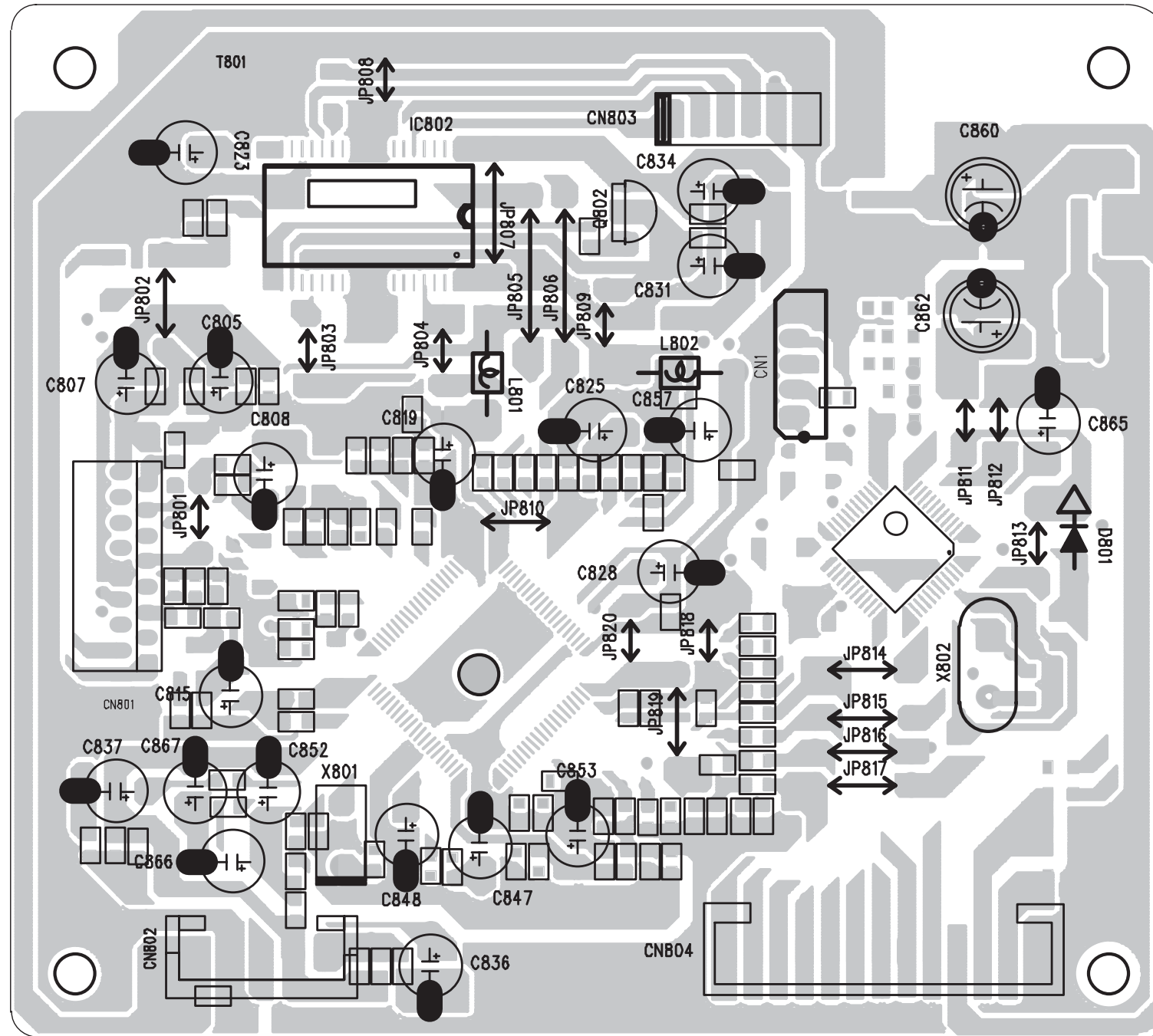

CIRCUIT DIAGRAM - CD BOARD

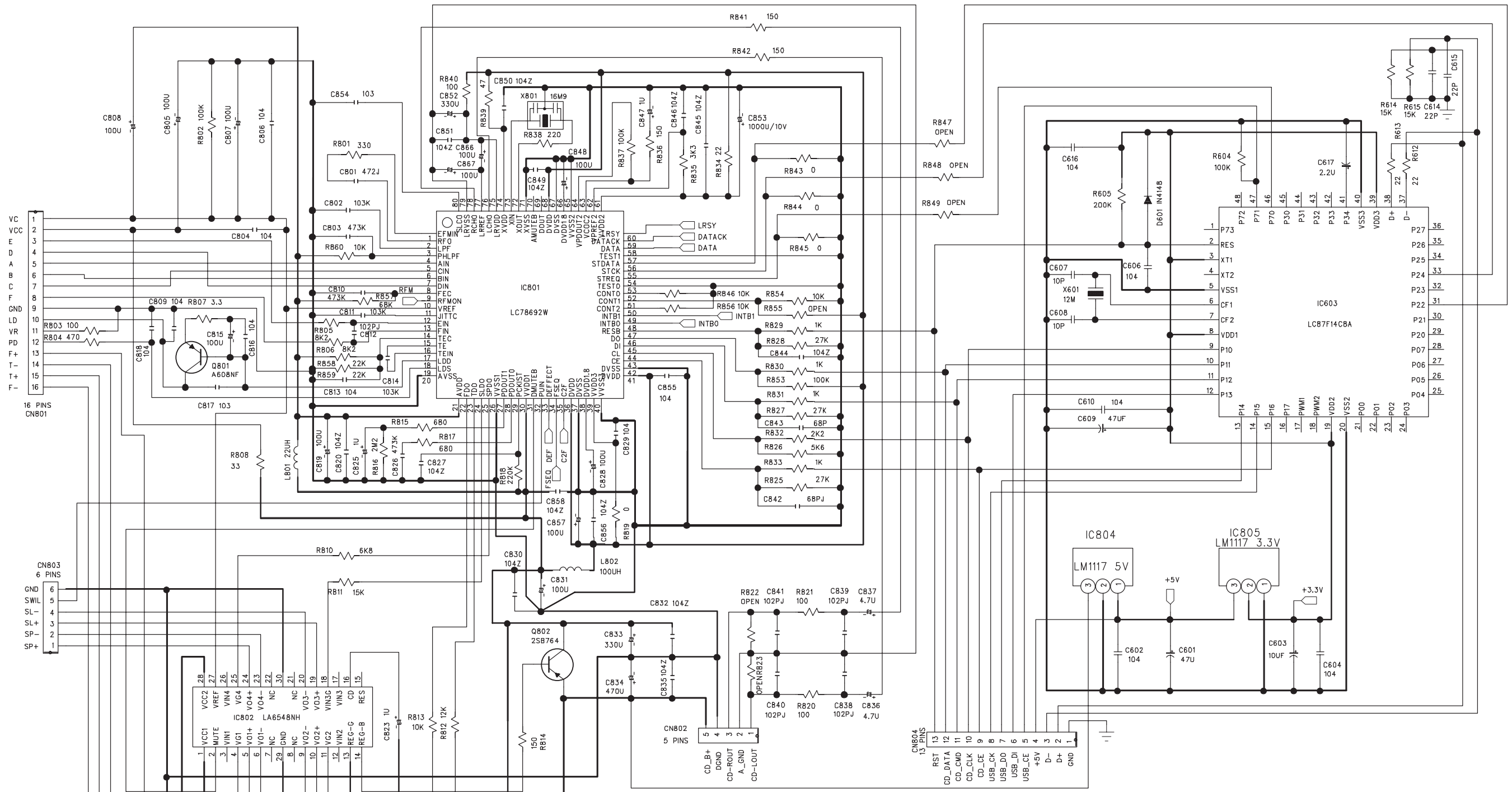

NO:	NO USB	USB	Magnet	Ball
R843	0	5K6		
R844	0	5K6		
R845	0	OPEN		
R847	OPEN	3K3		
R848	OPEN	3K3		
R849	OPEN	3K3		
R850	OPEN	OPEN		
R854			10K	OPEN
R855			OPEN	10K

PCB LAYOUT - AMP BOARD FOR VERSION /55/77/79

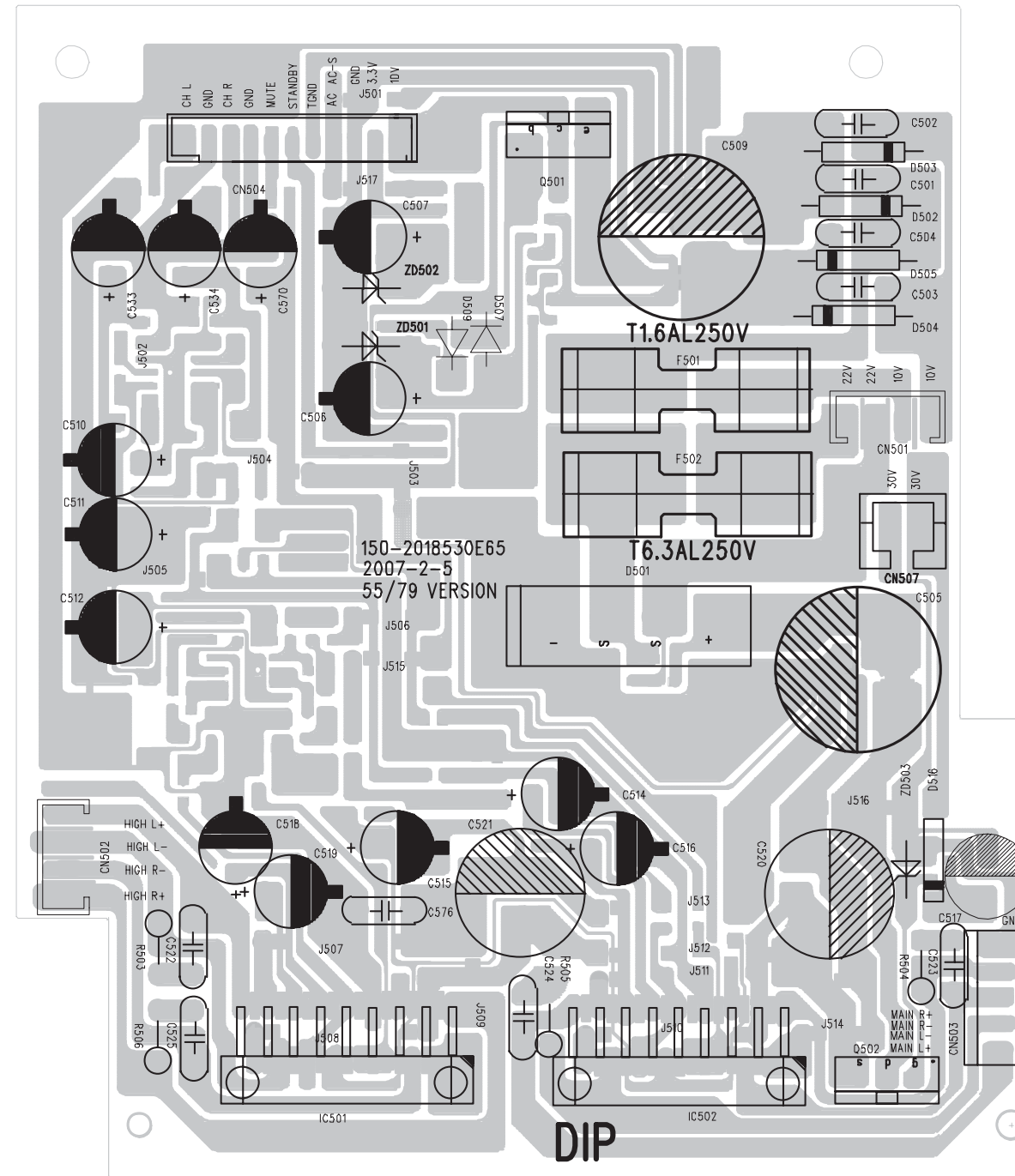

PCB LAYOUT - AMP BOARD FOR VERSION /12/05
TOP VIEW

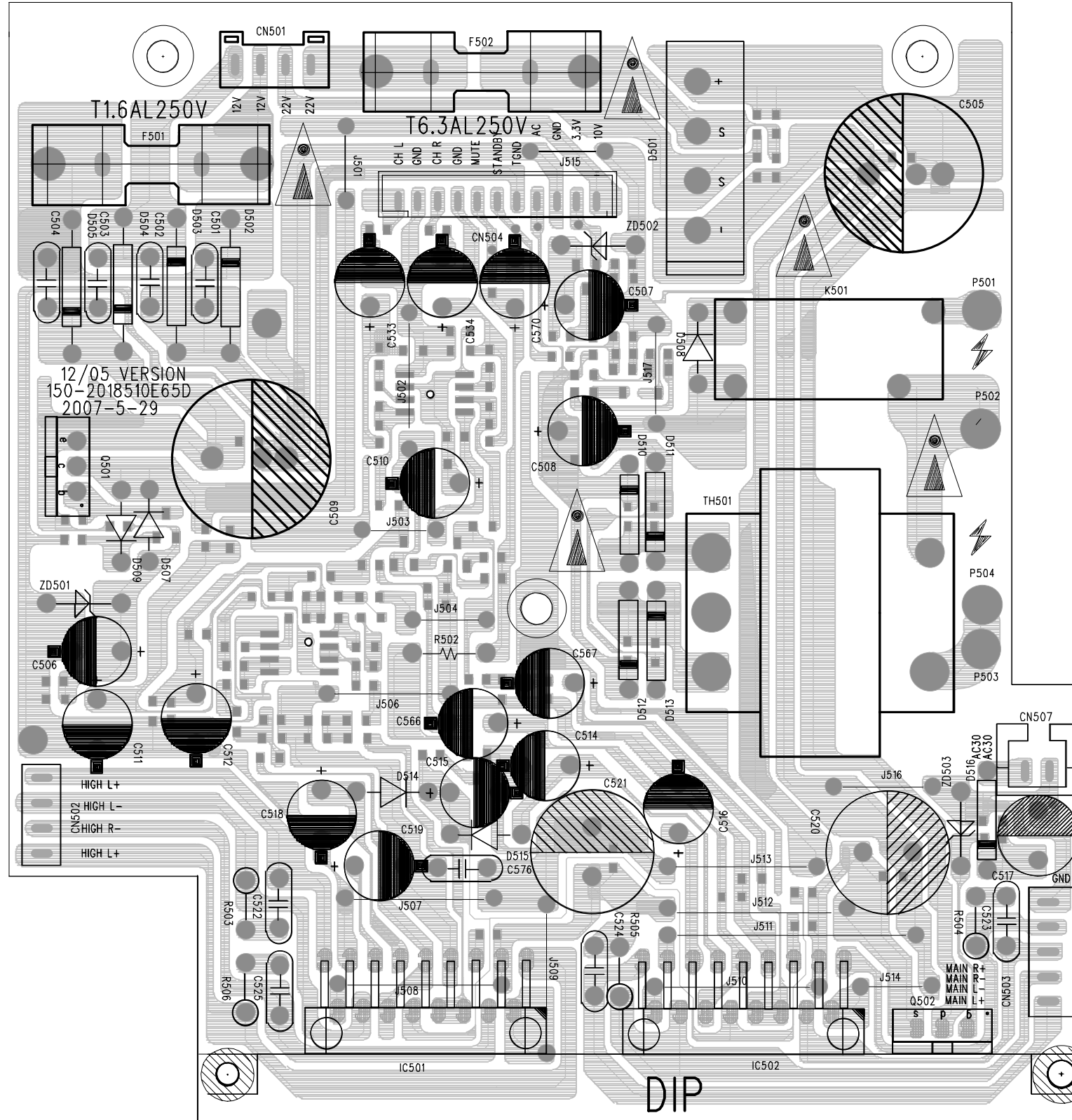

PCB LAYOUT - AMP BOARD FOR VERSION /12/05
BOTTOM VIEW

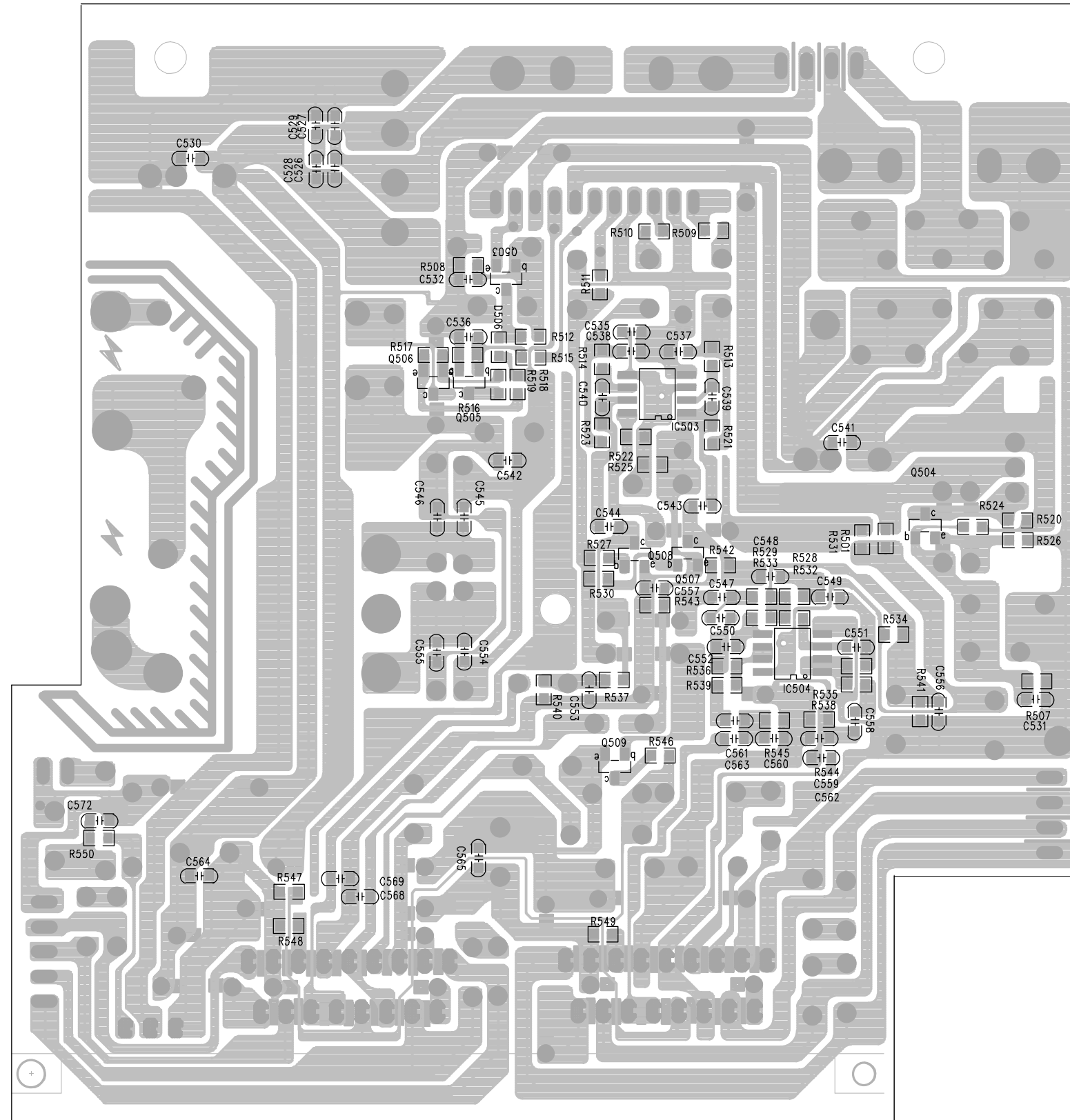

CIRCUIT DIAGRAM - AMP BOARD FOR VERSION /55/77/79/98

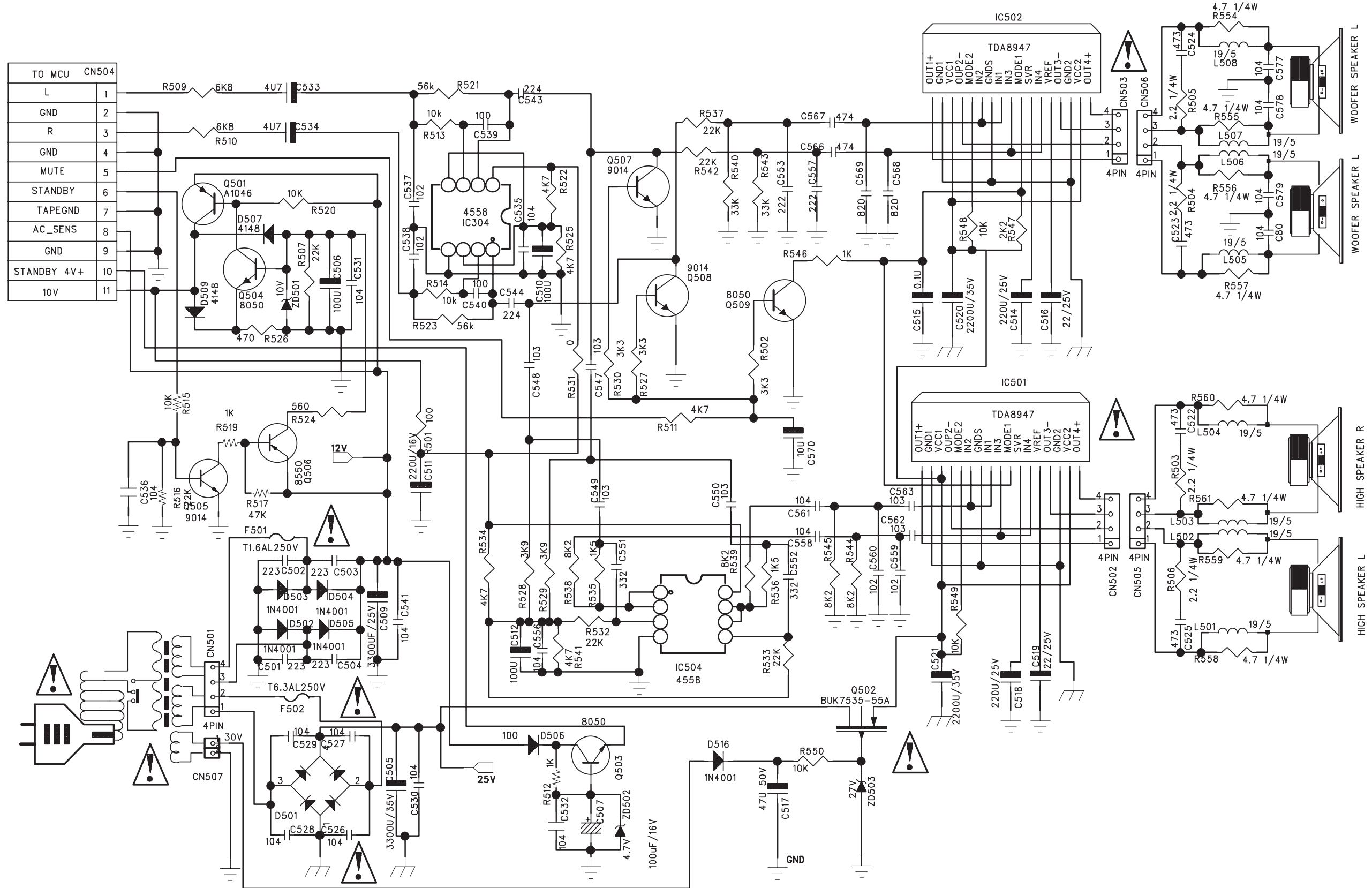

CIRCUIT DIAGRAM - AMP BOARD FOR VERSION /12/05

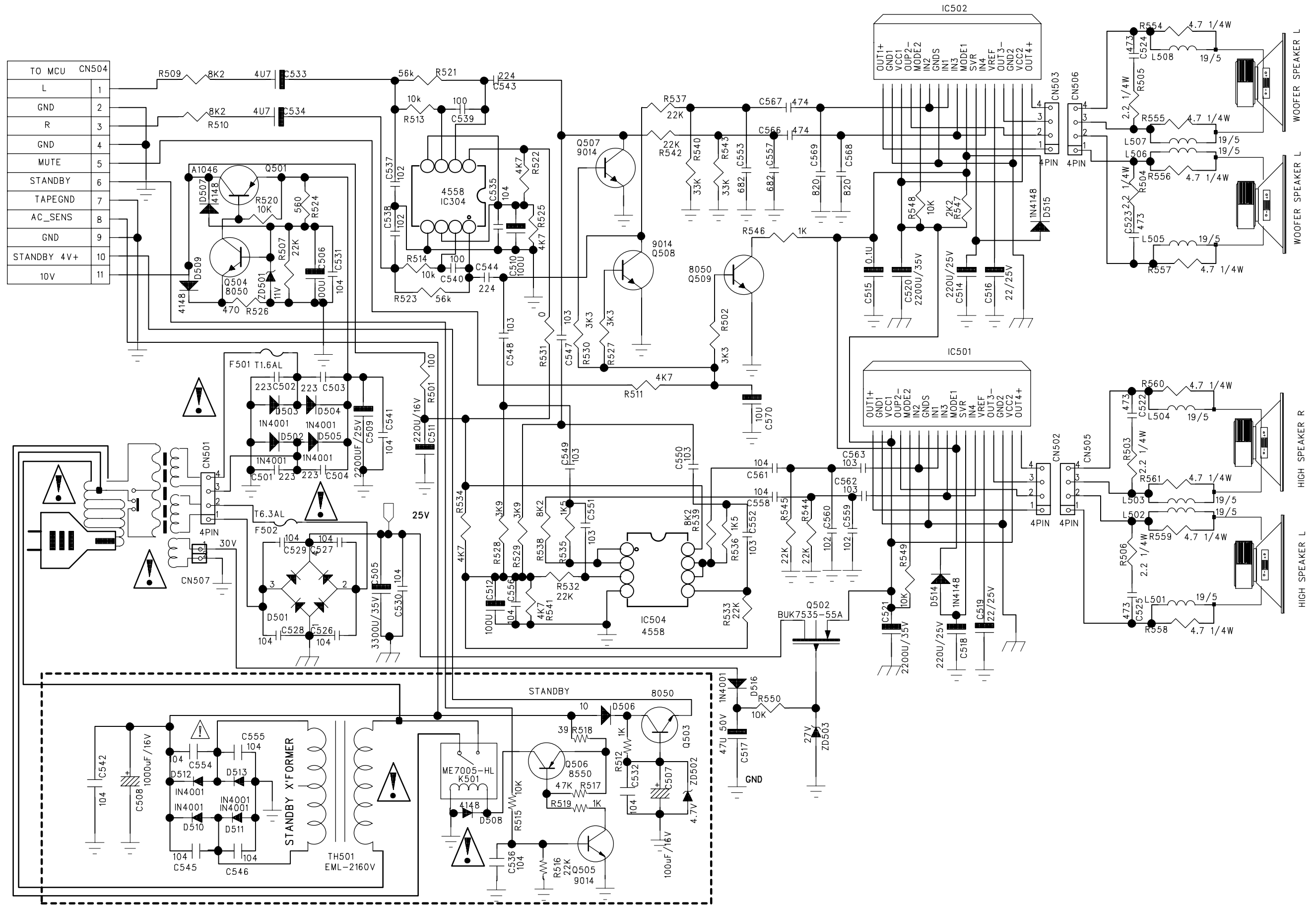

SET MECHANICAL EXPLODED VIEW

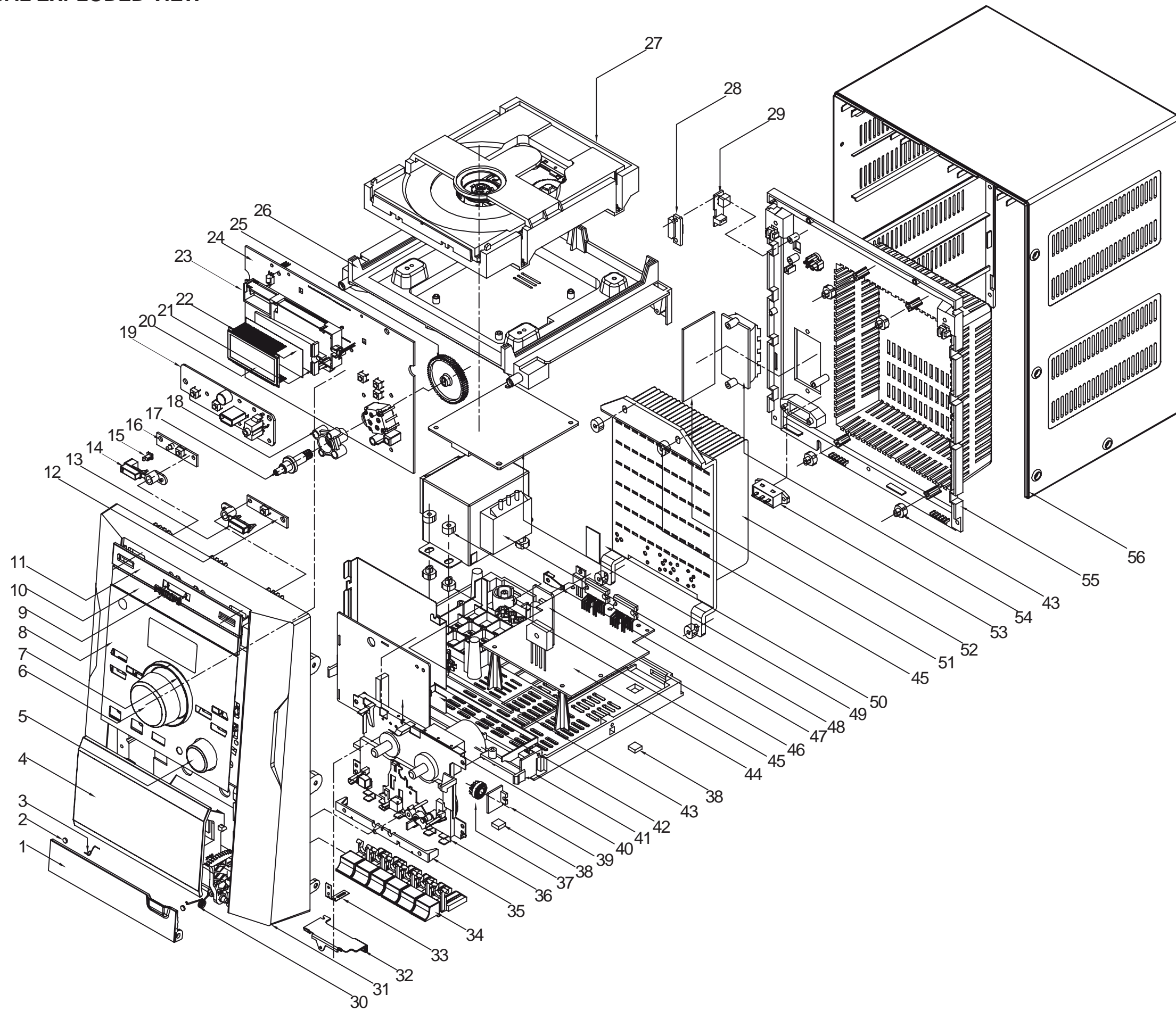

MECHANICAL & ACCESSORIES PARTS LIST

1	996510002247	CASS KEY DOOR	56	996510002240	TOP COVER
1	996510004643	CASS KEY DOOR /77/79/98	A	994000004736	SLIDE SWITCH (SSV-12-8700S)
2	996510002263	CASSETTE KEYS DOOR FOOT	B	996500038819	CD MECHANISM SANYO DA11VF
3	996510002265	CASS KEYS DOOR SPRING	C	996510002243	REMOTE RECEIVER LENS
4	996510002246	CASS DOOR	D	996510004639	FWM185 SPEAKER 8R 30W RIGHT
4	996510004642	CASS DOOR /77/79/98	E	996510006807	SPEAKER (8R 30W) -L /98
5	996510002255	TUNING KNOB	F	996510004640	SPEAKER BOX ASS'Y 8R 30W -L
6	996510002254	VOLUME KNOB CHROME	G	996510002238	SPEAKER BOX ASS'Y 8R 30W
7	996510002248	VOLUME RING SPRAY SIL	H	△ 996510004702	APP AC CORD SET W/K-1004 /77
8	996510002244	FRONT LENS	I	△ 996510002304	AC CORD 1650mm /12/55/98
10	996510002245	CD DOOR	J	△ 996510002409	BS APP AC CORD SET /05
10	996510004641	FWM185 CD DOOR /77/79/98	K	△ 996510004651	SAA APP AC CORD L1700mm /79
13	996510002258	OPEN/CLOSE KNOB	L	996510002306	REMOTE HANDSET
14	996510002257	STANDBY KNOB	M	996510006810	AM LOOP ANTENNA
14	996510004644	STANDBY KNOB /77/79/98			
15	996510002260	STANDBY LIGHT GUIDE BKT			
17	996510002261	TUNING SHAFT			
18	996510002259	TUNING SHAFT BRACKET			
25	996510002277	TUNING GEAR			
26	996510002307	LOADER BRACKET			
27	996500038820	CD LOADER WXD-8210 (COMPLETED)			
28	996510002242	LOOP ANT COVER			
30	996510002266	CASSETTE DOOR SPRING			
31	996510002239	FRONT CAB			
32	996510002267	CASS BRACKET			
34	996510002249	STOP KNOB			
34	996510002250	PLAY KNOB			
34	996510002251	REC KNOB			
34	996510002252	F.FWD KNOB			
34	996510002253	REW KNOB			
34	996510002256	PAUSE KNOB			
35	994000004719	CASS HOLDER			
36	994000004734	CASS DECK CS-21SC-820T			
37	994000004726	DAMPER GEAR (MODE:0.8)			
38	996510002262	PU RUBBER FOOT			
39	994000004727	GEAR STAND (MODE:0.8)			
40	996510002269	CASSETTE BOARD			
41	996510002305	BASE CABINET			
42	996510002268	SCREEN COVER			
48	△ 996510002303	TRANSFORM VDE-STD 230V /05/12			
48	△ 996510002421	TRANSFORMER,VDE-STD,EI-66 /55/77/98			
48	△ 996510004650	TRANSFORMER EML-2183ST /79			
55	996510002241	REAR CAB /05/12/77			
55	996510002420	REAR CAB /55			
55	996510006808	REAR CAB /98			

Note: Only these parts mentioned in the list are normal service parts.

ELECTRICAL PARTSLIST**CASSETTE BOARD**

IC201	994000004007	IC D7312
IC202	996500038832	IC LC75342-TLM-E
Q201	994000004004	CHIP TR NPN 8050C
Q202	994000004004	CHIP TR NPN 8050C
Q203	996510002270	TR NPN UTC 2SD882 (TO-126)
Q204	994000004005	CHIP TR PNP 8550D
SW201	994000004784	REC/PLAY SW (PS-62D01-NS)
T201	994000004008	IFT BRO 10MM

USB BOARD

J301	996510002273	ST PHONES JACK 3.5mm TC38
J302	996510002272	USB A TYPE (FEMALE) S/T
L303A	996510002271	COIL 39mH CW68-393K
SW310	994000004792	TACT SW 6X6MM H4.3
SW311	994000004792	TACT SW 6X6MM H4.3

MCU BOARD

CF101	996500038852	FILTER FM450AL (DOUBLE)
CF102	994000005186	FILTER 10.7MC (L10.7A)
CF103	994000005187	DISCRIMINATOR J10.7C
F501	△ 994000004782	FUSE 50T D5X20 1.6A 250V(S.B.)
F502	△ 996510002287	FUSE T6.3A 250V 5x20
FM1	996510002282	COIL 1T5 D7.6 #0.7 CW
IC101	994000003962	IC TA2111NG
IC102	996500038835	IC ET3600 SOP8
IC301	996510002284	IC LC87F7BC8A(MCU\QIP100E\OTP)
IC302	994000004737	IC D6208 (MOTOR DRIVER)
L101	996510002281	COIL 3T5 D4.8 #0.8 CW
L102	996510002281	COIL 3T5 D4.8 #0.8 CW
LCD301	996510002276	LCD MODULE SDH-DA1455-TN-4
LE302	996510002283	LED RED DL23RTH /L2R3A4HD00
LED301	996510002275	LED WHITE D5mm (DL5NWCH)

Q101	994000004005	CHIP TR PNP 8550D
Q102	994000004004	CHIP TR NPN 8050C
Q103	994000003972	CHIP TR MMBT9014C
Q104	994000004743	CHIP TR MMBT9018H
Q105	994000004743	CHIP TR MMBT9018H
Q106	994000003972	CHIP TR MMBT9014C
Q107	994000003972	CHIP TR MMBT9014C
Q108	994000003973	CHIP TR MMBT9015C
Q109	994000003973	CHIP TR MMBT9015C
Q110	996510002286	NFET KTK161BL
Q301	994000003973	CHIP TR MMBT9015C
Q302	994000003973	CHIP TR MMBT9015C
Q303	996500038838	TR NPN 2SC5343YPF (TO-92)

MCU BOARD

Q305	996500038838	TR NPN 2SC5343YPF (TO-92)
Q306	996510002285	TR NPN STD882 (TO-92)(TP)
Q307	996500038838	TR NPN 2SC5343YPF (TO-92)
REM301	996510002274	SENSOR AT136BV3 36KHz 3.3V
SW301	994000004792	TACT SW 6X6MM H4.3
SW302	994000004792	TACT SW 6X6MM H4.3
SW303	994000004792	TACT SW 6X6MM H4.3
SW304	994000004792	TACT SW 6X6MM H4.3
SW305	994000004792	TACT SW 6X6MM H4.3
SW306	994000004792	TACT SW 6X6MM H4.3
SW308	994000004792	TACT SW 6X6MM H4.3
SW309	994000004792	TACT SW 6X6MM H4.3
T101	996510002279	AM IFT BLACK AN16 7mm
T102	996510002280	AM IFT RED 7mm (1571)
T103	994000003964	AM IFT YEL 7MM A956
VR301	996510002278	ENCODER
X301	996500038822	CRYSTAL JF32.768kHz JU2x6
X302	996500038823	CRYSTAL 8MHZ(HC-49US)

CD BOARD

IC801	996510002298	IC LC78692W (CD DSP) SQFP80
IC802	996500038842	IC LA6548NH (4 CH DRIVER)
IC803	996510002301	IC LC87F14C8AU-TQFP-E
IC804	996510002299	IC LM1117 5V (SOT-223)
IC805	996510002300	IC LM1117S-3.3V (SOT-223)
Q801	994000003973	CHIP TR MMBT9015C
Q802	996500038840	TR PNP 2SB764E-SSH-AE(TP)
X801	996510002297	C RESON'R QZTT16.93MX 3P

AMP & SPEAKER BOARD

C505	996510002291	E CAP 35V +-20% 3300uF
C509	996510002290	E CAP 25V +-20% 4700uF
D501	996500038843	BRIDGE RECTIFIER KBU604 6A
IC501	996510002288	IC TDA8947J (DBS17P)(SOT243-1)
IC502	996510002288	IC TDA8947J (DBS17P)(SOT243-1)
IC503	996510002294	IC D4558 (SOP8)
IC504	996510002294	IC D4558 (SOP8)
K501	△ 996510002293	RELAY:DC5V (ME-7,005-HL)
Q501	△ 994000004064	POWER TR PNP KTA1046/P
Q502	996510002289	NFET BUK7535-55A
Q503	994000004004	CHIP TR NPN 8050C
Q504	994000004004	CHIP TR NPN 8050C
Q505	994000003972	CHIP TR MMBT9014C

ELECTRICAL PARTSLIST**AMP & SPEAKER BOARD**

Q506	994000004005	CHIP TR PNP 8550D
Q507	994000003972	CHIP TR MMBT9014C
Q508	994000003972	CHIP TR MMBT9014C
Q509	994000004004	CHIP TR NPN 8050C
SP501	996510002296	SPEAKER TERMINAL 8POSITION
TH501	△ 996510002292	TRANSFORMER VDE-APP 230V

Note: Only these parts mentioned in the list are normal service parts.

REVISION LIST

1.0 Manual 3141 785 31680

Initial Service Manual released.

1.1 Manual 3141 785 31681

In this version,

- 1) the instruction of CD playability check is added.
- 2) Chapter 7 have been revised ---- add Schematics and PCB Layouts for version /05/12.
- 3) Version /77 & /79 have been added.
Chapter 8 Mechanical Parts List updated.

1.1 Manual 3141 785 31682

In this version,

- 1) Version /98 has been added.
Chapter 8-2 Mechanical & Accessories Parts List updated.