

In this chapter the following paragraphs are included:

- 5.1 Test points
- 5.2 Service Modes and Dealer Service Tool (DST)
- 5.3 Error code buffer and error codes
- 5.4 The "blinking LED" procedure
- 5.5 Trouble shooting tips
- 5.6 Customer service mode

Test points

The A8 chassis is equipped with test points in the service printing. These test points are referring to the functional blocks:

- A1-A2-A3, etc.: Test points for the audio processing circuitry
- C1-C2-C3, etc.: Test points for the control circuitry
- F1-F2-F3, etc.: Test points for the frame drive and frame output circuitry
- I1-I2-I3, etc.: Test points for the intermediate frequency circuitry
- L1-L2-L3, etc.: Test points for the line drive and line output circuitry
- P1-P2-P3, etc.: Test points for the power supply
- T1-T2-T3, etc.: Test points for the teletext circuitry
- V1-V2-V3, etc.: Test points for the video processing circuitry

Measurements are performed under the following conditions:

Video: colour bar signal; audio: 3KHz left, 1KHz right

Service modes and Dealer Service Tool (DST)

For easy installation and diagnosis the dealer service tool (DST) RC7150 can be used. When there is no picture (to access the error code buffer via the OSD), DST can enable the functionality of displaying the contents of the entire error code buffer via the blinking LED procedure. The ordering number of the DST (RC7150) is 4822 218 21232.

1 Installation features for the dealer

The dealer can use the RC7150 for programming the TV-set with presets. 10 Different program tables can be programmed into the DST via a GFL TV-set (downloading from the GFL to the DST; see GFL service manuals) or by the DST-I (DST interface; ordering code 4822 218 21277). For explanation of the installation features of the DST, the directions for use of the DST are recommended (For the A8 chassis, download code 4 should be used).

2 Diagnose features for the servicer

A8 sets can be put in the two service modes via the RC7150. These are the Service Default Mode (SDM) and the Service Alignment Mode (SAM). SDM can also be entered by short circuiting the jumpers 9040 and 9041 on the chassis with a screwdriver.

Service Default Mode (SDM)

The purpose of the SDM is:

- provide a situation with predefined settings to get the same measurements as in this manual
- start the blinking LED procedure
- have to possibility to override the 5V protection

Entering the SDM:

- By transmitting the "DEFAULT" command with the RC7150 Dealer Service Tool (this works both while the set is in normal operation mode or in the SAM)
- By shorting jumpers 9040 and 9041 on the monocarrier with a screwdriver while switching on the set

By temporarily shorting jumper 9040 and 9041 when switching the set on, the 5V protection is disabled.

CAUTION ! Overriding the 5V protection should only be used for a short period of time

Blinking LED procedure

When an error code is present in the error buffer, the LED will blink the number of times, equal to the value of the most current error code. For recognition of the SDM, "SDM" is displayed at the upper right side of the screen.

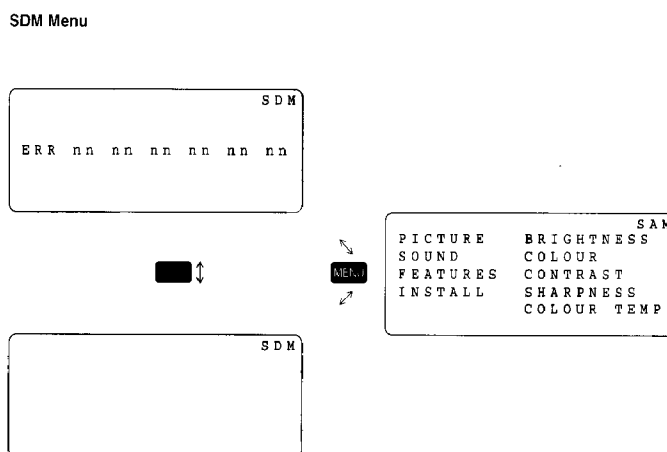

Figure 5-1 Service Default Mode screen

Exit the SDM: Switch the set to Standby (the error buffer is also cleared)

Note: When the mains power is switched off while the set is in SDM, the set will switch to SDM immediately when the mains is switched on again.

The SDM sets the following pre-defined conditions:

- Pal/Secam sets: tuning at 475.25 PAL
- NTSC sets: tuning at channel 3 (61.25MHz)

Volume level is set to 25% (of the maximum volume level). Other picture and sound settings are set to 50%. The following functions are switched off in SDM (and after leaving SDM):

- Timer
- Sleep timer

The following functions are disabled during SDM (and enabled after leaving SDM)

- Parental lock
- Hospitality Mode
- No-ident Timer (normally the set is automatically switched off when no video signal (IDENT) was received for 15 minutes).

All other controls operate normally.

Special functions in SDM

ACCES TO NORMAL USER MENU

Pressing the "MENU" button on the remote control switches between the SDM and the normal user menus (with the SDM mode still active in the background)

CHANNEL SEARCH

Pressing the "P+" button of the remote control starts a tuning search. Search is indicated by a blinking led (this stops when a transmitter is found; the transmitter is stored on the highest channel number, typically this is 99 and the tv switches to this preset)

ERROR BUFFER

Pressing the "OSD" button of the remote control shows/hides the error buffer. OSD can be hidden to prevent interference with oscillogram measurements.

ACCES TO SAM

By pressing the "VOLUME +" and "VOLUME -" buttons on the local keyboard simultaneously the set switches from SDM to SAM.

Service Alignment Mode (SAM)

The purpose of the SAM is to do alignments, option settings, display/clear the error code buffer and reload default values.

ENTERING SAM:

- By transmitting the "ALIGN" command with the RC7150 Dealer Service Tool (this works both while the set is in normal operation mode or in the SDM)
- By pressing the "VOLUME +" and "VOLUME -" key on the local keyboard simultaneously when the set is in SDM

EXIT SAM:

Switch the set to Standby (the error buffer will be erased)

Note: When the mains power is switched off while the set is in SAM, the set will enter to SDM immediately when the mains is switched on again.

SAM Menu

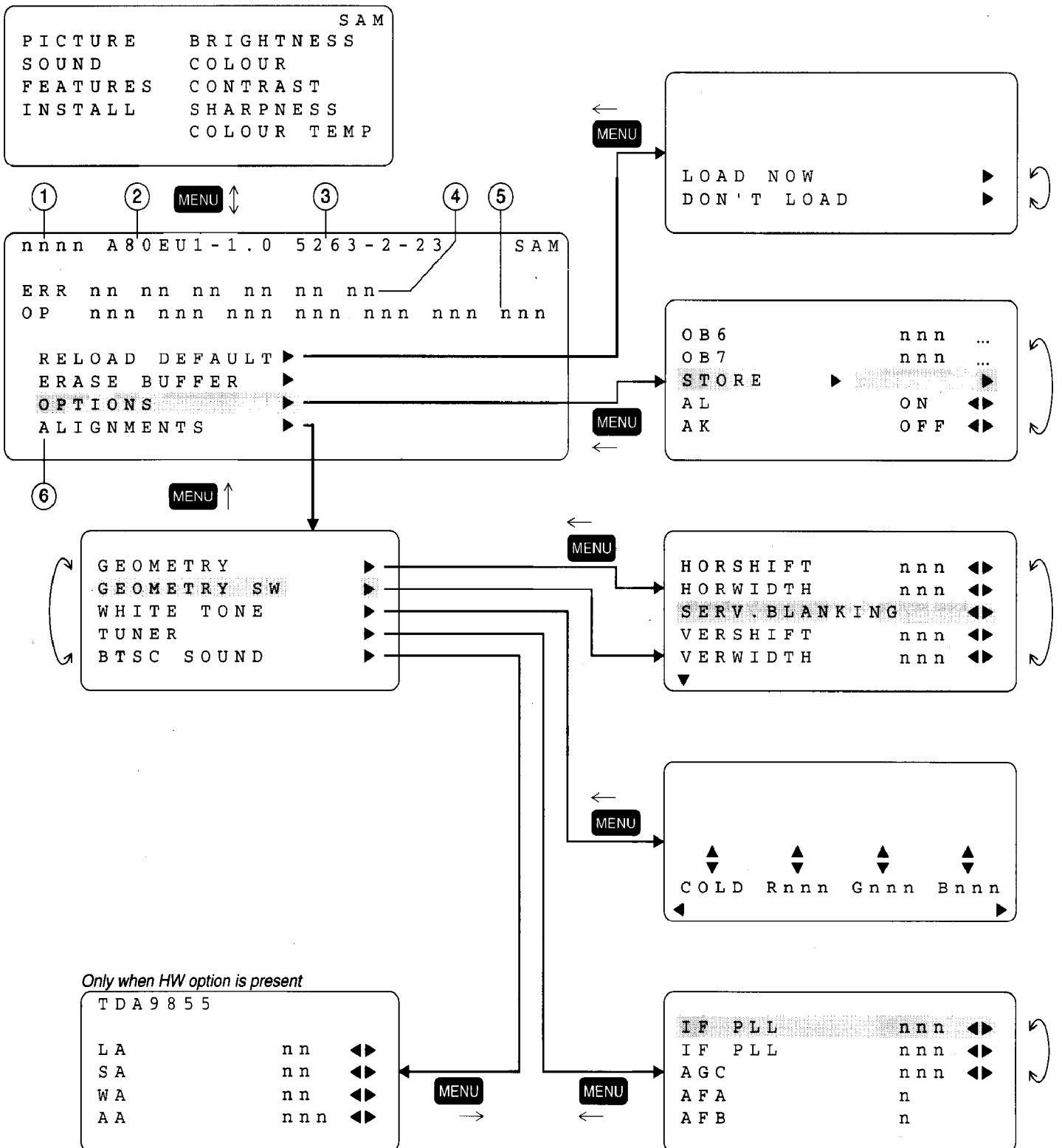

CL 86532036_001.ai
260598

Figure 5-2 Service Alignment Mode screens and structure

Explanation notes/references:

(1) Operation hours timer (hexadecimal)

(2) Software identification of the main micro controller (A80BBC-X.Y)

- A80 is the chassis name for A8.0A
- BBC is 2 letter and 1 digit combination to indicate the software type and the supported languages:
 - PN1:Pal/Multi; NO teletext; English, Malay and Chinese
 - PN2:Pal/Multi; NO teletext; English and Hindi
 - PN3:Pal/Multi; NO teletext; English and Arabic
 - PT1:Pal/Multi WITH teletext; English, Malay and Chinese
 - NG1:NTSC; 2CS sound; English and Korean
 - NB1:NTSC; BTSC sound; English and Taiwanese
- X = (main version number)
- Y = (subversion number)

(3) Software identification of a separate Teletext micro controller (DDDD E FF) (not applicable for A8.0A)

(4) Error buffer (6 errors possible)

(5) Option bytes (7 codes possible), summary of options are explained below

(6) Sub menus are listed in a scroll-menu.

SAM MENU CONTROL

Menu items can be selected with the cursor UP/DOWN key. The selected item will be highlighted. When not all menu items fit on the screen, moving the cursor UP/DOWN will display the next/previous menu items.

With the cursor LEFT/RIGHT keys, it is possible to:

- (de)activated the selected menu item (e.g. LOAD DEFAULT)
- change the value of the selected menu item
- activate the selected submenu (e.g. GEOMETRY)

ACCES TO NORMAL USER MENU

Pressing the "MENU" button on the remote control switches between the SDM and the normal user menus (with the SAM mode still active in the background). Pressing the MENU key in a submenu will go to the previous menu.

The menus and submenus**ERASE BUFFER**

Erasing the contents of the error buffer. Select the ERASE BUFFER menu item and press the MENU RIGHT key. The contents of the error buffer is cleared.

RELOAD DEFAULT

Reloading memory default values. All default settings can be reloaded into the memory (EEPROM). Select the RELOAD DEFAULT menu item and press the MENU RIGHT key. Select LOAD NOW and press MENU RIGHT to reload all settings, then switch the set to STANDBY. The default settings are activated when the set is switched on. CAUTION! Use this menu with extreme care. Otherwise customer settings will be lost.

The functionality of the OPTIONS and ALIGNMENTS (GEOMETRY, GEOMETRY SW, WHITE TONE, TUNER & BTSC SOUND) sub menus is described in chapter 8.

5.3 Error code buffer and error codes**5.3.1 Error code buffer**

The error code buffer contains all errors detected since the time the buffer was erased. The buffer is written from left to right.

- when an error occurs that is not yet in the error code buffer the error is written at the left side and all other errors are shifted one position to the right
- the error code buffer will be cleared in the following cases:
 1. exiting SDM or SAM with the "Standby" command via the remote control
 2. transmitting the commands "DIAGNOSE 99 OK" via the DST (RC7150) or with Compair
- The error buffer will be automatically reset if its contents have not changed for 50 hours
- By leaving SDM or SAM with the mains switch, the error buffer is not reset.

Examples:

ERROR: 0 0 0 0 0 0: No errors detected

ERROR: 6 0 0 0 0 0: Error code 6 is the last and only detected error

ERROR: 5 6 0 0 0 0: Error code 6 was first detected and error code 5 is the last detected (newest) error

5.3.2 Error codes

In case of a non-intermittent faults, clear the error buffer before starting the repair to prevent that "old" error codes are present. When possible check the entire content of the error buffers. In some situations an error code is only the RESULT of another error code (and not the actual cause).

Note: a fault in the protection detection circuitry can also lead to a protection.

Error 0 = No error

Error 1 = X-ray protection, E/W protection and/or Vertical protection. X-ray protection, E/W protection and/or Vertical protection active; set is switched to protection; error code is placed in the error buffer; the LED will blink 1 time (repeated). If this happens, isolate each circuit to determine the cause. These circuits are:

- X-Ray protection:
- If this protection is active, the most likely cause is the L
- EW protection:
- If this protection is active, the causes could be one of the following:
 - bad contacts of:
 - horizontal deflection coil
 - linearity coil 5621
 - S-correction capacitor 2629/2630
 - flyback capacitor 2613/2625
 - line output stage
 - short circuit of:
 - flyback diode 6621

- EW transformer (bridge coil) 5624/5625 or 5680/5682/5683 (version dependent)
- S-correction capacitor 2629/2630
- EW driver 7680

- Vertical protection:
- If this protection is active, the causes could be one of the following (most likely in the vertical output stage):
 - 7700 is faulty
 - poor contact or open circuit of deflection coil
 - +13V_+20V and/or -13V not present

Error 2 = High beam current protection. High beam protection active; set is switched to protection; error code 2 is placed in the error buffer; the LED will blink 2 times (repeatedly). As the name implies, the cause of this protection is a too high beam current (bright screen with flyback lines). Check whether the +200V supply to the CRT panel is present. If the voltage is present, the most like cause is the CRT panel or the picture tube. Disconnect the CRT panel to determine the cause. If the +200V voltage is not present, check R3840, R3643 and D6641.

Error 3 = Reserved

Error 4 = +5V protection. 5V protection active; set is switched to protection; error code 4 is placed in the error buffer; the LED will blink 4 times (repeatedly). A 5V failure can cause a drop in the 5V supply output, resulting in undefined behaviour of the set. Therefore, all I2C devices connected to the 5V supply are constantly monitored. When non of these devices responds to the micro controller for a prolonged time, the micro controller assumes that there is a failure in the 5V supply. By starting up the set with the service jumpers shorted, the 5V protection is disabled and it is easier to determine the cause.

+5V protection will be activated when these I2C devices fail (no I2C communication):

- Main Tuner 1125 on main panel
- ITT sound processor IC7430 on main panel
- PIP tuner (if present) on DW or YC PIP panel
- OSD generator IC7101 on OSD panel

The following tips are useful to isolate the problem area after overriding the +5V protection. Determine whether:

1. the +5V source is working properly; isolate coil 5430 and jumper 9044 and measure the +5V
2. ITT sound processor circuit is loading the +5V; isolate coil 5430
3. the main tuner, PIP tuner, or OSD circuitry is loading the +5V source; isolate jumper 9044
4. main tuner circuit is loading the +5V source; isolate coil 5100
5. OSD or PIP circuit is loading the +5V source; unplug the panel
6. PIP circuit is loading the +5V source; unplug J9Q2 (DW) or P07 (YC) on panel

Caution! Overriding the 5V protection when there is a 5V failure can increase the temperature in the set and may cause permanent damage to components. Do not override the 5V protection for a prolonged time.

Error 5 = Bimos software protection active (Bimos start-up register is corrupted or the I2C line to the Bimos is always low or no supply at pin 12 of the BIMOS). This error is usually detected during start-up and hence will prevent the set from starting up. Note that this error may also be reported as a result

Error 6 = Bimos (TDA884X) I2C error. Note that this error r also be reported as a result of error codes 1 or 2 (in that c: the Bimos might not be the actual problem)

Error 7 = General I2C error. This will occur in the following cases:

- SCL or SDA is shorted to ground
- SCL is shorted to SDA
- SDA or SCL connection at the micro controller is open circuit.

Error 8 = Microprocessor internal RAM error. The micro controller internal RAM test indicated an error of the micro controller internal memory (tested during start-up);

Error 9 = OSD generator I2C error (PCA8516). PCA8516 d: not respond to the micro controller

Error 10 = NV memory I2C error. NV memory (EEPROM) d: not respond to the micro controller

Error 11 = micro controller / NV Memory identification error. During the last start-up the NVM and the micro controller d not recognize each other (e.g. one of them was replaced), therefore the NVM was loaded with default values.

Error 12 = YUV IC I2C error (TDA9178). TDA9178 does no respond to the micro controller

Error 13 = Reserved

Error 14 = Sound processor I2C error (MSP34XX/TDA9855). Sound controller MSP3400, MSP3410 or TDA9855 does n respond to the micro controller

Error 15 = Reserved

Error 16 = PLL tuner I2C error. The PLL tuner does not resp: to the micro controller

Error 17 = PIP processor I2C error (MC4446X). PIP proces: MC4446x does not respond to the micro controller

Error 18 = 2nd tuner I2C error. The 2nd tuner (PIP/DW) doe: not respond to the micro controller

Error 19 = Reserved

Error 20 = Reserved

Error 21 = Reserved

Error 22 = Reserved

Error codes 1,2, 4 and 5 are protection codes and in this ca: supplies of some circuits will be switched off. Also, in protect: the LED will blink the number of times equivalent to the mc: recent error code.

5.3.3 Error code table

Table 5-1

Err or code	Error description	Possible defective components
0	No error detected	-
1	X-ray protection / EW and/or Vert protection active	EW/Vertical circuit is defective
2	High beam protection active	CRT amplifier circuit or picture tube, or +200V is missing
3	Reserved	
4	5V protection active	+5V supply line is low or short circuit
5	BIMOS	s/w protection active or BIMOS register is corrupted IC7150
6	BIMOS I2C	error IC7150
7	General I2C bus error	I2C bus s/c or o/c on uP
8	Main uP Internal RAM error	IC7000
9	OSD generator I2C error	IC7101 on OSD panel
10	NVM I2C error	IC7088
11	NVM identification error	IC7088
12	Histogram I2C error	IC7770 on YUV interface panel
13	Reserved	
14	Sound processor I2C error	IC7430 (2CS/ Nicam) or IC7437 (BTSC)
15	Reserved	
16	Main tuner I2C error	U1125
17	PIP processor I2C error	IC7350 on PIP panel
18	2nd tuner PIP I2C error	U1126 or U1127 on PIP panel
19	Reserved	
20	Reserved	
21	Reserved	
22	Reserved	

5.4 The "blinking LED" procedure

The contents of the error buffer can also be made visible through the "blinking LED" procedure. This is especially useful when there is no picture. There are two methods:

1. When the SDM is entered, the LED will blink the number of times, equal to the value of the last (newest) error code (repeatedly).
2. With the DST all error codes in the error buffer can be made visible. Transmit the command:

"DIAGNOSE x OK" where x is the position in the error buffer to be made visible

x ranges from 1, (the last (actual) error) to 6 (the first error)

The LED will operate in the same way as in point 1, but now the error code on position x.

Example:

Error code position 1 2 3 4 5 6

Error buffer: 8 9 5 0 0 0

- after entering SDM
- blink (8x) - pause - blink (8x) - etc.
- after transmitting "DIAGNOSE 2 OK" with the DST blink (9x) - pause - blink (9x) - etc.
- after transmitting "DIAGNOSE 3 OK" with the DST blink(5x) - pause - blink(5x) - etc.
- after transmitting "DIAGNOSE 4 OK" with the DST nothing happens

NOTE: If errors 1, 2, 4 or 5 occurs the LED ALWAYS blinks last occurred error, even if the set is NOT in service mode

5.5 Trouble shooting tips

In this paragraph some trouble shooting tips for the deflection and power supply circuitry are described. For detailed diagnostics, check the fault finding tree.

5.5.1 THE DEFLECTION CIRCUIT:

1. Measure the VBAT (140V) is present across 2917 (A1 POWER SUPPLY). If the voltage is not present, disconnect coil 5930 (A1 Power Supply) (whole horizontal deflection stage is disconnected). If the voltage is present then the problem might be caused by the deflection circuit.
Possibilities:
 - Transistor 7620 is faulty
 - The driver circuit around transistor 7610 is faulty
 - No horizontal drive signal coming from the BIMOS 7150-D pin 40
2. Note: If the C and E of 7620 is shorted, hick-up noise can be heard from the power supply circuit.
3. To determine whether the fault is present in the horizontal deflection circuit (A2 HOR .DEFLECTION+LINE OUTPUT) or in the EW circuit/panel (screen size above 21"), disconnect E61 pin 13 or M61 pin 13 (in this case the EW protection is disabled) and insert jumpers into positions 9605 and 9614. If the basic deflection is working (picture is not distorted), then the fault is located in the EW circuit/panel. If there is no horizontal deflection, the fault is present in the horizontal deflection circuitry.
4. Also take note of protection circuits in the line output stage. If any of these circuits are activated, the set will shutdown. Depending on protections, the LED will blink according to the fault defined. In order to determine which protection circuit is active, isolation of circuits is necessary. These protection circuits are:
 - High beam protection (LED blinks repetitively 2 times see error code 2 explanation).

- Any of the following protection circuit is active, it will cause LED to blink repetitively 1 times. If this happen, isolate each circuit to determine the cause.; see error code 1.

2 THE POWER SUPPLY.

To trouble shoot the A8 SMPS, first check the +5V_STBY voltage on IC7907, pin 7. If this voltage is not present, check fuse 1906 and D6917. If 1906 or D6917 is not open circuit, the problem might be caused on the primary side of the switching supply. Check the output of the bridge diodes on the cathode side of D6931/D6903 pin 1 for approximately 300V DC. If this voltage is missing, check the bridge diodes and the fuse 1900 on the mains filter panel (H circuit). If fuse F1900 is found open, check IC7902 (circuit A1) between pins 3 and 2 to make sure that there is no short circuit present. If the 300V DC is present on pin 3 of IC7902, check for a startup voltage of 16V on pin 4 of IC7902. If no startup voltage is present, check if R3917 is open; a short circuit between pin 4 and 5 will also cause this problem. It is necessary to have a feedback signal from the hot secondary side of switch mode transformer T5912 at pin 8 and pin 9 for the power supply to oscillate. If this startup voltage is present on pin 4 of IC7902 and the supply is not oscillating, check R3959 and D6908.

The A8 powersupply has been designed with Over Voltage Protection (OVP). To determined whether OVP is active, check whether +5V standby is present at IC7907 pin 7. If not, check the components 1905, 6914, 6960, 3926 and 3920. If these components are O.K., then replace opto-coupler 7950.

Another way to confirm whether OVP is active is to measure the voltage with an oscilloscope at IC7902 pin 4. If the voltage is fluctuating between 11-14V, then check the components as described in the above mentioned paragraph.

Customer Service Mode (CSM)

All A8.0 sets are equipped with the "Customer Service Mode" (CSM). CSM is a special service mode that can be activated and deactivated by the customer, upon request of the service technician/dealer during a telephone conversation in order to identify the status of the set. This CSM is a 'read only' mode, therefore modifications in this mode are not possible.

Entering the Customer Service Mode.

The Customer Service Mode can be switched on by pressing simultaneously the button (MUTE) on the remote control and any key on the control buttons (P+, P-, VOL +, VOL -) on the TV for at least 4 seconds.

When the CSM is activated:

- picture and sound settings are set to nominal levels
- modes that interfere with the behaviour of the set are switched off (sleep timer, auto standby, etc.)

Exit the Customer Service Mode.

The Customer Service Mode will switch off after:

- switching off the TV set with the mains switch.

All settings that were changed at activation of CSM are set back to the initial values

5.6.1 The Customer Service Mode information screen

After switching on the Customer Service Mode the following screen will appear.

CSM Menu

```

1  n n n n  A A A B B C - X . Y  D D D D - E - F F      C S
2  C O D E S   n n   n n   n n   n n   n n   n n
3  O P     n n n   n n n   n n n   n n n   n n n   n n r
4  S Y S           H O S P
5  S L E E P       N O T   T U N E D
6  L O C K         S K I P P E D
7  T I M E R

```

CL 86532036_1
21

Figure 5-3 Customer Service Mode screen

The Customer Service Menu shows the following information:

- "nnnnn" displayed on line 1

Hexadecimal counter of operating hours. Standby hours are not counted as operating hours.

- "A80BBC-X.Y" displayed on line 1

Software identification of the main micro controller. See paragraph 5.2. Details on available software versions can be found in the chapter "Software Survey" of the publication "Product Survey - Colour Television".

- "CODES xx xx xx xx xx xx" displayed on line 2

Error code buffer (see paragraph 5.3). Displays the last 6 errors of the error code buffer. As soon as the built-in diagnostic software has detected an error the buffer is adapted. The latest (=newest) error is displayed on the leftmost position. Each error code is displayed as a 1 or 2 digit number. When less than 6 errors occur, the rest of the position(s) is(are) displayed as spaces. See paragraph 5.3 of this chapter for a detailed description of the error codes.

- "OP xxx xxx xxx xxx xxx xxx" displayed on line 3

Option bytes. Software and hardware functionality of the A8 is controlled by option bits. An option byte or option number represents 8 of those bits. Each option number is displayed as a decimal number between 0 and 255. The set may not work correctly when an incorrect option code is set. See chapter 5.3 for more information on correct option settings.

- "SYS XXXXX" displayed on line 4

Indicates which colour and sound system is installed for the preset:

- AUTO
- PAL BG
- PAL I
- PAL DK

Complaints that may be caused by an incorrect system setting:

- no colours
- colours not correct
- unstable picture
- noise in picture
- distorted sound / no sound

To change the system setting of a preset:

- press the "MENU" button on the remote control
- select the INSTALL sub menu
- select the MANUAL STORE sub menu
- select and change the SYSTEM setting until picture and sound are correct
- select the STORE menu item

"HOSP" displayed on line 4 of the CSM menu. Indicates that the "hospitality" mode is enabled. Complaints that may be caused by the activation of "hospitality mode":

- "HOSPITALITY ON" displayed on TV screen
- Installation menu does not work
- Personal presets are not automatically stored
- Volume level cannot be increased above a certain level
- Some channels/presets are blanked (only audio)

To switch off the hospitality mode:

- go to preset 38
- press the "OSD" and "MENU" buttons on the local keyboard simultaneously for 3 seconds

- "SLEEP" displayed on line 5 of the CSM screen

Indicates that the sleep timer is running. Complaints that may be caused by the activation of the sleep timer:

- set displays "GOOD BYE" and switches to standby

To switch off the sleep timer:

- press the top left button on the remote control until repeatedly until "SLEEP 0" is displayed in the middle of the screen.

- "NOT TUNED" on line 5 of the CSM screen.

Indicates that the set is not receiving an "ident" signal on this channel / preset. Situations which can will result in the display of "NOT TUNED":

- no or bad antenna signal; connect a proper antenna signal
- antenna not connected; connect the antenna
- no channel / preset is stored at this program number; go to the INSTALL menu and store a proper channel at this program number
- the tuner is faulty (in this case the CODES line will contain number 16); check the tuner and replace/repair if necessary

Note: On some models, BLUE MUTE is displayed (if the BM option is ON) when no signal is received.

- "LOCK" on line 6 of the CSM screen

On Pal/Multi sets:

Indicates that all channels are locked except the selected channel. Complaint that may be caused by locked channels:

- TV cannot be switched on from standby with the local keyboard buttons

- "P+" and "P-" buttons on local keyboard do not function

To disable the LOCK feature:

1. select "FEATURE" menu (with the Remote Control)
2. select "LOCK" (with the RC)
3. set to "OFF"

On NTSC sets:

Indicates if the channel is blocked via the parental or sma lock. To switch off the parental lock

1. select the blocked channel
2. give in the 4 digit access code

To change the parental code when the code is "lost":

1. select "FEATURE" menu
2. select "PARENTAL LOCK"
3. select "SETUP CODE"
4. key in "0711"
5. key in "0711" again

The parental code is now 0711.

- "SKIPPED" displayed on line 6 of the CSM screen.

Indicates that at least one channel is deleted as a preferred channels (by default, all channels are skipped. Note that "SKIPPED" will always be displayed in CSM unless all the channels are not skipped. A channel can be added as a selected channel to the list of preferred channels:

1. select "INSTALL" menu
2. select "CHANNEL EDIT"
3. select "ADD/DELETE"
4. set to "ADD" with the left/right cursor keys

- "TIMER" displayed on line 7 of the CSM screen.

Indicates that the on/off timer is running. Complaints that be caused by the activation of the sleep timer;

- Without using the remote control of the local keyboard set is switching:
 - on from standby;
 - to a different channel

To switch off the activation timer:

- select "TIMER" in the "FEATURE" menu
- select "ACTIVATE" in the "TIMER" menu
- set to "OFF" with the left/right cursor keys

5.6.2 Solving other problems

TV switched off or changed channel without any user action. Set switches off after "TV SWITCHING OFF" was displayed. Auto standby switched the set off because:

- there was no ident signal > 15 minutes
- there was no remote control signal received or local keyboard pressed for > 2 hours

See chapter 8 for a description on the options to enable/disable auto standby

Picture problems. Picture too dark or too bright

- Press "Smart Picture" button on the remote control. In the picture improves, increase / decrease the brightness

5 Service modes, error messages and repair tips

value or increase / decrease the contrast value. The new "Personal Preference" value is automatically stored after 3 minutes

- After switching on the Customer Service Mode the picture is OK. Increase / decrease the brightness value or increase / decrease the contrast value. The new "Personal Preference" value is automatically stored after 3 minutes

White line around picture elements and text

- press "Smart Picture" button on the remote control. In case the picture improves, decrease the sharpness value. The new "Personal Preference" value is automatically stored after 3 minutes
- after switching on the Customer Service Mode the picture is OK. Decrease the sharpness value. The new "Personal Preference" value is automatically stored after 3 minutes

Snowy picture

- check the "NOT TUNED" section of the Customer Service Mode screen

Snowy picture and/or unstable picture

- a scrambled or decoded signal is received

Black and white picture

- press "Smart Picture" button on the remote control. In case picture improves, increase the colour value. The new "Personal Preference" value is automatically stored after 3 minutes
- after switching on the Customer Service Mode the picture is OK. Increase the colour value. The new "Personal Preference" value is automatically stored after 3 minutes

Menu text not sharp enough

- press "Smart Picture" button on the remote control. In case the picture improves, decrease the contrast value. The new "Personal Preference" value is automatically stored after 3 minutes
- after switching on the Customer Service Mode the picture is OK. Decrease the contrast value. The new "Personal Preference" value is automatically stored after 3 minutes

Sound problems.

No sound or sound too loud (after channel change / switching on)

- after switching on the Customer Service Mode the volume is OK. Increase / decrease the volume level. The new "Personal Preference" value is automatically stored after 3 minutes