



12AX7

TWIN TRIODE

DESCRIPTION AND RATING

The 12AX7 is a miniature high-mu twin triode each section of which has an individual cathode connection. The 12AX7 is especially suited for use in resistance-coupled voltage amplifiers, phase inverters, multivibrators, and numerous industrial-control circuits where high voltage gain is desired. A center-tapped heater permits operation of the tube from either a 6.3-volt or a 12.6-volt heater supply.

GENERAL

Cathode—Coated Unipotential

	Series	Parallel
Heater Voltage, AC or DC	12.6	6.3 Volts
Heater Current	0.15	0.3 Amperes
Envelope—T-6½, Glass		
Base—E9-1, Small Button 9-Pin		
Mounting Position—Any		

Direct Interelectrode Capacitances

	With Shield*	Without Shield
Grid to Plate, Each Section	1.7	1.7 μμf
Input, Each Section	1.8	1.6 μμf
Output, Section 1	1.9	0.46 μμf
Output, Section 2	1.9	0.34 μμf

MAXIMUM RATINGS

DESIGN-CENTER VALUES, EACH SECTION

Plate Voltage	300	Volts
Positive DC Grid Voltage	0	Volts
Negative DC Grid Voltage	50	Volts
Plate Dissipation	1.0	Watts
Heater-Cathode Voltage		
Heater Positive with Respect to Cathode	180	Volts
Heater Negative with Respect to Cathode	180	Volts

CHARACTERISTICS AND TYPICAL OPERATION

CLASS A₁ AMPLIFIER, EACH SECTION

Plate Voltage	100	250	Volts
Grid Voltage	-1	-2	Volts
Amplification Factor	100	100	
Plate Resistance, approximate	80000	62500	Ohms
Transconductance	1250	1600	Micromhos
Plate Current	0.5	1.2	Milliamperes

* With external shield (RETMA 315) connected to cathode of section under test.

BASING DIAGRAM

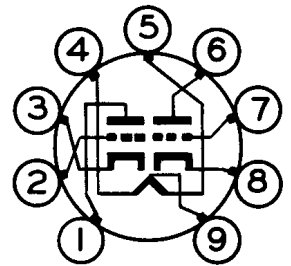

RETMA 9A
BOTTOM VIEW

TERMINAL CONNECTIONS

- Pin 1—Plate (Section 2)
- Pin 2—Grid (Section 2)
- Pin 3—Cathode (Section 2)
- Pin 4—Heater
- Pin 5—Heater
- Pin 6—Plate (Section 1)
- Pin 7—Grid (Section 1)
- Pin 8—Cathode (Section 1)
- Pin 9—Heater Center-Tap

PHYSICAL DIMENSIONS

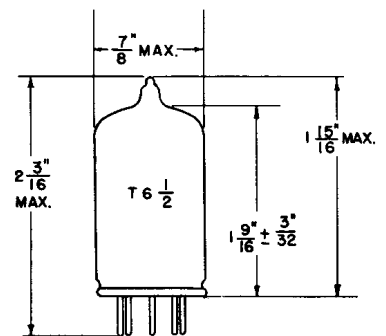

RETMA 6-2



CLASS A RESISTANCE-COUPLED AMPLIFIER

EACH SECTION

Rp Meg.	Rs Meg.	Rg1 Meg.	Ebb = 90 Volts			Ebb = 180 Volts			Ebb = 300 Volts		
			Rk	Gain	Eo	Rk	Gain	Eo	Rk	Gain	Eo
0.10	0.10	0.1	1700	31	5.0	1000	40	15	760	43	30
0.10	0.24	0.1	2000	38	6.9	1100	46	20	900	50	40
0.24	0.24	0.1	3500	43	6.5	2000	54	18	1600	58	37
0.24	0.51	0.1	3900	49	8.6	2300	59	24	1800	64	47
0.51	0.51	0.1	7100	50	7.4	4300	62	19	3100	66	39
0.51	1.0	0.1	7800	53	9.1	4800	64	24	3600	69	46
0.24	0.24	10	0	37	3.9	0	53	15	0	62	32
0.24	0.51	10	0	44	5.4	0	60	19	0	67	41
0.51	0.51	10	0	44	5.0	0	61	17	0	69	35
0.51	1.0	10	0	49	6.4	0	66	21	0	71	41

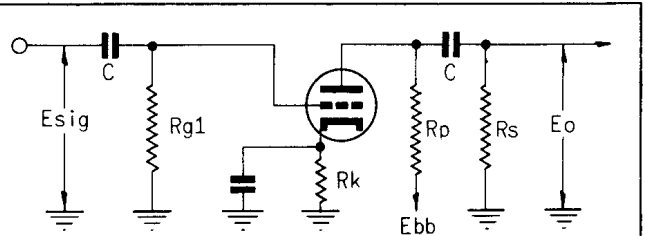

Note: Coupling capacitors (C) should be selected to give desired frequency response. Rk should be adequately by-passed.

Notes: 1. Eo is maximum RMS voltage output for five percent (5%) total harmonic distortion. 2. Gain measured at 2.0 volts RMS output. 3. For zero-bias data, generator impedance is negligible.

AVERAGE CHARACTERISTICS

140 140000 EACH SECTION 2800

AVERAGE PLATE CHARACTERISTICS

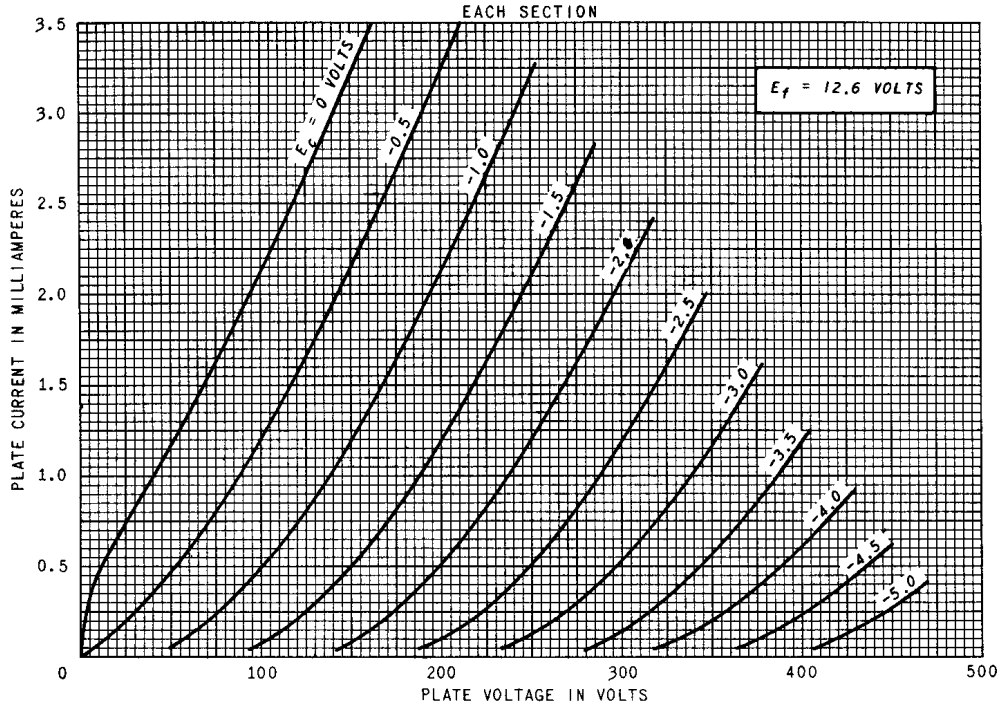

AVERAGE TRANSFER CHARACTERISTICS

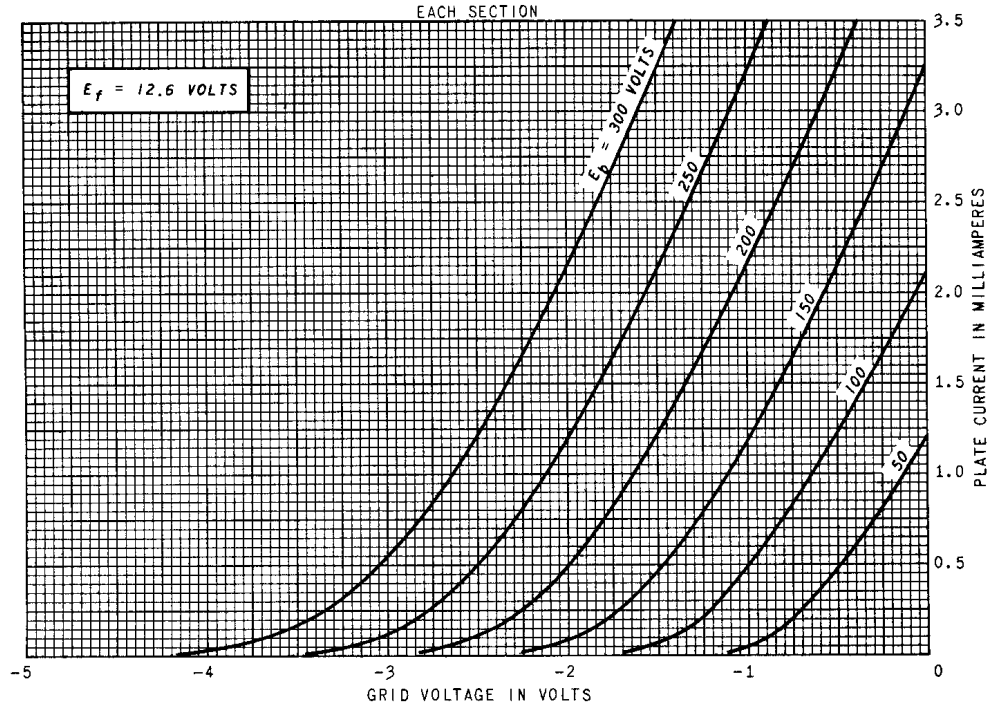

AVERAGE CHARACTERISTICS
 EACH SECTION

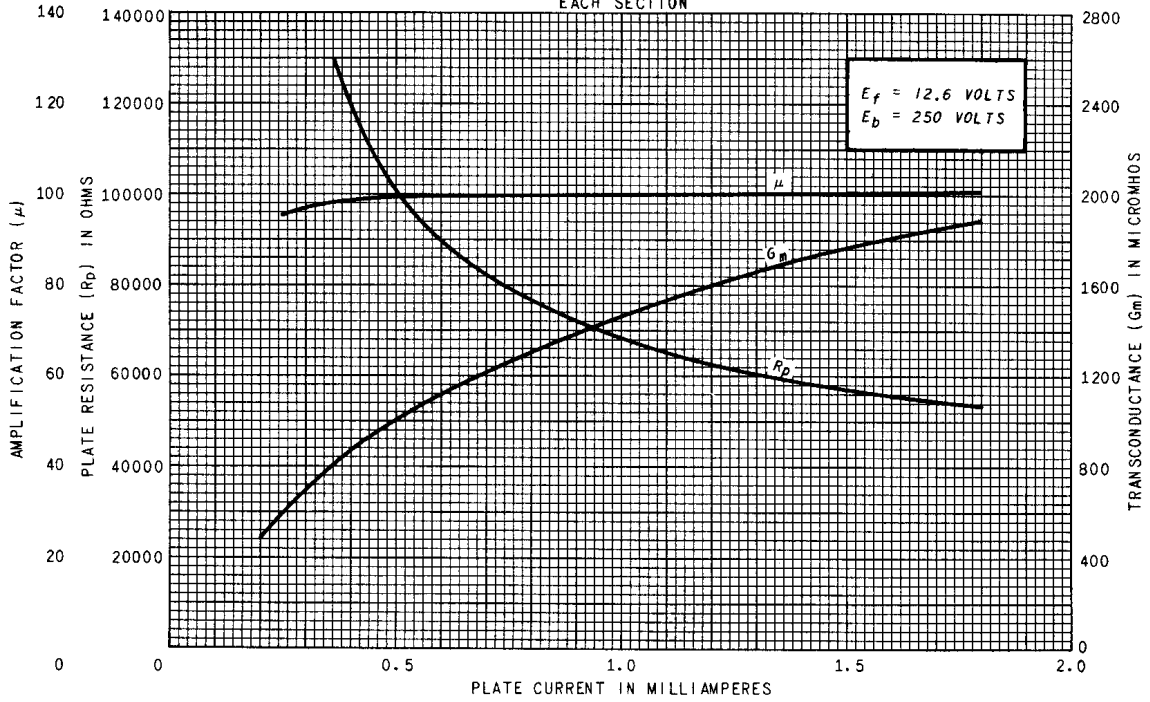

TUBE DEPARTMENT



Schenectady 5, N. Y.