



europaean space agency
agence spatiale européenne

Pages 1 to 18



OPTO-ISOLATORS

BASED ON TYPES 3C91 AND 3C92

ESA/SCC Detail Specification No. 5401/001

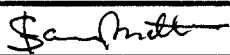

**space components
coordination group**

Issue/Rev.	Date	Approved by	
		SCCG Chairman	ESA Director General or his Deputy
Issue 4	May 1998		

**DOCUMENTATION CHANGE NOTICE**

Rev. Letter	Rev. Date	Reference	CHANGE Item	Approved DCR No.
		This Issue supersedes Issue 3 and incorporates all modifications defined in Revisions 'A', 'B', 'C', 'D' and 'E' to Issue 3 and the changes agreed in the following DCR's:-		
		Cover page		None
		DCN		None
		Para. 1.2	: Existing text deleted and new text added	221471
		Para. 2	: Item "(e)" deleted	221471
		Table 1(b)	: No. 8, "(Note 1)" added to Remarks	221471
			: No. 12, Remarks deleted and "Note 2" added	221471
			: No. 13, New No. 13 added	221471
			: Note 2 added	221471
		Figure 1	: LED derating corrected to "80" start point	221471
			: Undertitle added	221471
			: Note added	221471
		Figure 2	: Imperial measurements deleted from Table	221471
		Figure 3	: Secondary Titles amended	221471
		Para. 4.2.2	: (a) Paragraph reference added	221471
			: (b) Paragraph reference added and text amended	221471/ 221428
		Para. 4.2.3	: (a) First sentence amended	221471
			(1) Paragraph reference added and text extended	221471
			(2) Paragraph reference added and text extended	221471
			: (b) Paragraph reference added and text amended	221471
			: (c) Paragraph reference added, text amended and (b) and (c) reversed in sequence	221471/ 221428
		Para. 4.2.4	: (a) Paragraph reference added	221471
			: (b) Paragraph reference added	221471
			: (c) Paragraph reference added, text amended and (b) and (c) reversed in sequence	221471/ 221428
		Para. 4.2.5	: (a) Paragraph reference added	221471
			: (b) Paragraph reference added, text amended and (a) and (b) reversed in sequence	221471/ 221428
		Para. 4.4.2	: Text amended	221471
		Para. 4.5.1	: Existing text deleted and new text added	221471
		Para. 4.5.5	: Deleted in toto	221471
		Para. 4.6.1	: Beginning of second sentence amended	221471
		Para. 4.7.2	: New Para. 4.7.2 added	221471
			: Existing paragraph renumbered to "4.7.3", "Power" added to Title and text and "5" amended to "5(b)"	221471
		Para. 4.7.3	: Renumbered as "4.7.5", "Power" added to Title and text and "5" amended to "5(b)"	221471
		Para. 4.7.4	: New Para. 4.7.4 added	221471
		Table 4(a)	: Title amended	221471
			: Column 4 heading and entries for columns 4 and 5 amended	221471
		Table 4(b)	: Title amended	221471
			: Column 4 heading and entries for columns 4 and 5 amended	221471
		Para. 4.8.1	: "Unless otherwise stated," added to the beginning of the second sentence	221471
		Para. 4.8.2	: Second sentence added	221471
		Para. 4.8.3	: Second sentence amended	221471
		Para. 4.8.4	: Text amended	221471
		Table 6	: Numbering aligned with Table 2 and format with Table 4	221471



 	ESA/SCC Detail Specification No. 5401/001		PAGE 3 ISSUE 4
---	--	--	-------------------

TABLE OF CONTENTS

		<u>Page</u>
1.	<u>GENERAL</u>	5
1.1	Scope	5
1.2	Component Type Variants	5
1.3	Maximum Ratings	5
1.4	Parameter Derating Information	5
1.5	Physical Dimensions	5
1.6	Functional Diagram	5
2.	<u>APPLICABLE DOCUMENTS</u>	5
3.	<u>TERMS, DEFINITIONS, ABBREVIATIONS, SYMBOLS AND UNITS</u>	5
4.	<u>REQUIREMENTS</u>	9
4.1	General	9
4.2	Deviations from Generic Specification	9
4.2.1	Deviations from Special In-process Controls	9
4.2.2	Deviations from Final Production Tests	9
4.2.3	Deviations from Burn-in and Electrical Measurements	9
4.2.4	Deviations from Qualification Tests	9
4.2.5	Deviations from Lot Acceptance Tests	10
4.3	Mechanical Requirements	10
4.3.1	Dimension Check	10
4.3.2	Weight	10
4.3.3	Terminal Strength	10
4.4	Materials and Finishes	10
4.4.1	Case	10
4.4.2	Lead Material and Finish	10
4.5	Marking	10
4.5.1	General	10
4.5.2	Lead Identification	11
4.5.3	The SCC Component Number	11
4.5.4	Traceability Information	11
4.6	Electrical Measurements	11
4.6.1	Electrical Measurements at Room Temperature	11
4.6.2	Electrical Measurements at High and Low Temperatures	11
4.6.3	Circuits for Electrical Measurements	11
4.7	Burn-in Tests	11
4.7.1	Parameter Drift Values	11
4.7.2	Conditions for High Temperature Reverse Bias Burn-in	11
4.7.3	Conditions for Power Burn-in	11
4.7.4	Electrical Circuit for High Temperature Reverse Bias Burn-in	11
4.7.5	Electrical Circuit for Power Burn-in	11
4.8	Environmental and Endurance Tests	16
4.8.1	Electrical Measurements on Completion of Environmental Tests	16
4.8.2	Electrical Measurements at Intermediate Points and on Completion of Endurance Tests	16
4.8.3	Conditions for Operating Life Tests	16
4.8.4	Electrical Circuits for Operating Life Tests	16
4.8.5	Conditions for High Temperature Storage Test	16

	<p style="text-align: center;">ESA/SCC Detail Specification No. 5401/001</p>	<p>PAGE 4 ISSUE 4</p>
---	--	---------------------------

TABLES

		<u>Page</u>
1(a)	Type Variants	6
1(b)	Maximum Ratings	6
2	Electrical Measurements at Room Temperature - d.c. Parameters	12
	Electrical Measurements at Room Temperature - a.c. Parameters	12
3	Electrical Measurements at High and Low Temperatures	14
4(a)	Parameter Drift Values for High Temperature Reverse Bias Burn-in	14
4(b)	Parameter Drift Values for Power Burn-in	14
5(a)	Conditions for High Temperature Reverse Bias Burn-in	15
5(b)	Conditions for Power Burn-in	15
6	Electrical Measurements at Intermediate Points and on Completion of Endurance Testing	17

FIGURES

1	Parameter Derating Information	7
2	Physical Dimensions	8
3	Functional Diagram	8
4	Circuits for Electrical Measurements	13
5(a)	Electrical Circuit for High Temperature Reverse Bias Burn-in	15
5(b)	Electrical Circuit for Power Burn-in	15

APPENDICES (Applicable to specific Manufacturers only)

'A'	Agreed Deviations for HAFO (S)	18
-----	--------------------------------	----

**1. GENERAL****1.1 SCOPE**

This specification details the ratings, physical and electrical characteristics, test and inspection data for Opto-Isolators, based on Types 3C91 and 3C92. It shall be read in conjunction with ESA/SCC Generic Specification No. 5000, the requirements of which are supplemented herein.

1.2 COMPONENT TYPE VARIANTS

Variants of the basic type transistors specified herein, which are also covered by this specification, are given in Table 1(a).

1.3 MAXIMUM RATINGS

The maximum ratings, which shall not be exceeded at any time during use or storage, applicable to the opto-isolators specified herein are scheduled in Table 1(b).

1.4 PARAMETER DERATING INFORMATION

The derating information applicable to the opto-isolators specified herein is shown in Figure 1.

1.5 PHYSICAL DIMENSIONS

The physical dimensions of the opto-isolators specified herein are shown in Figure 2.

1.6 FUNCTIONAL DIAGRAM

The functional diagram showing lead identification, of the opto-isolators specified herein, is shown in Figure 3.

2. APPLICABLE DOCUMENTS

The following documents form part of this specification and shall be read in conjunction with it:-

- (a) ESA/SCC Generic Specification No. 5000 for Discrete Semiconductor Components.
- (b) MIL-STD-202, Test Methods for Electronic and Electrical Component Parts.
- (c) MIL-STD-750, Test Methods and Procedures for Semiconductor Devices.
- (d) MIL-STD-883, Test Methods and Procedures for Microelectronics.

3. TERMS, DEFINITIONS, ABBREVIATIONS, SYMBOLS AND UNITS

For the purpose of this specification, the terms, definitions, abbreviations, symbols and units specified in ESA/SCC Basic Specification No. 21300 shall apply.



TABLE 1(a) - TYPE VARIANTS

(1) VARIANT	(2) BASED ON TYPE	(3) I _C (mA) AT +22°C	(4) I _C (mA) AT -55°C	(5) I _C (mA) AT (NOTE 1)	(6) 3dB BANDWIDTH (kHz)	(7) LEAD MATERIAL AND FINISH
01	3C91B	2.0	1.5	2.0	100	D2
02	3C91C	4.0	3.0	4.0	100	D2
03	3C92B	2.0	1.5	2.0	100	D2
04	3C92C	4.0	3.0	4.0	100	D2
05	3C91C1	4.0	3.0	4.0	90	D2
06	3C92C1	4.0	3.0	4.0	90	D2

NOTES

1. These values are applicable after performance of environmental and endurance tests (Table 6).

TABLE 1(b) - MAXIMUM RATINGS

No.	CHARACTERISTICS	SYMBOL	MAXIMUM RATINGS	UNIT	REMARKS
1	Input to Output Voltage	V _{IN-OUT}	±500	V	
2	Input Diode Reverse Voltage	V _R	7.0	V	
3	Input Diode Forward Current	I _F	50	mA	
4	Input Diode Surge Forward Current	I _{FS}	3.0	A	Non-repetitive t _p = 100µs
5	Transistor Collector-Emitter Voltage	V _{CE}	50	V	
6	Transistor Collector Current	I _C	50	A	
7	Total Power Dissipation	P _{tot1}	230	mW	T _{amb} ≤ +25°C
8	LED Dissipation	P _{tot2}	80	mW	T _{amb} ≤ +70°C (Note 1)
9	Detector Dissipation	P _{tot3}	200	mW	T _{amb} ≤ +25°C (Note 1)
10	Operating Temperature Range	T _{op}	-55 to +125	°C	T _{amb}
11	Storage Temperature Range	T _{stg}	-55 to +125	°C	
12	Soldering Temperature	T _{sol}	+260	°C	Note 2
13	Thermal Resistance LED Detector	R _{TH(J-A)}	600 500	°C/W	

NOTES

1. For derating with temperature, see Figure 1.
2. Duration 5 seconds maximum at a distance of not less than 1.5mm from the device body and the same lead shall not be resoldered until 3 minutes have elapsed.

FIGURE 1 - PARAMETER DERATING INFORMATION

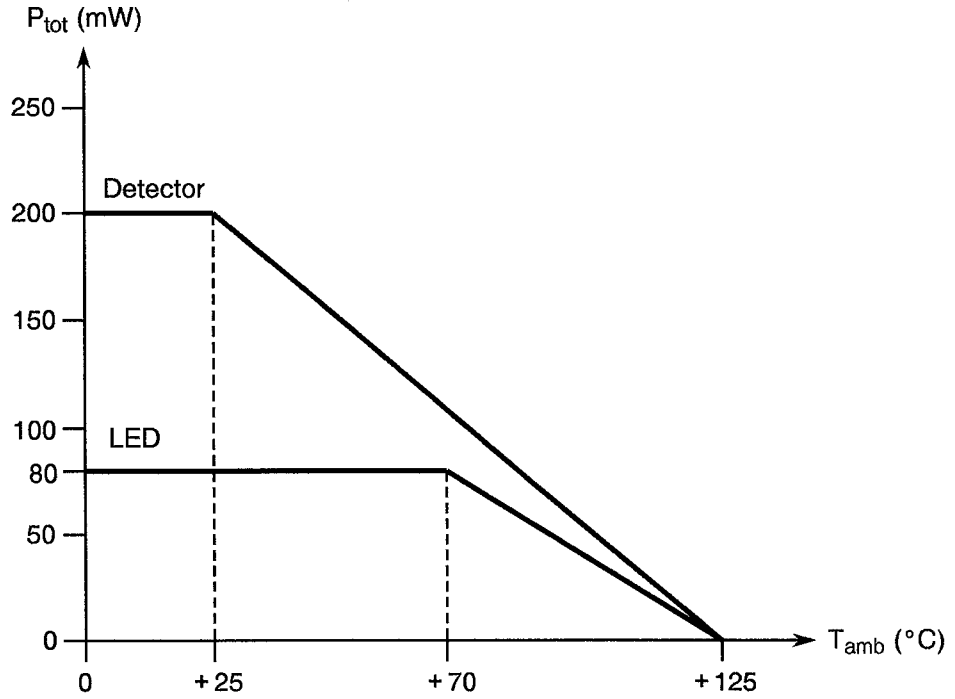

Power Dissipation versus Temperature

FIGURE 2 - PHYSICAL DIMENSIONS

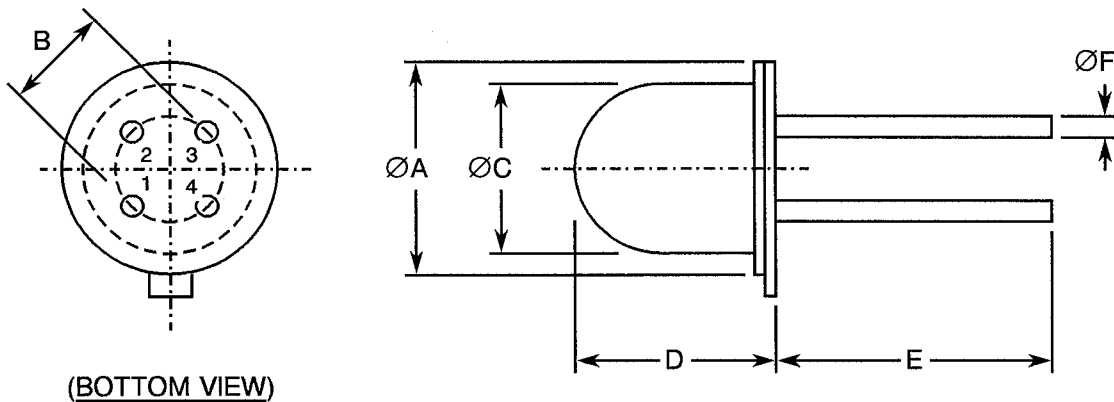

SYMBOL	MILLIMETRES	
	MIN.	MAX.
ØA	5.33	5.86
B	2.37	2.72
ØC	4.54	4.97
D	4.33	5.35
E	12.75	-
ØF	0.41	0.48

FIGURE 3 - FUNCTIONAL DIAGRAM

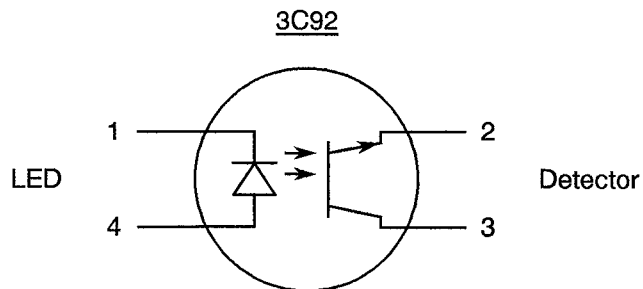
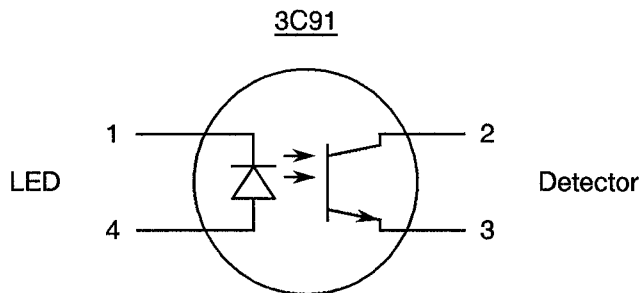



4. REQUIREMENTS

4.1 GENERAL

The complete requirements for procurement of the opto-isolators specified herein are stated in this specification and ESA/SCC Generic Specification No. 5000. Deviations from the Generic Specification, applicable to this specification only, are listed in Para. 4.2.

Deviations from the applicable Generic Specification and this Detail Specification, formally agreed with specific Manufacturers on the basis that the alternative requirements are equivalent to the ESA/SCC requirements and do not affect the components' reliability, are listed in the appendices attached to this specification.

4.2 DEVIATIONS FROM GENERIC SPECIFICATION

4.2.1 Deviations from Special In-process Controls

None.

4.2.2 Deviations from Final Production Tests (Chart II)



- (a) Para. 9.2.2, Die Shear Test: If the die area is smaller than 1.5×10^{-4} minimum forces as given in MIL-STD-883, Method 2019, shall apply.
- (b) Para. 9.10, External Visual Inspection: Shall be performed as specified in ESA/SCC Basic Specification No. 2055000. However, cracks in glass seal within the distance of one lead diameter from the lead, collection of bubbles which cannot be separated from each other or whose spatial distribution cannot be determined, shall not be cause for rejection.

4.2.3 Deviations from Burn-in and Electrical Measurements (Chart III)

- (a) The burn-in test shall be performed in 2 steps as specified below. The testing sequence shall be:-
 - (1) Transistor : Para. 7.1.1(a), High temperature reverse bias burn-in for full specified time with diode not operating, in accordance with Table 5(a) of this specification.
 - (2) LED : Para. 7.1.1(b), Power burn-in for full specified time with transistor not operating, in accordance with Table 5(b) of this specification.
- (b) Para. 9.10, External Visual Inspection: Shall be performed as specified in ESA/SCC Basic Specification No. 2055000. However, cracks in glass seal within the distance of one lead diameter from the lead, collection of bubbles which cannot be separated from each other or whose spatial distribution cannot be determined, shall not be cause for rejection.
- (c) Para. 9.12, Radiographic Inspection: Shall be performed on a 100% basis as specified in ESA/SCC Basic Specification No. 2095000, Figure 1 - Configuration C - Views 3, 4 and 5.

4.2.4 Deviations from Qualification Tests (Chart IV)

- (a) Para. 9.2.4, Die Shear Test: Shall be performed, if die area is smaller than 1.5×10^{-4} minimum forces as given in MIL-STD-883, Method 2019 shall apply.
- (b) Para. 9.10, External Visual Inspection: Shall be performed as specified in ESA/SCC Basic Specification No. 2055000. However, cracks in glass seal within the distance of one lead diameter from the lead, collection of bubbles which cannot be separated from each other or whose spatial distribution cannot be determined, shall not be cause for rejection.
- (c) Para. 9.20.1, Operating Life Test: Shall be performed on 50% of the parts defined in Subgroup IV as specified in Table 5(a) of this specification and on the other 50% as specified in Table 5(b) of this specification.

 	ESA/SCC Detail Specification No. 5401/001	PAGE 10 ISSUE 4
---	--	--------------------

4.2.5 Deviations from Lot Acceptance Tests (Chart V)

- (a) Para. 9.10, External Visual Inspection: Shall be performed as specified in ESA/SCC Basic Specification No. 2055000. However, cracks in glass seal within the distance of one lead diameter from the lead, collection of bubbles which cannot be separated from each other or whose spatial distribution cannot be determined, shall not be cause for rejection.
- (b) Para. 9.20.2, Operating Life Test: Shall be performed on 50% of the parts defined in LAT Level 2 as specified in Table 5(a) of this specification and on the other 50% as specified in Table 5(b) of this specification.

4.3 MECHANICAL REQUIREMENTS

4.3.1 Dimension Check

The dimensions of the opto-isolators specified herein shall be checked. They shall conform to those shown in Figure 2.

4.3.2 Weight

The maximum weight of the opto-isolators specified herein shall be 0.3 grammes.

4.3.3 Terminal Strength

The requirements for terminal strength testing are specified in Section 9 of ESA/SCC Generic Specification No. 5000. The test conditions shall be as follows:-

Test Condition: 'E', Lead Fatigue.
 Applied Force: 5.0 Newtons.

4.4 MATERIALS AND FINISHES

The materials and finishes shall be as specified herein. Where a definite material is not specified, a material which will enable the opto-isolators specified herein to meet the performance requirements of this specification shall be used. Acceptance or approval of any constituent material does not guarantee acceptance of the finished product.

4.4.1 Case

Can : Gold-plated Nickel.
 Header : Gold-plated Kovar.

4.4.2 Lead Material and Finish

The lead material shall be Type 'D' with Type '2' finish in accordance with the requirements of ESA/SCC Basic Specification No. 23500.

4.5 MARKING

4.5.1 General

The marking of all components delivered to this specification shall be in accordance with the requirements of ESA/SCC Basic Specification No. 21700 and the following paragraphs. When the component is too small to accomodate all of the marking specified, as much as space permits shall be marked and the marking information, in full, shall accompany the component in its primary package.

The information to be marked and the order of precedence, shall be as follows:-

- (a) Lead Identification.
- (b) The SCC Component Number.
- (c) Traceability Information.

4.5.2 Lead Identification

Lead identification shall be as shown in Figures 2 and 3.

4.5.3 The SCC Component Number

Each component shall bear the SCC Component Number which shall be constituted and marked as follows:-

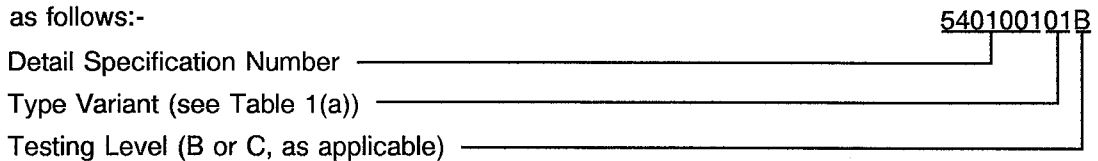

4.5.4 Traceability Information

Each component shall be marked in respect of traceability information in accordance with the requirements of ESA/SCC Basic Specification No. 21700.

4.6 ELECTRICAL MEASUREMENTS

4.6.1 Electrical Measurements at Room Temperature

The parameters to be measured at room temperature are scheduled in Table 2. Unless otherwise specified, measurements shall be performed at $T_{amb} = +22 \pm 3$ °C.

4.6.2 Electrical Measurements at High and Low Temperatures

The parameters to be measured at high and low temperatures are scheduled in Table 3.

4.6.3 Circuits for Electrical Measurements

Circuits for use in performing the electrical measurements listed in Tables 2 and 3 of this specification are shown in Figure 4.

4.7 BURN-IN TESTS

4.7.1 Parameter Drift Values

The parameter drift values applicable to burn-in are specified in Table 4 of this specification. Unless otherwise stated, measurements shall be performed at $T_{amb} = +22 \pm 3$ °C. The parameter drift values (Δ) applicable to the parameters scheduled shall not be exceeded. In addition to these drift value requirements, the appropriate limit value specified for a given parameter in Table 2 shall not be exceeded.

4.7.2 Conditions for High Temperature Reverse Bias Burn-in

The requirements for high temperature reverse bias burn-in are specified in Section 7 of ESA/SCC Generic Specification No. 5000. The conditions for high temperature reverse bias burn-in shall be as specified in Table 5(a) and Para. 4.2.3 of this specification.

4.7.3 Conditions for Power Burn-in

The requirements for power burn-in are specified in Section 7 of ESA/SCC Generic Specification No. 5000. The conditions for power burn-in shall be as specified in Table 5(b) and Para. 4.2.3 of this specification.

4.7.4 Electrical Circuit for High Temperature Reverse Bias Burn-in

A circuit for use in performing the high temperature reverse bias burn-in tests is shown in Figure 5(a) of this specification.

4.7.5 Electrical Circuit for Power Burn-in

A circuit for use in performing the power burn-in tests is shown in Figure 5(b) of this specification.

TABLE 2 - ELECTRICAL MEASUREMENTS AT ROOM TEMPERATURE - d.c. PARAMETERS

No.	CHARACTERISTICS (N.B.)	SYMBOL	SPEC. AND/OR TEST METHOD	TEST CONDITIONS	LIMITS		UNIT
					MIN	MAX	
1	Forward Voltage 1	V_{F1}	MIL-STD-750 Method 4011	$I_F = 2.0\text{mA}$	-	1.3	V
2	Forward Voltage 2	V_{F2}	MIL-STD-750 Method 4011	$I_F = 50\text{mA}$	-	1.8	V
3	Breakdown Voltage	V_{BR}	MIL-STD-750 Method 4021	$I_R = 0.1\text{mA}$	7.0	-	V
4	Collector-Emitter Breakdown Voltage	$V_{(BR)CEO}$	MIL-STD-750 Method 3011	$I_C = 10\text{mA}$	50	-	V
5	Dark Current	I_{CEO}	MIL-STD-750 Method 3036	$V_{CE} = 5.0\text{V}$ $I_F = 0\text{mA}$	-	50	nA
6	Output Current	I_C	MIL-STD-750 Method 3036	$V_{CE} = 5.0\text{V}$ $I_F = 10\text{mA}$	Note 1	-	mA
7	Collector-Emitter Saturation Voltage	$V_{CE(SAT)}$	MIL-STD-750 Method 3030	$I_C = 2.0\text{mA}$ $I_F = 50\text{mA}$	-	0.4	V
8	Isolation Voltage 1	$V_{IN} - V_{OUT}$	MIL-STD-202 Method 301	$t = 60\text{s}$ Notes 2 and 4	500	-	V
9	Isolation Voltage 2	$V_{IN} - V_{OUT}$	MIL-STD-202 Method 301	$t = 5.0\text{s}$ Note 3	800	-	V

TABLE 2 - ELECTRICAL MEASUREMENTS AT ROOM TEMPERATURE - a.c. PARAMETERS

No.	CHARACTERISTICS (N.B.)	SYMBOL	MIL-STD-750 TEST METHOD	TEST FIG.	TEST CONDITIONS (NOTE 4)	LIMITS		UNIT
						MIN	MAX	
10	Rise Time	t_r	-	4(a)	$R_L = 100\Omega$ $I_C = 2.0\text{mA}$ $V_{CE} = 5.0\text{V}$	-	5.0	μs
11	Fall Time	t_f	-	4(a)	$R_L = 100\Omega$ $I_C = 2.0\text{mA}$ $V_{CE} = 5.0\text{V}$	-	5.0	μs
12	3dB Bandwidth	f_{3dB}	-	4(b)	$R_L = 100\Omega$ $I_C = 2.0\text{mA}$ $V_{CE} = 5.0\text{V}$	Note 5	-	kHz

N.B.

Test Nos. 1 to 3 relate to LED, Test Nos. 4 to 5 relate to Detector, Test Nos. 6 to 12 relate to Coupled Device.

NOTES

1. See Column 3 of Table 1(a).
2. Measurement shall be performed after burn-in only.
3. Measurement shall be performed during final production tests only.
4. Measurements shall be performed on a sample basis, LTPD7 or less.
5. See Column 6 of Table 1(a).



FIGURE 4 - CIRCUITS FOR ELECTRICAL MEASUREMENTS

FIGURE 4(a) - SWITCHING TIME TEST CIRCUIT

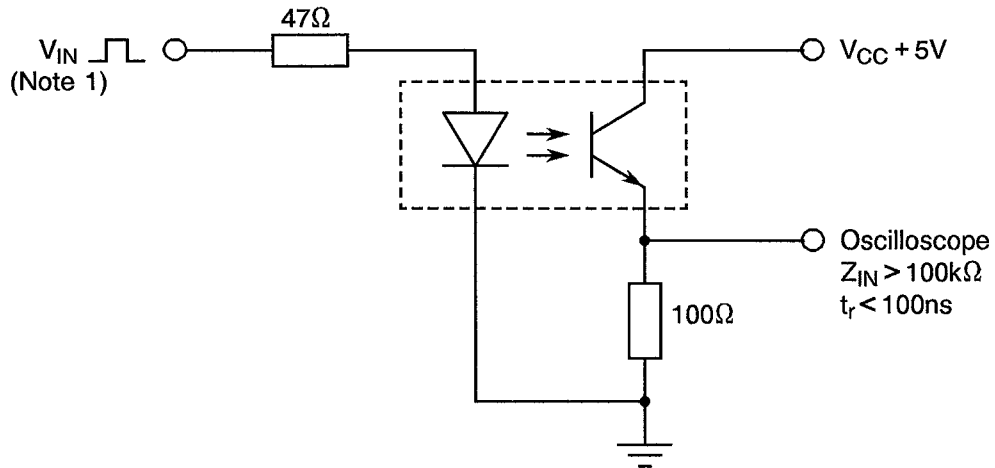

NOTES

1. V_{IN} conditions: $t_r < 10\text{ns}$, $t_p = 100\mu\text{s}$, $f = 100\text{Hz}$, $Z_g = 50\Omega$.

FIGURE 4(b) - FREQUENCY TEST CIRCUIT

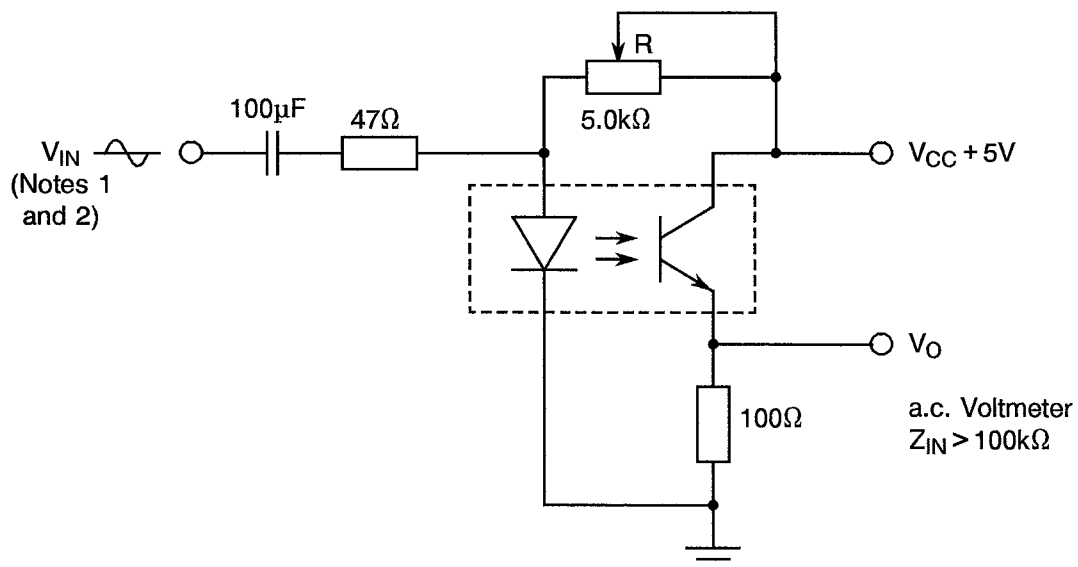

NOTES

1. $Z_g = 50$ to 100Ω .
2. Adjust R for $I_C = 2.0\text{mA}$
Adjust V_{IN} for $V_O = 10\text{mV}$ a.c. at 10kHz .
Increase f until $V_O = 7.0\text{mV} \approx f_{3\text{dB}}$.

TABLE 3 - ELECTRICAL MEASUREMENTS AT HIGH AND LOW TEMPERATURES

No.	CHARACTERISTICS	SYMBOL	MIL-STD-750 TEST METHOD	TEST CONDITIONS	LIMITS		UNIT
					MIN	MAX	
5	Dark Current	I_{CEO}	3036	$T_{amb} = +125^{\circ}C$ $V_{CE} = 5.0V$ $I_F = 0mA$	-	20	μA
6	Output Current	I_C	3036	$T_{amb} = -55^{\circ}C$ $V_{CE} = 5.0V$ $I_F = 10mA$	Note 1		mA

NOTES

- See Column 4 of Table 1(a).

TABLE 4(a) - PARAMETER DRIFT VALUES FOR HIGH TEMPERATURE REVERSE BIAS BURN-IN

No.	CHARACTERISTICS	SYMBOL	SPEC. AND/OR TEST METHOD	TEST CONDITIONS	CHANGE LIMITS (Δ)	UNIT
5	Dark Current	I_{CEO}	As per Table 2	As per Table 2	10 or (1) ± 100	nA %

NOTES

- Whichever is greater, referred to the initial value.

TABLE 4(b) - PARAMETER DRIFT VALUES FOR POWER BURN-IN

No.	CHARACTERISTICS	SYMBOL	SPEC. AND/OR TEST METHOD	TEST CONDITIONS	CHANGE LIMITS (Δ)	UNIT
6	Output Current	I_C	As per Table 2	As per Table 2	± 10	%

TABLE 5(a) - CONDITIONS FOR HIGH TEMPERATURE REVERSE BIAS BURN-IN

No.	CHARACTERISTICS	SYMBOL	CONDITIONS	UNIT
1	Ambient Temperature	T_{amb}	+ 125(+ 0 - 5)	°C
2	Diode Forward Current	I_F	0	mA
3	Collector-Emitter Voltage	V_{CE}	50	V
4	Duration	t	72	Hrs

TABLE 5(b) - CONDITIONS FOR POWER BURN-IN

No.	CHARACTERISTICS	SYMBOL	CONDITIONS	UNIT
1	Ambient Temperature	T_{amb}	+ 22 ± 3	°C
2	Diode Forward Current	I_F	50	mA
3	Collector-Emitter Voltage	V_{CE}	0	V

FIGURE 5(a) - ELECTRICAL CIRCUIT FOR HIGH TEMPERATURE REVERSE BIAS BURN-IN

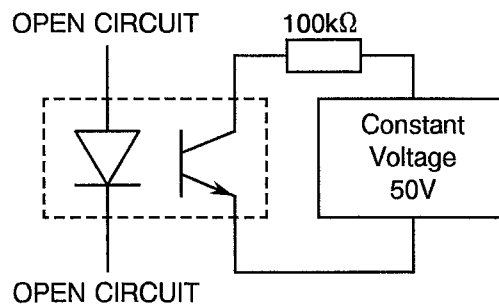
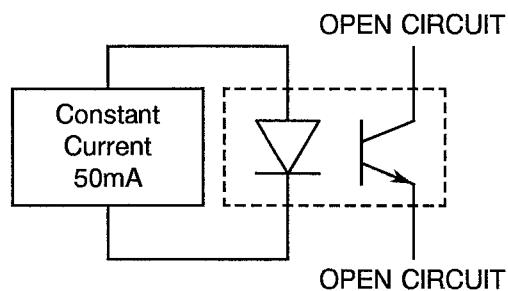

FIGURE 5(b) - ELECTRICAL CIRCUIT POWER BURN-IN





4.8 ENVIRONMENTAL AND ENDURANCE TESTS (CHARTS IV AND V OF ESA/SCC GENERIC SPECIFICATION NO. 5000)

4.8.1 Electrical Measurements on Completion of Environmental Tests

The parameters to be measured on completion of environmental tests are scheduled in Table 2. Unless otherwise stated, the measurements shall be performed at $T_{amb} = +22 \pm 3$ °C.

4.8.2 Electrical Measurements at Intermediate Points and on Completion of Endurance Tests

The parameters to be measured at intermediate points and on completion of endurance testing are scheduled in Table 6 of this specification. Unless otherwise stated, the measurements shall be performed at $T_{amb} = +22 \pm 3$ °C.

4.8.3 Conditions for Operating Life Tests (Part of Endurance Testing)

The requirements for operating life testing are specified in Section 9 of ESA/SCC Generic Specification No. 5000. The conditions for operating life testing shall be as specified in Paras. 4.2.4 or 4.2.5 of this specification.

4.8.4 Electrical Circuits for Operating Life Tests

The circuits for performance of the operating life tests shall be the same as shown in Figures 5(a) and 5(b) for high temperature reverse bias and power burn-ins.

4.8.5 Conditions for High Temperature Storage Test (Part of Endurance Testing)

The requirements for the high temperature storage test are specified in ESA/SCC Generic Specification No. 5000. The temperature to be applied shall be the maximum storage temperature specified in Table 1(b) of this specification.

**TABLE 6 - ELECTRICAL MEASUREMENTS AT INTERMEDIATE POINTS AND ON COMPLETION OF ENDURANCE TESTING**

No.	CHARACTERISTICS (N.B.)	SYMBOL	SPEC. AND/OR TEST METHOD	TEST CONDITIONS	LIMITS		UNIT
					MIN.	MAX.	
2	Forward Voltage 2	V_{F2}	As per Table 2	As per Table 2	-	1.8	V
3	Breakdown Voltage	V_{BR}	As per Table 2	As per Table 2	7.0	-	V
5	Dark Current	I_{CEO}	As per Table 2	As per Table 2	-	50	nA
6	Output Current	I_C	As per Table 2	As per Table 2	Note 1	-	mA
7	Collector-Emitter Saturation Voltage	$V_{CE(SAT)}$	As per Table 2	As per Table 2	-	0.4	V
8	Isolation Voltage 1	$V_{IN} - V_{OUT}$	As per Table 2	As per Table 2	500	-	V

N.B.

Test Nos. 2 to 3 relate to LED, Test No. 5 relates to Detector, Test Nos. 6 to 8 relate to Coupled Device.

NOTES

1. See Column 5 of Table 1(a).

	<p>ESA/SCC Detail Specification No. 5401/001</p>		<p>PAGE 18 ISSUE 4</p>
--	--	--	----------------------------

APPENDIX 'A'

Page 1 of 1

AGREED DEVIATIONS FOR HAFO (S)

ITEMS AFFECTED	DESCRIPTION OF DEVIATIONS
Para. 4.2.2	(a) Para. 9.1, Internal (pre-encapsulation) Visual Inspection: Shall be performed according to HAFO Document No. 00075-00-4, Visual Inspection, Level 'A' for the Photo Diode (LED) and according to HAFO Document No. IF 00037-004 for the visual inspection of the Photo Transistor (Detector).