

## EMG49, mounting bracket and wheel specification

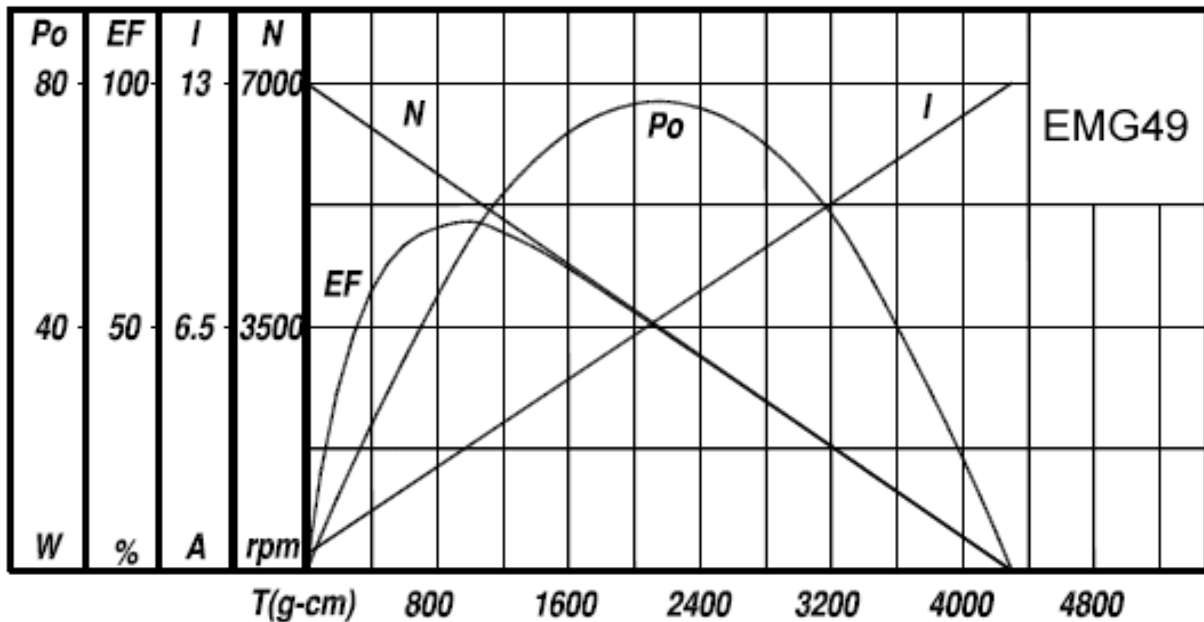

The EMG49 (encoder, motor, gearbox 49:1) is a 24v motor fully equipped with encoders and a 49:1 reduction gearbox. It is ideal for medium to large robotic applications, providing cost effective drive and feedback for the user. It also includes a standard noise suppression capacitor across the motor windings.

### Motor Characteristics



## Measurements

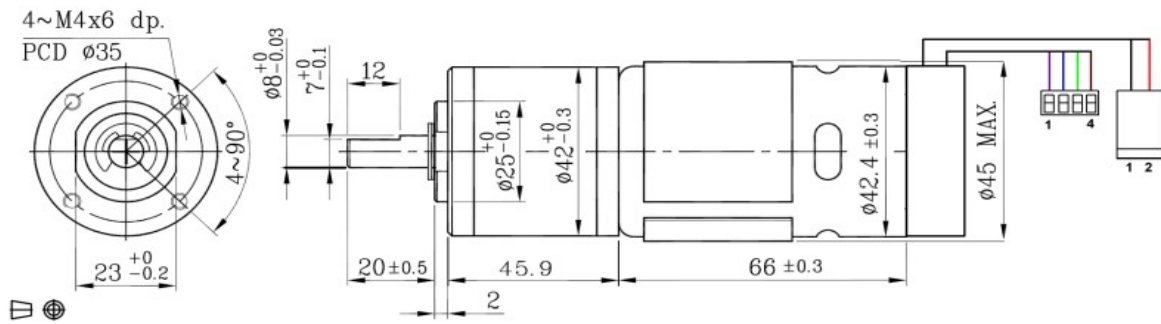

## Connectors

Motor power is connected with a two way 3.96mm pitch terminal Excon type 3961 and has 300mm of cable as standard.

Black (1) - Motor

Red (2) + Motor

The encoders connect using a 4 way JST connector (part no PHR-4) at the end of approx 300mm of cable as standard.

The connections are:

Wire colour	Connection
Purple (1)	Hall Sensor B Vout
Blue (2)	Hall sensor A Vout
Green (3)	Hall sensor ground
Brown (4)	Hall sensor Vcc

note that pull up resistors (we used 4k7) are required on the hall sensor outputs, and wires are the colours from the actual cable.

## Specification

Rated voltage	24v
Rated torque	16 kg/cm
Rated speed	122rpm
Rated current	2100mA
No load speed	143
No load current	500mA
Stall Current	13A
Rated output	34.7W
Encoder counts per output shaft turn	588

### EMG49 Mounting Bracket

Providing easy mounting of the EMG49 to the robot, the bracket is made from a 2mm thick strong aluminum and finished in blue enamel.

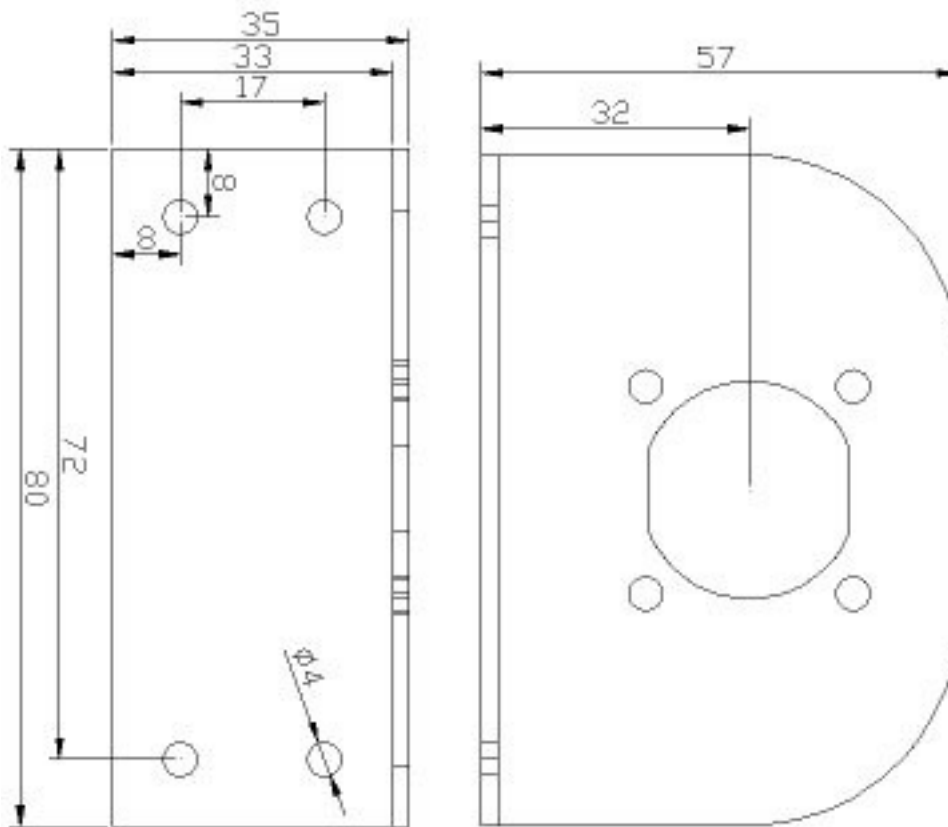

**Wheel 125**

A 125mm diameter wheel with 8mm diameter hub for easy attachment to the EMG49, the wheel has a 28mm wide rubber tread

