

# Rittal – The System.

Faster – better – everywhere.



Schaltschrank-Kühlgerät  
Cooling unit  
Climatiseur  
Koelaggregaat  
Kylaggregat  
Condizionatore per armadi  
Refrigerador para armarios  
エンクロージャー用  
クーリングユニット

3359.xxx  
3273.xxx  
3382.xxx  
3383.xxx

3384.xxx  
3385.xxx  
3386.xxx  
3387.xxx

Montage-, Installations- und Bedienungsanleitung  
Assembly and operating instructions  
Notice d'emploi, d'installation et de montage  
Montage- en bedieningshandleiding  
Montage- och hanteringsanvisning  
Istruzioni di montaggio e funzionamento  
Instrucciones de montaje y funcionamiento  
取扱説明書

ENCLOSURES

POWER DISTRIBUTION

CLIMATE CONTROL

IT INFRASTRUCTURE

SOFTWARE & SERVICES

FRIEDHELM LOH GROUP





## Contents

<b>1</b>	<b>Notes on documentation</b> .....	<b>4</b>	<b>5</b>	<b>Start-up</b> .....	<b>15</b>
1.1	Associated documents .....	4	<b>6</b>	<b>Operation</b> .....	<b>16</b>
1.2	CE labelling .....	4	6.1	Control using the e-Comfort controller ..	16
1.3	Retention of documents .....	4	6.1.1	Properties .....	16
1.4	Symbols used .....	4	6.1.2	Eco mode .....	16
<b>2</b>	<b>Safety notes</b> .....	<b>4</b>	6.1.3	Launching test mode .....	17
<b>3</b>	<b>Device description</b> .....	<b>5</b>	6.1.4	General information about programming ..	17
3.1	TÜV-tested output measurement to DIN EN 14511 .....	5	6.1.5	Editable parameters .....	18
3.2	Functional description .....	5	6.1.6	Programming overview .....	19
3.2.1	How it works .....	5	6.1.7	Defining system messages for evaluation ..	20
3.2.2	Control .....	5	6.1.8	Setting the master/slave identifier .....	21
3.2.3	Bus mode (e-Comfort controller only) .....	6	6.1.9	Evaluating system messages .....	21
3.2.4	Safety devices .....	6	6.1.10	Resetting the e-Comfort controller .....	23
3.2.5	Condensation .....	6	<b>7</b>	<b>Inspection and maintenance</b> .....	<b>23</b>
3.2.6	Filter mats .....	6	7.1	Compressed air cleaning .....	23
3.2.7	Door limit switch .....	6	<b>8</b>	<b>Storage and disposal</b> .....	<b>25</b>
3.2.8	Additional interface X3 .....	7	<b>9</b>	<b>Technical details</b> .....	<b>26</b>
3.3	Proper use .....	7	9.1	Technical specifications .....	26
3.4	Scope of supply .....	7	9.2	Performance diagrams .....	29
<b>4</b>	<b>Assembly and connection</b> .....	<b>7</b>	9.2.1	Single-phase by output category .....	29
4.1	Choosing the installation site .....	7	9.2.2	3-phase by output category .....	31
4.2	Notes on assembly .....	7	<b>10</b>	<b>List of spare parts</b> .....	<b>32</b>
4.2.1	General .....	7	<b>11</b>	<b>Appendix:</b>	
4.2.2	Layout of the electronic components in the enclosure .....	8		<b>Cut-out and hole sizes</b> .....	<b>34</b>
4.3	Fitting the cooling unit .....	8	11.1	Dimensions for assembly .....	34
4.3.1	Making the cut-outs .....	9			
4.3.2	Top mounting of the cooling unit .....	9			
4.4	Connecting the condensate discharge .....	9			
4.5	Notes on electrical installation .....	10			
4.5.1	Connection data .....	10			
4.5.2	Overvoltage protection and supply line load .....	10			
4.5.3	Three-phase devices .....	10			
4.5.4	Door limit switch .....	11			
4.5.5	Notes on the flicker standard .....	11			
4.5.6	Potential equalisation .....	11			
4.6	Making the electrical connection .....	11			
4.6.1	Bus connection (only when interconnecting several units with an e-Comfort controller) .....	11			
4.6.2	Connection X3 for serial interface .....	11			
4.6.3	Installing the power supply .....	13			
4.7	Finalising assembly .....	15			
4.7.1	Installing the filter media .....	15			
4.7.2	Fitting the cooling unit .....	15			
4.7.3	Setting the filter mat monitor .....	15			

# 1 Notes on documentation

## 1 Notes on documentation

These assembly instructions are aimed at

- tradespersons who are familiar with assembly and installation of the cooling unit
- trained specialists who are familiar with operation of the cooling unit

### 1.1 Associated documents

Assembly and operating instructions exist as paper documents and/or on CD-ROM for the unit types described here and are enclosed with the equipment. We cannot accept any liability for damage associated with failure to observe these instructions. Where applicable, the instructions for any accessories used also apply.

### 1.2 CE labelling

The declaration of conformity is supplied with the unit as a separate document.

### 1.3 Retention of documents

These instructions and all associated documents constitute an integral part of the product. They must be given to the plant operator. The operator is responsible for storage of the documents so they are readily available when needed.

### 1.4 Symbols used

- 
- **The bullet point indicates an action to be performed.**
- 



**Danger!**  
**Immediate danger to life and limb!**

---



**Caution!**  
**Potential threat to the product and the environment.**

---



**Note:**  
Useful information and special features.

---

## 2 Safety notes

Please observe the following general safety notes when assembling and operating the unit:

- Assembly, installation and servicing may only be performed by properly trained specialists.
- Do not obstruct the air inlet and air outlet of the cooling unit inside and outside the enclosure (see section 4.2.2).
- The heat loss of the components installed in the enclosure must not exceed the specific useful cooling power of the cooling unit.
- The cooling unit must always be transported in a horizontal position.
- Use only original spare parts and accessories.
- Do not make any changes to the cooling unit other than those described in these instructions or associated instructions.
- Risk of burns! On cooling units with automatic condensate evaporation, the surface of the thermal element will get very hot during operation, and will remain so for some time afterwards.
- The mains connector of the cooling unit must only be connected and disconnected with the system de-energised. Connect the pre-fuse specified on the rating plate.

## 3 Device description

Depending on the model chosen, your cooling unit may vary in appearance from the illustrations contained in these instructions. However, the functions are identical in principle.

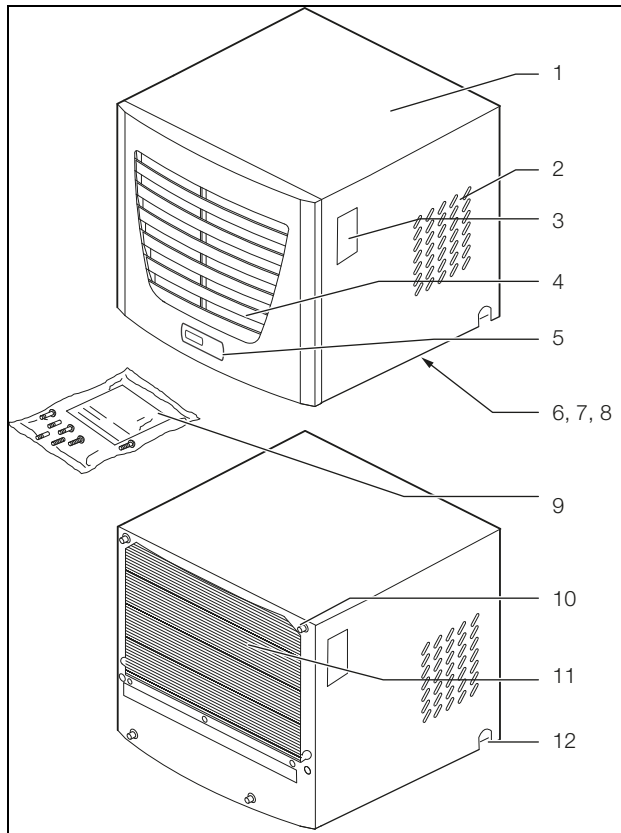

Fig. 1: Device description

### Key

- 1 Enclosure
- 2 Air outlet holes
- 3 Rating plate
- 4 Louvred grille for air inlet
- 5 Display
- 6 X2 master-slave connection (underside of the unit)
- 7 X1 terminal strip (underside of the unit)
- 8 X3 optional serial interface (underside of the unit)
- 9 Dispatch bag
- 10 Twin-threaded bolt
- 11 Condenser
- 12 Condensate discharge

### 3.1 TÜV-tested output measurement to DIN EN 14511

All TopTherm cooling units in the output range from 300 to 4000 W are tested to the latest EN 14511:2012-01 standard by independent test institute TÜV Nord. This means you have peace of mind about the design of the climate control solution and you can be sure you are getting the performance you are paying for.

## 3.2 Functional description

Enclosure cooling units are designed to dissipate heat from enclosures by cooling the air inside the enclosure and so protect the temperature-sensitive components. It is mounted on the roof of an enclosure.

### 3.2.1 How it works

The cooling unit (compression refrigeration system) comprises four main components (see fig. 2): the evaporator (1), the refrigerant compressor (2), the condenser (3), and the control or expansion valve (4), which are connected by suitable pipework. This circuit is filled with a readily boiling substance, the refrigerant. The refrigerant R134a ( $\text{CH}_2\text{FCF}_3$ ) is chlorine-free. Its Ozone Depletion Potential (ODP) is 0, making it very eco-friendly. A filter dryer (5) which is integrated into the hermetically sealed cooling circuit provides effective protection against moisture, acid, dirt particles, and foreign bodies within the cooling circuit.

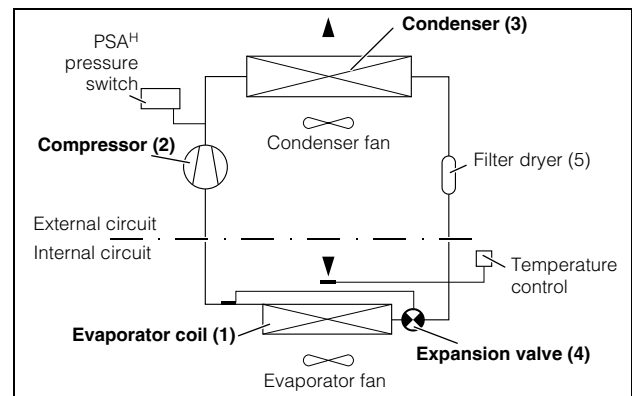

Fig. 2: Cooling circuit

In the evaporator coil (1), the liquid refrigerant is converted to a gaseous state. The energy needed for this purpose is taken from the enclosure air in the form of heat, which has the effect of cooling the enclosure air. In the compressor (2), the refrigerant is heavily compressed, so that it achieves a higher temperature inside the condenser (3) than the ambient air. This means that excess heat may be emitted to the ambient air via the surface of the condenser, as a result of which the temperature of the refrigerant drops and it is converted back into liquid. It is re-injected into the evaporator coil via a thermostatic expansion valve (4), which causes it to cool down further, and is then once again able to absorb the energy from the enclosure air in the evaporator coil. The whole cycle begins again.

### 3.2.2 Control

Rittal enclosure cooling units are fitted with a controller for setting the functions of the cooling unit (display plus extended functions, see chapter "6 Operation", page 16).

## 3 Device description

EN

### 3.2.3 Bus mode (e-Comfort controller only)

The serial unit interface X2 allows you to create a bus connection with up to ten cooling units using the master-slave cable (shielded, four-wire cable, Model No. 3124.100). This allows you to implement the following functions:

- Parallel unit control (the cooling units in the network can be switched on and off simultaneously)
- Parallel door status message (“door open”)
- Parallel collective fault message

Data is exchanged via the master-slave connection. During commissioning, assign an address to each unit that also includes the identifier “master” or “slave”.

### 3.2.4 Safety devices

- In the cooling cycle, the cooling unit has a tested pressure switch to EN 12 263 which is set to maximum PS (permissible pressure); this operates via an automatic reset device whenever the pressure drops again.
- Temperature monitoring prevents the evaporator coil from icing over. If there is a risk of icing, the compressor switches itself off and automatically switches itself back on again at higher temperatures.
- The refrigerant compressor and the fans are equipped with thermal winding shields to protect against excess current and excess temperatures.
- In order to allow a reduction of pressure inside the compressor and hence a safe restart, once it has been switched off (e.g. upon reaching the set temperature via the door limit switch function or via de-energising), the device will switch back on with a delay of 180 seconds.
- The device has floating contacts on the connection pins (terminals 3 – 5), via which system messages from the device may be polled, e.g. using a PLC (2x normally open contacts, e-Comfort controller).

### 3.2.5 Condensation

At high levels of humidity and low temperatures inside the enclosure, condensation may form on the evaporator coil.

The cooling units have an automatic electrical condensate evaporator. The thermal component used for this purpose is based on self-regulating PTC technology. Condensate arising on the evaporator coil is collected in a tank in the internal circuit of the cooling unit. When the water level rises, the water enters the PTC thermal component and is evaporated (through-flow heater principle). The water vapour streams out of the cooling unit with the airflow from the external fan.

The PTC thermal component is permanently connected and has no switchpoint. It is protected against short-circuits with miniature fuses (F1.1, F1.2). If the fuse has tripped, any condensation is drained off via the safety overflow.

In the case of a malfunction or a failure in the thermal component, the condensation water is routed out of the unit via a drain pipe at the side or rear for safety reasons. For this purpose, a hose must be connected to the condensate nozzle (see “4.4 Connecting the condensate discharge”, page 9). Condensate hoses are available as accessories (refer also to the accessories section in the Rittal Catalogue).

### 3.2.6 Filter mats

The entire cooling unit condenser is covered with a dirt-repelling, easy-to-clean RiNano coating. In many applications, therefore, the use of filter media is unnecessary, particularly with dry dusts.

For dry, coarse dust and lint in the ambient air, we recommend installing an additional PU foam filter mat (available as an accessory) in the cooling unit. Depending on the incidence of dust, you will need to replace the filter mat from time to time.

For air containing oil condensate, we recommend the use of metal filters (also available as an accessory). These may be cleaned with suitable detergents and reused. When used in textile plants with heavy lint contamination, lint screens should be used (available as an optional extra).

Function of the filter mat monitor (with e-Comfort controller only):

Dirt on the filter mat is automatically determined by measuring the temperature difference in the external circuit of the cooling unit. As the level of filter mat soiling increases, the temperature difference will increase. The setpoint value of the temperature difference in the external circuit adapts automatically to the relevant operating points in the performance diagrams. Hence there is no need to readjust the setpoint value for different unit operating points.

### 3.2.7 Door limit switch

The cooling unit may be operated with a floating door limit switch connected. The door limit switch is not included with the supply (available as an accessory, Model No. 4127.010).

The door limit switch function causes the fans and the compressor in the cooling unit to be switched off after approximately 15 seconds when the enclosure door is opened (contacts 1 and 2 closed). This prevents the formation of condensation inside the enclosure while the enclosure door is open. In order to prevent damage to the unit, it is equipped with an ON delay: The evaporator fan cuts back in with a delay of approximately 15 seconds after the door has been closed, while the condenser fan and compressor switch on after approximately 3 minutes.



#### Note:

No external voltage may be applied to the door contacts (terminals 1 and 2).

## 3.2.8 Additional interface X3



**Note:**

The electrical signals at the interface are of an extra-low voltage (not extra-low safety voltages to EN 60 335).

An additional interface card may be connected to the 9-pole SUB-D connector X3 in order to incorporate the cooling unit into higher-level monitoring systems (available as an accessory, interface card Model No. 3124.200).

## 3.3 Proper use

Rittal enclosure cooling units were developed and designed in accordance with the state of the art and the recognised rules governing technical safety. Nevertheless, if used improperly, they may pose a threat to life and limb or cause damage to property. The unit is only intended for cooling enclosures. Any other use is deemed improper. The manufacturer will not be liable for any damages caused as a result of improper use, or for incorrect assembly, installation or use. All risk is borne solely by the user.

Proper usage also includes the observation of all valid documents and compliance with the inspection and servicing conditions.

## 3.4 Scope of supply

The unit is supplied in a packaging unit in a fully assembled state.

Please check the scope of supply for completeness.

Qty.	Description
1	Enclosure cooling unit
1	Dispatch bag:
1	– Sealing plate (3273.xxx, 3383.xxx, 3384.xxx, 3385.xxx)
1	– Sealing frame
1	– Plug-in terminal strip
1	– Assembly and installation instructions
1	– Assembly, installation and operating instructions on CD-ROM
1	– Declaration of conformity
1	– Safety notes
3	Blind rivet (3386.xxx, 3387.xxx)
1	Drilling template

Tab. 1: Scope of supply

## 4 Assembly and connection

### 4.1 Choosing the installation site

When choosing the installation site for the enclosure, please observe the following:

- The site for the enclosure and the positioning of the cooling unit must be carefully selected so as to ensure good ventilation. Depending on the siting of the unit, if several units are installed directly adjacent to one another, the distance from the wall must be at least 200 mm.
- The cooling unit must be installed and operated in a horizontal position (maximum deviation: 2°).
- The site must be free from excessive dirt and moisture.
- The ambient temperature must not exceed 55°C.
- It must be possible to fit a condensate discharge (see “4.4 Connecting the condensate discharge”, page 9).
- The mains connection data as stated on the rating plate of the unit must be guaranteed.

### 4.2 Notes on assembly

#### 4.2.1 General

- Check the packaging carefully for signs of damage. Traces of oil on damaged packaging are an indication of refrigerant loss and leakages. Any packaging damage may be the cause of a subsequent functional failure.
- The enclosure must be sealed on all sides (IP 54). Increased condensation will occur if the enclosure is not airtight.
- In order to avoid excessive condensation inside the enclosure, we recommend installing a door limit switch (e.g. 4127.010) which deactivates the cooling unit when the enclosure door is opened (see “3.2.7 Door limit switch”, page 6).

# 4 Assembly and connection

## 4.2.2 Layout of the electronic components in the enclosure



### Caution!

#### Risk of condensation!

When arranging the components inside the enclosure, please ensure that the cold airflow from the cooling unit is not directed at active components. Please also ensure that the cold airflow is not directed at the warm exhaust airflow from active components such as converters. This may lead to an air short-circuit and therefore prevent adequate climate control, or may even cause the cooling unit's internal safety devices to cease cooling operation.

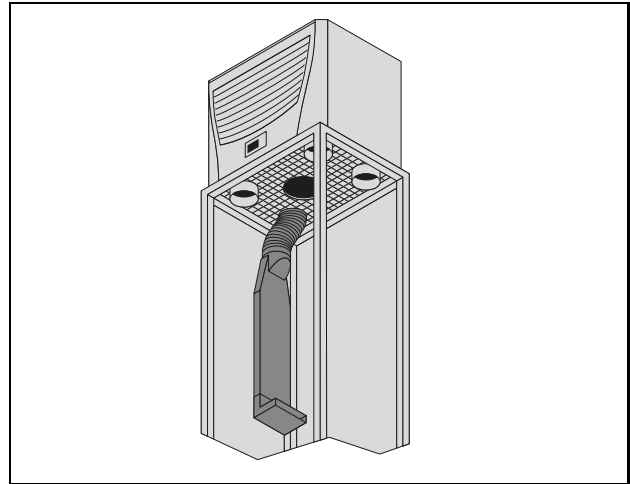

Fig. 4: Targeted air routing inside the enclosure

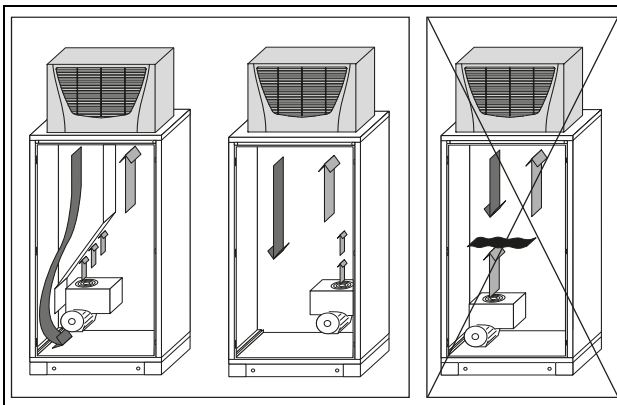

Fig. 3: Never direct the cold airflow at active components

Exercise particular caution with the airflow from the blowers of built-in electronic components (see fig. 3). Components for targeted air routing are available as accessories – please refer to the Rittal Catalogue.



### Note:

When using an air duct system, care must be taken to ensure that it is laid straight and without kinks wherever possible. This minimises the resistance to the cold airflow. It is important to ensure even air circulation inside the enclosure. Under no circumstances should air inlet and outlet openings be obstructed, otherwise the cooling performance of the unit will be reduced. Ensure a suitable distance from electronic components and other installed enclosures so that the required air circulation is not obstructed and prevented. One cold air outlet from the cooling unit must be kept open at all times when operating with the air duct, to prevent the accumulation of cold air inside the unit.



### Note:

When using the cover bungs, only a maximum of 1 or 2 cold air outlet openings may be sealed, depending on the unit type.

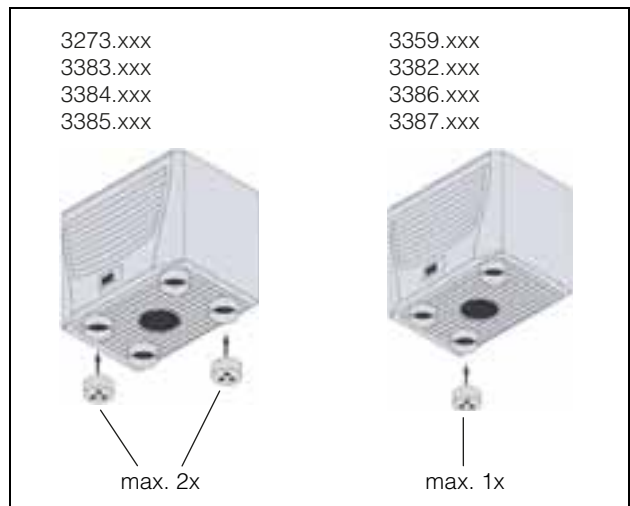

Fig. 5: Cover bungs

## 4.3 Fitting the cooling unit

The enclosure cooling unit is mounted on top of the enclosure roof:

To this end, cut-outs must be made in the roof plate as per the drilling template included with the supply.



### Note:

Pre-configured, reinforced roof plates with cut-outs to match your enclosure are available as accessories; refer to the Rittal Catalogue.



## 4.3.1 Making the cut-outs

- Affix the supplied drilling template to the roof of the enclosure using adhesive tape.

There are dimensioning lines on the drilling template to suit the installation type for your cooling unit.



**Risk of injury!**  
Carefully deburr all cut-outs to prevent injuries caused by sharp edges.

- Make the cut-outs including the line width as per the drilling template.
- Deburr the cut-outs.

## 4.3.2 Top mounting of the cooling unit

- Affix the supplied sealing frame onto the cut out roof plate.

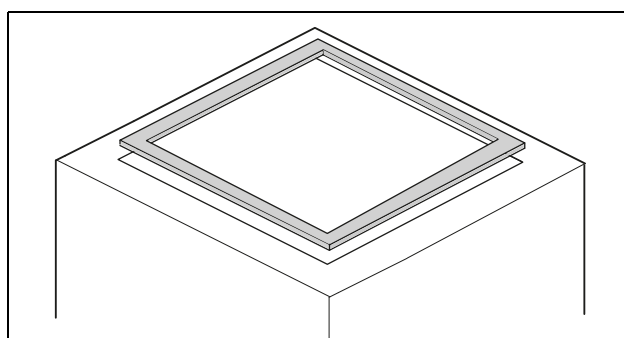

Fig. 6: Sealing frame on roof plate

- Affix the supplied sealing plate to the bottom of the plastic base of the cooling unit (3273.xxx, 3383.xxx, 3384.xxx, 3385.xxx).

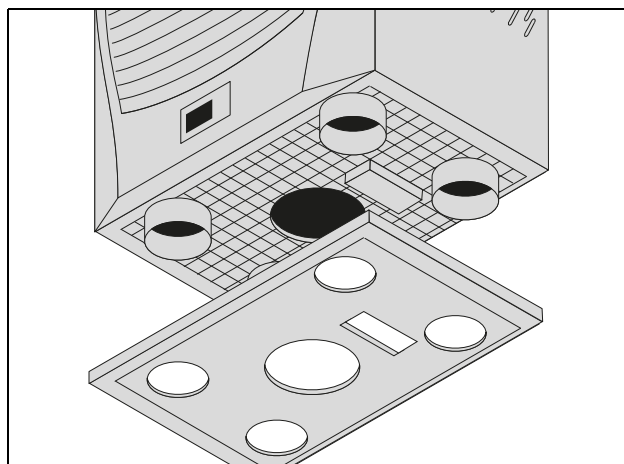

Fig. 7: Sealing plate underneath the plastic base of the cooling unit

- Mount the cooling unit on the enclosure roof.
- Screw the supplied twin-threaded bolts into the core holes in the plastic base on the underside of the cooling unit with a maximum of 5 Nm.
- Secure the unit using the supplied washers and nuts.



### Note:

In order to achieve a permanent seal between the cooling unit and the enclosure, the mounting surface should be reinforced or supported if necessary. This is particularly applicable with large roof areas.

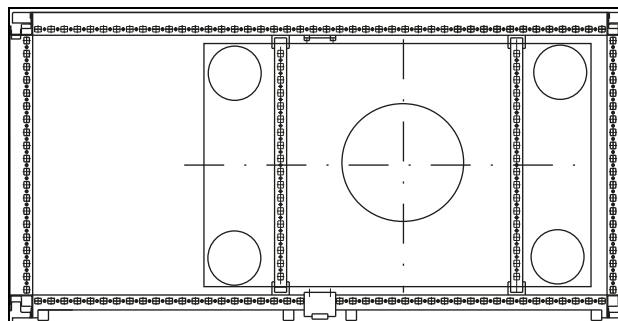

Fig. 8: Roof plate reinforcement for the TS 8 enclosure

### Accessories for roof plate reinforcement with TS:

- TS roof plates
  - Quick-change frame
  - Punched rail
  - U nut
  - Fastening bracket
  - Threaded block
- (refer also to Accessories in the Rittal Catalogue)

## 4.4 Connecting the condensate discharge

A condensate discharge hose ( $\varnothing 1/2"$ ) may be fitted to the cooling unit.

The condensate discharge

- must be laid with a suitable and constant gradient (no siphoning)
  - must be laid without kinks
  - must not have a reduced cross-section if extended
- The condensate hose is available as an accessory (refer also to Accessories in the Rittal Catalogue).

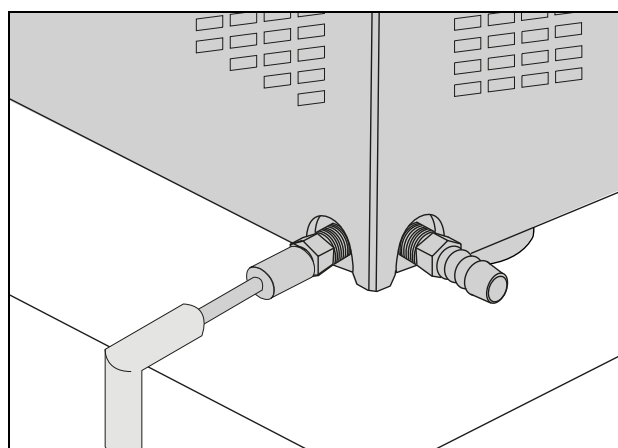

Fig. 9: Connecting the condensate discharge

- Connect a suitable hose to one of the two condensate nozzles and secure using a hose clip. The condensate nozzle that is not required should be sealed.
- Lay the condensate hose, e.g. into a drain.

## 4 Assembly and connection

EN

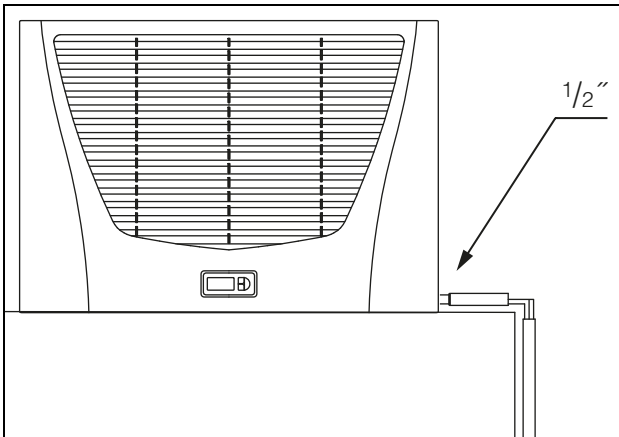

Fig. 10: Laying the condensate discharge

### 4.5 Notes on electrical installation

When performing the electrical installation, it is important to observe all valid national and regional regulations as well as the provisions of the responsible power supply company. The electrical installation may only be carried out by a qualified electrician who is responsible for compliance with the applicable standards and regulations.

#### 4.5.1 Connection data

- The connected voltage and frequency must correspond to the values stated on the rating plate.
- The cooling unit must be connected to the mains via an all-pin isolating device, which ensures at least 3 mm contact opening when switched off.
- No additional temperature control may be connected upstream of the unit at the supply end.
- Install the pre-fuse specified on the rating plate to protect the cable and equipment from short-circuits.
- The mains connection must ensure low-noise potential equalisation.

#### 4.5.2 Overvoltage protection and supply line load

- The unit does not have its own overvoltage protection. Measures must be taken by the operator at the supply end to ensure effective lightning and overvoltage protection. The mains voltage must not exceed a tolerance of  $\pm 10\%$ .
- In accordance with IEC 61 000-3-11, the unit is intended solely for use at sites with a continuous current-carrying capacity (incoming mains power supply) of more than 100 A per phase and with a supply voltage of 400/230 V. If necessary, the power supply company must be consulted to ensure that the continuous current-carrying capacity at the point of connection to the public grid is sufficient for connection of such a unit.
- The fans and compressors in single- and three-phase units are intrinsically safe (thermal winding protection). The same also applies to all transformer versions and to special-voltage units which are likewise equipped with a transformer.
- Install the slow pre-fuse specified on the rating plate (miniature circuit-breaker with appropriate characteristic – e.g. “K” characteristic – or gG standard type slow fuse, circuit-breaker for plant or transformer protection) to protect the cable and equipment from short-circuits. Select a suitable circuit-breaker in accordance with the information specified on the rating plate: Set it to the minimum specified value. This will achieve the best short-circuit protection for cables and equipment. Example: Specified setting range 6.3 – 10 A; set to 6.3 A.

#### 4.5.3 Three-phase devices

- The electrical connection for devices in the three-phase version **MUST** be made with a clockwise rotating field.
- The three-phase version must be connected to a TN network with star earthing via a circuit-breaker for plant protection (current setting as per the rating plate). Three-phase units with special voltages must be protected with a circuit-breaker for transformer protection (category AC-3) as per the rating plate.
- Units designed for three phase 400/460 V feature additional monitoring of the rotary field or the absence of a phase. If the rotary field is incorrect or a phase is absent, the unit will not run.

### 4.5.4 Door limit switch

- Each door limit switch must only be assigned to one cooling unit.
- Several door limit switches may be connected in parallel to one cooling unit.
- The minimum cross-section for the connection cable is 0.3 mm<sup>2</sup> for a cable length of 2 m. We recommend the use of a shielded cable.
- The line resistance to the door limit switch must not exceed a maximum of 50 Ω.
- The door limit switch only supports a floating connection; no external voltages.
- The contact of the door limit switch must be closed when the door is open.

The safety extra-low voltage for the door limit switch is provided by the internal power pack: Current approx. 30 mA DC.

- Connect the door limit switch to terminals 1 and 2 of the connector.

### 4.5.5 Notes on the flicker standard

The flicker limits specified in standard EN 61 000-3 -3 or -3-11 are adhered to, provided the supply impedance is less than approx. 1.5 Ω.

Where necessary, the unit operator should measure the connected impedance or consult the responsible power supply company. If there is no way of influencing the supply impedance and sensitive installed components (e.g. BUS) are subjected to interference, a line reactor or starting-current limiting device should be connected upstream of the cooling unit to restrict the startup current of the cooling unit.

### 4.5.6 Potential equalisation

If, for EMC reasons, the unit is to be integrated into the customer's existing potential equalisation system, a conductor with a larger nominal cross-section can be connected to the potential equalisation connection point (attachment points) on the roof-mounted cooling units.

According to the standard, the PE conductor in the mains connection cable is not classified as an equipotential bonding conductor.

## 4.6 Making the electrical connection

### 4.6.1 Bus connection (only when interconnecting several units with a Comfort controller)

When using several cooling units, the serial device interface X2 can be used to connect up to ten cooling units with the bus cable (Model No. 3124.100).



#### Note:

The electrical signals at the X2 interface are of an extra-low voltage (not extra-low safety voltages in accordance with EN 60 335-1).

When interconnecting, please note the following:

- De-energise the cooling units to be connected
- Ensure proper electrical insulation
- Make sure the cables are not laid in parallel to power lines
- Make sure that the lines are short



#### Caution!

**With the last slave unit in the group, do not, under any circumstances, connect the remaining socket of the Y cable 3124.100 into interface X3 of the cooling unit!**

### 4.6.2 Connection X3 for serial interface

The interface card (Model No. 3124.200) may be connected to X3. This is used to evaluate system messages in a PLC, for remotely setting parameters and monitoring, or for integration into the facility management system.

# 4 Assembly and connection

EN

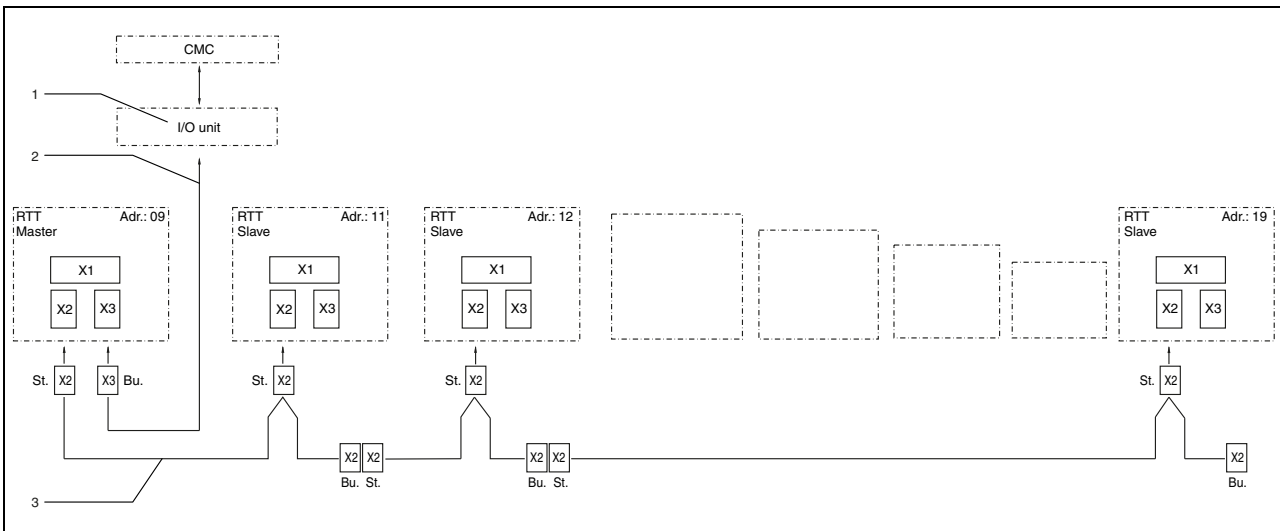

Fig. 11: Connection example: Master-slave operation

### Key

- |     |                                             |      |                                       |
|-----|---------------------------------------------|------|---------------------------------------|
| 1   | Serial interface (Model No. 3124.200)       | X2   | Master/slave connection Sub-D, 9-pole |
| 2   | Serial interface cable                      | X3   | Serial interface Sub-D, 9-pole        |
| 3   | Master-slave bus cable (Model No. 3124.100) | St.  | Sub-D connector, 9-pole               |
| RTT | Rittal TopTherm cooling units               | Bu.  | Sub-D jack, 9-pole                    |
| X1  | Supply connection/door limit switch/alarms  | Adr. | Address                               |

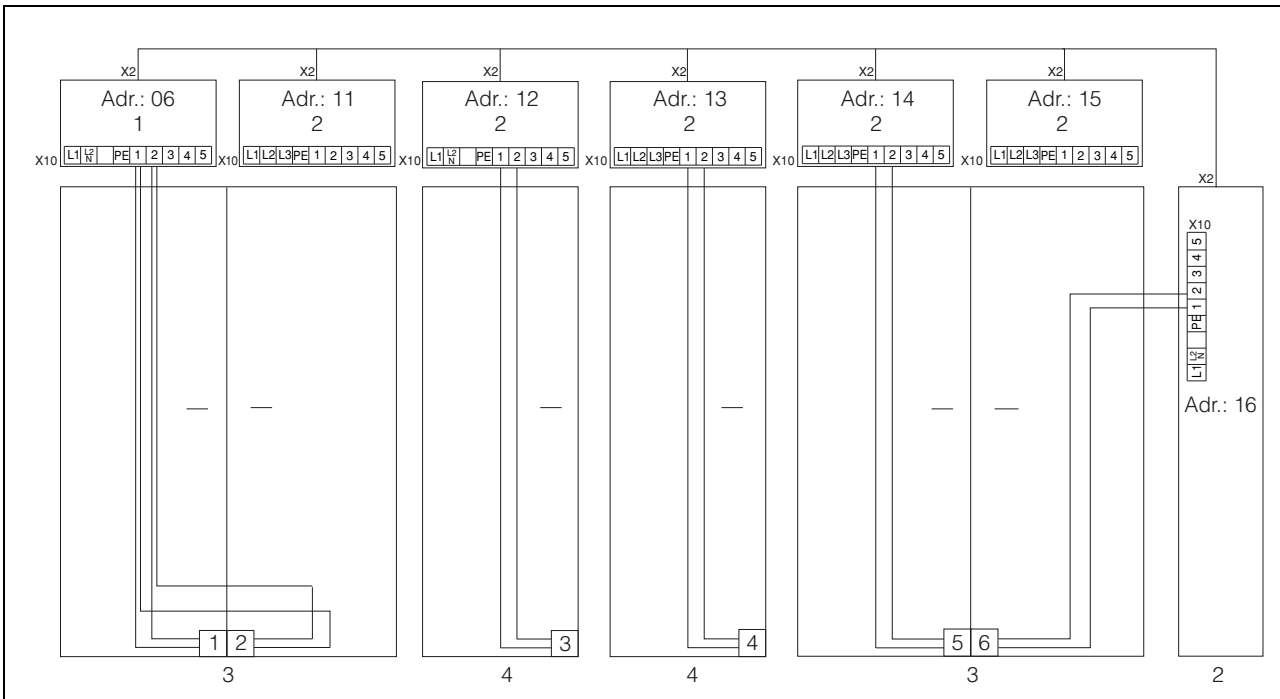

Fig. 12: Connection example: Door limit switch and master-slave operation

### Key

- |   |                                               |
|---|-----------------------------------------------|
| 1 | Master cooling unit                           |
| 2 | Slave cooling units                           |
| 3 | 2-door enclosure with two door limit switches |
| 4 | Enclosure with door limit switch              |

## 4.6.3 Installing the power supply

■ Complete the electrical installation as per the wiring plan inside the cooling unit underneath the cable shaft cover (see fig. 29 on page 24, marked with an arrow).

■ If you would like the system messages from the cooling unit to be evaluated via the system message relay, you should also connect a suitable low-voltage cable to connection pins 3 – 5.

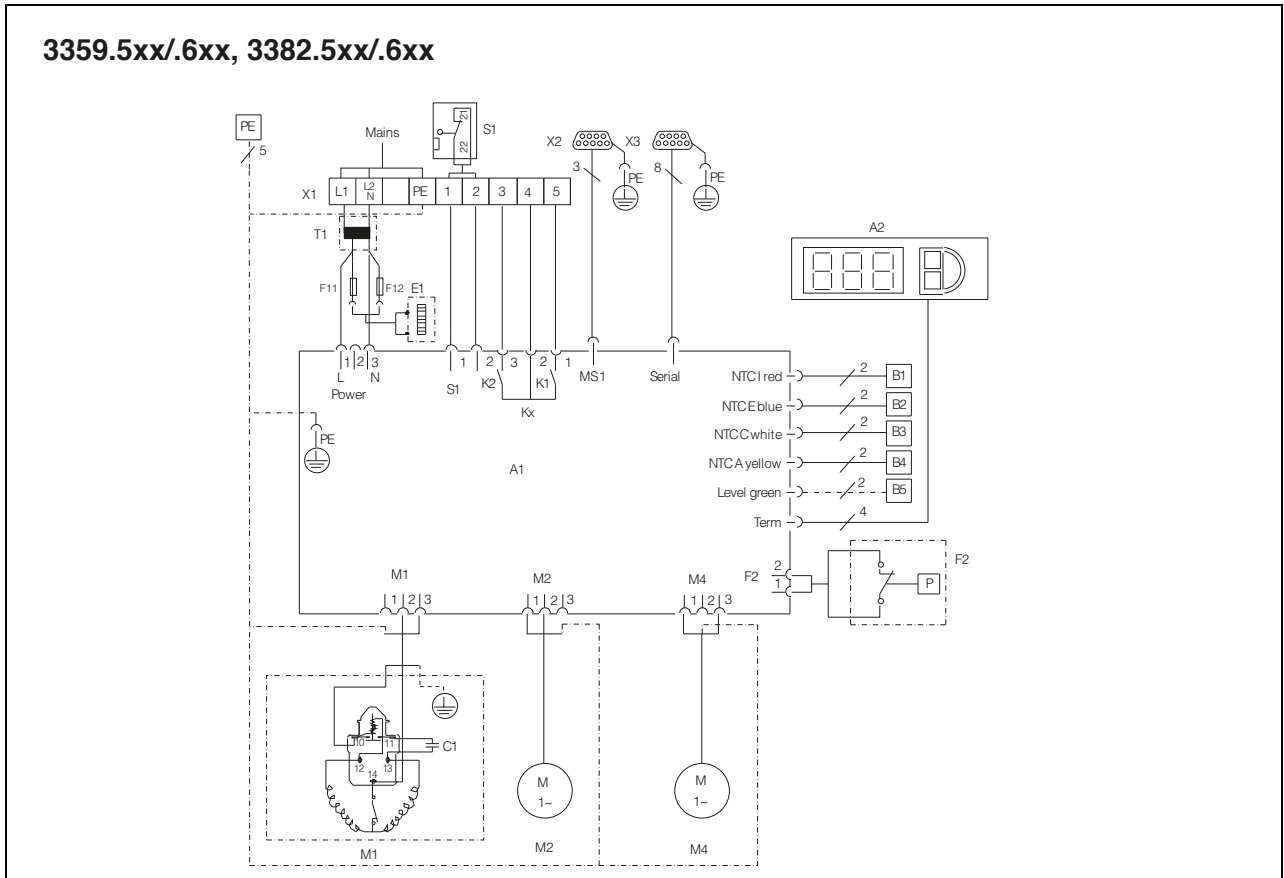

Fig. 13: Electrical wiring plan no. 1

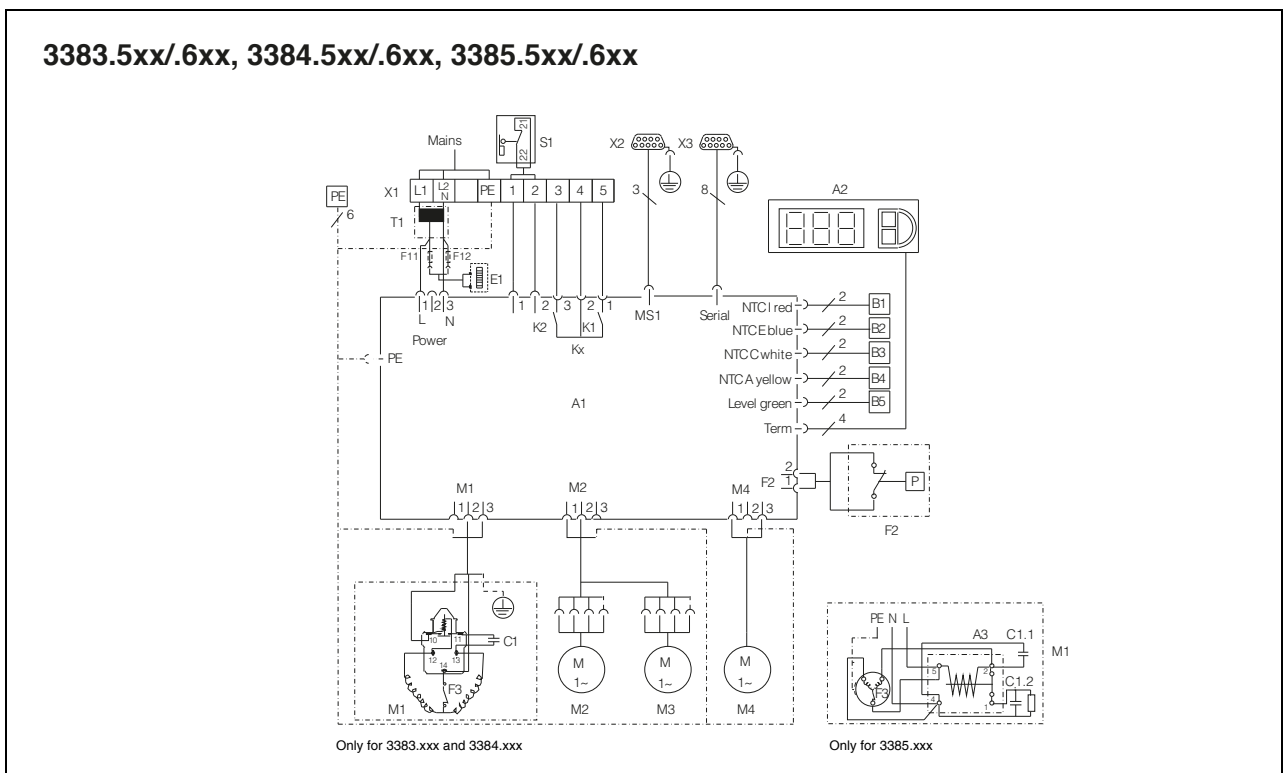

Fig. 14: Electrical wiring plan no. 2

# 4 Assembly and connection

EN

## 3386.54x/.64x, 3387.54x/.64x

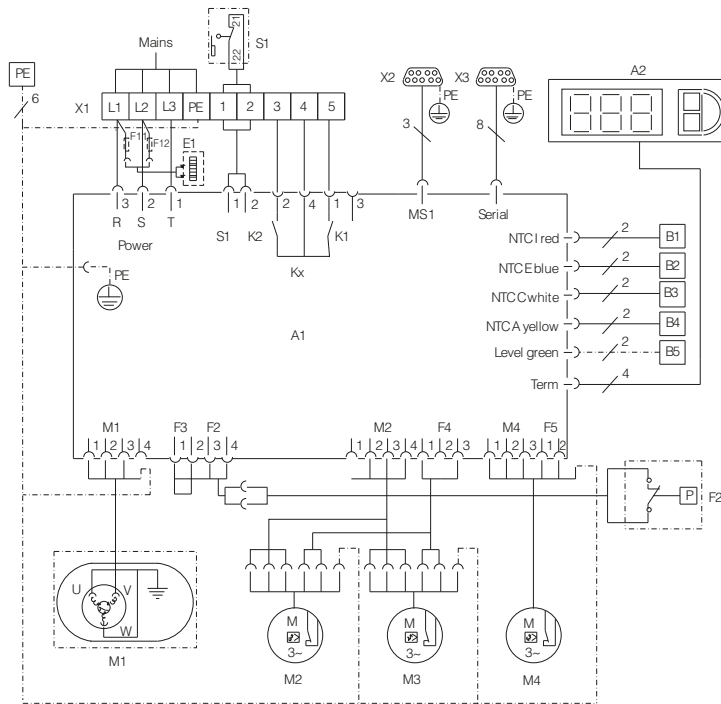

Fig. 15: Electrical wiring plan no. 3

### Key

- A1 Power PCB
- A2 Display terminal
- A3 Starter relay and RC element
- B1 Temperature sensor, internal temperature
- B2 Icing hazard temperature sensor
- B3 Condenser temperature sensor
- B4 Ambient temperature sensor
- B5 Condensate warning sensor (optional)
- C1 Start-up capacitor (3383.xxx/3384.xxx)
- C1.1 Operating capacitor (3385.xxx)
- C1.2 Start-up capacitor (3385.xxx)
- E1 Condensate evaporator
- F2 PSA<sup>H</sup> pressure switch
- F3 Compressor thermal contact
- F11/F12 Miniature fuses, condensate evaporator
- K1 Relay collective fault 1
- K2 Relay collective fault 2
- M1 Compressor
- M2 Condenser fan
- M3 Condenser fan (optional)  
(3383.xxx to 3387.xxx)
- M4 Evaporator fan
- S1 Door limit switch  
(without door limit switch: terminal 1, 2 open)
- T1 Transformer (optional)
- X1 Main terminal strip
- X2 Master/slave connection
- X3 Optional interface



### Note:

For technical data, refer to the rating plate.

AC cos f = 1	DC L/R = 20 ms
I max. = 2 A U max. = 250 V	I min. = 100 mA U max. = 200 V U min. = 18 V I max. = 2 A

Tab. 2: Contact data

## 4.7 Finalising assembly

### 4.7.1 Installing the filter media

The entire cooling unit condenser is covered with a dirt-repelling, easy-to-clean RiNano coating. In many applications, therefore, the use of filter media is unnecessary, particularly with dry dusts.

For dry, coarse dust and lint in the ambient air, we recommend installing an additional PU foam filter mat (available as an accessory) in the cooling unit. For air containing oil condensate, we recommend the use of metal filters (also available as an accessory). When used in textile plants with heavy lint contamination, lint screens should be used (available as an optional extra).

- Pull the louvred air inlet grille off the enclosure.
- Secure the filter mat in front of the condenser using the supplied blind rivets.
- Then push the louvred grille back onto the enclosure.

### 4.7.2 Fitting the cooling unit

- Connect the connector to the rear of the display.
- Place the louvred grille onto the unit at the front, and press it down until you hear it snap into place.

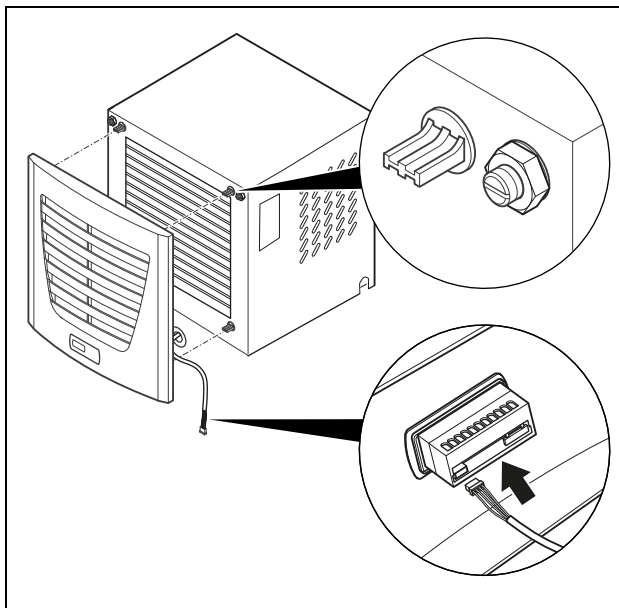

Fig. 16: Connect the display and attach the louvred grille

### 4.7.3 Setting the filter mat monitor

Function of the filter mat monitor:

Dirt on the filter mat is automatically detected by measuring the temperature difference in the external circuit of the cooling unit (see “6.1.6 Programming overview”, page 19). As the level of filter mat soiling increases, the temperature difference will increase. The setpoint value of the temperature difference in the external circuit adapts automatically to the relevant operating points in the performance diagrams. Hence there is no need to readjust the setpoint value for different unit operating points.

## 5 Start-up



### Caution! Risk of damage!

**The oil must be collected in the compressor in order to ensure effective lubrication and cooling.**

**Do not operate the cooling unit for at least 30 minutes after assembling the equipment.**

- Once all the assembly and installation work is complete, switch on the power supply to the cooling unit.

The cooling unit starts running:

- The software version of the controller first appears for approx. 2 seconds, then “ECO” to show Eco mode is enabled. The internal enclosure temperature will then appear in the 7-segment display.

You can now make your individual settings on the unit e.g. set the temperature or assign the network identifier etc. (refer to chapter “6 Operation”).

# 6 Operation

## 6 Operation

You can operate the cooling unit using the controller on the front of the device (fig. 1, no. 5, page 5).

### 6.1 Control using the e-Comfort controller

For unit types xxxx.500/.510/.540 and xxxx.600/.610/.640.

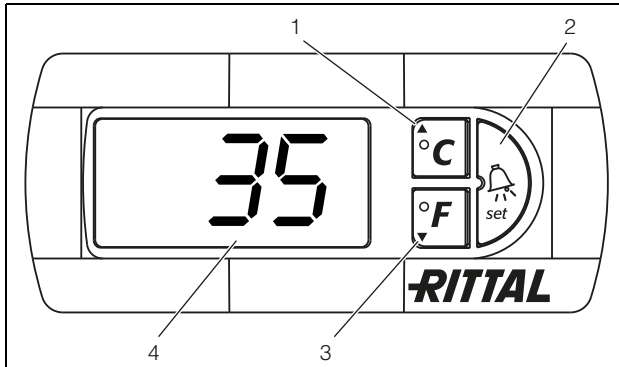

Fig. 17: e-Comfort controller

#### Key

- 1 Programming button, also display of the set temperature unit (degrees Celsius)
- 2 Set button
- 3 Programming button, also display of the set temperature unit (degrees Fahrenheit)
- 4 7-segment display

#### 6.1.1 Properties

- Rated operating voltage:
  - 115 V or
  - 230 V or
  - 400 V, 2-phase or
  - 400/460 V, 3-phase
- Integral start-up delay and door limit switch function.
- Protective function to prevent icing.
- Monitoring of all motors (compressor, condenser fan, evaporator fan).
- Phase monitoring for three-phase units.
- Master-slave function with a maximum of ten units. One device functions as a master unit. Once the set temperature is reached by one of the connected slave devices or in the event of the door limit switch function, the affected slave unit will report to the master unit that switches all the other cooling units on or off as required.
- Switching hysteresis: adjustable within the range 2 – 10 K, preset to 5 K.
- Visualisation of the current internal enclosure temperature and all error messages in the 7-segment display.
- Using an interface card (Model No. 3124.100), the unit may be incorporated into higher-level remote monitoring systems such as the Rittal Computer Multi Control CMC.

The cooling unit operates automatically, i.e. after switching on the power supply, the evaporator fan (see fig. 2, page 5) will run and circulate the internal enclosure air.

The compressor and condenser fan are regulated by the e-Comfort controller.

The e-Comfort controller has a 7-segment display (fig. 17, no. 4). After switching on the power supply, the current software version initially appears on this display for approx. 2 seconds together with the symbol to show Eco mode is enabled, followed by a preset option (e.g. t10) or the temperature. In regular operation, the display shows both the temperature (in degrees Celsius or Fahrenheit – users may switch between the two) and any error messages.

The current internal enclosure temperature is usually displayed permanently. In the event of an error message, this alternates with the temperature display.

The unit is programmed using buttons 1 – 3 (fig. 17). The relevant parameters also appear in the display.

#### 6.1.2 Eco mode

All Rittal TopTherm cooling units with e-Comfort controller from firmware 3.2 have the energy-saving eco mode, which is enabled in the delivered state. The eco mode is used to save energy in the heat exchanger if there is no thermal load, or there is a low thermal load in the enclosure (e.g. standby operation, no production or weekend).

During this process the evaporator fan in the internal circuit is switched off as appropriate if the actual internal enclosure temperature drops to 10 K below the specified setpoint temperature. To ensure the internal temperature is reliably measured during this process, the fan starts cyclically for 30 sec. every 10 minutes (see fig. 18). If the internal temperature drops to a range 5 K below the setpoint set again, the fan switches back to continuous operation.

If required, eco mode can be disabled on the control display. For this purpose switch the parameter from 1 to 0 in the programming level (see tab. 3, page 18). The fan then runs continuously.

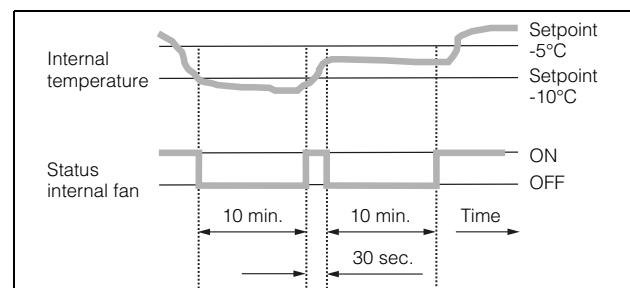

Fig. 18: Eco mode



### 6.1.3 Launching test mode

The e-Comfort controller is equipped with a test function whereby the cooling unit commences cooling operation independently of the set temperature or door limit switch function.

- Simultaneously press buttons 1 and 2 (fig. 17) for at least five seconds.

The cooling unit will commence operation.

Test mode is completed after approximately 5 minutes. The unit switches off and changes to normal operation.

### 6.1.4 General information about programming

Using buttons 1, 2 and 3 (fig. 17) you can change 24 parameters within the preset ranges (min. value – max. value).

Tables 3 and 4 show the parameters which can be altered. Fig. 20 on page 19 shows which buttons must be pressed.



#### Note on switching hysteresis:

With a low hysteresis and short switching cycles, there is a risk that cooling may not be adequate or that only partial sections of the enclosure are cooled. If the cooling unit is oversized and compressor run times are too long < 1 minute, the switching hysteresis to protect the cooling unit is automatically increased.

#### Note on temperature settings:

With the e-Comfort controller, the temperature is preset at the factory to +35°C. In order to save energy, and due to the risk of increased condensation, do not set the temperature lower than that actually necessary.

#### Note on useful cooling power:

Interactive performance diagrams for calculating the useful cooling power may be found at [www.rittal.com](http://www.rittal.com).

In principle, the programming is identical for all editable parameters.

To enter programming mode:

- Press button 2 (“Set”) for approx. 5 seconds.

The controller is now in programming mode. While in programming mode, if you do not press any buttons for approx. 30 seconds, the display will first flash, then the controller will switch back to normal display mode. “Esc” in the display indicates that any changes made have not been saved.

- Press the programming buttons ▲ (°C) or ▼ (°F) to switch between the editable parameters (see tables 3 and 4).

- Press button 2 (“Set”) to select the displayed parameter for editing.

The current value of this parameter is displayed.

- Press one of the programming buttons ▲ (°C) or ▼ (°F).

“Cod” will appear in the display. In order to be able to change a value, you must enter the authorisation code “22”.

- Keep the ▲ programming button (°C) held down until “22” appears.

- Press button 2 (“Set”) to confirm the code.

You can now alter the parameter within the preset limits.

- Press one of the programming buttons ▲ (°C) or ▼ (°F) until the required value appears.

- Press button 2 (“Set”) to confirm the change.

You can now alter other parameters in the same way. There is no need to re-enter the authorisation code “22”.

- To exit programming mode, press button 2 (“Set”) again for approximately five seconds.

“Acc” will appear in the display to indicate that the changes have been saved. The display then switches back to regular operation (internal enclosure temperature).

You can also program the e-Comfort controller using a diagnosis software package (Model No. 3159.100), which is supplied with a connection cable to the PC. The cable connector on the rear of the e-Comfort controller display serves as an interface.

# 6 Operation

## 6.1.5 Editable parameters

See also fig. 20 on page 19.

Progr. level	Display screen	Parameter	Min. value	Max. value	Factory setting	Description
1	St	Internal enclosure temperature set-point $T_i$	20	55	35	The internal enclosure temperature setting is preset at the factory to 35°C and may be altered within a range of 20 – 55°C.
2	Fi	Filter mat monitoring	10	60	99 (= off)	To enable filter mat monitoring, the display should be set to a minimum of 10 K above the temperature difference shown in programming mode “Fi”; filter mat monitoring is disabled at the factory (99 = off).
3	Ad	Master-slave identifier	0	19	0	See “6.1.8 Setting the master/slave identifier”, page 21.
4	CF	Switch between °C/°F	0	1	0	The temperature display can be switched between °C (0) and °F (1). The LED displays the current unit of temperature.
5	H1	Setting for switching difference (hysteresis)	2	10	5	The cooling unit is preset in the factory to a switching hysteresis of 5 K. This parameter should only be changed in consultation with us. Please contact us for advice.
6	H2	Differential for error message A2	3	15	5	If the internal enclosure temperature exceeds the set value by more than 5 K, then error message A2 (internal enclosure temperature too high) appears on the display terminal. If necessary, the differential may be altered here within the range of 3 – 15 K.
26	ECO	Eco-mode operation	0	1	1	Eco mode OFF: 0 / Eco mode ON: 1
27	PSO	Changing the authorisation code	0	15	0	This parameter allows you to change the “22” authorisation code (factory setting). The new code results from the sum of 22 + PSO.

Tab. 3: Editable parameters

## 6.1.6 Programming overview

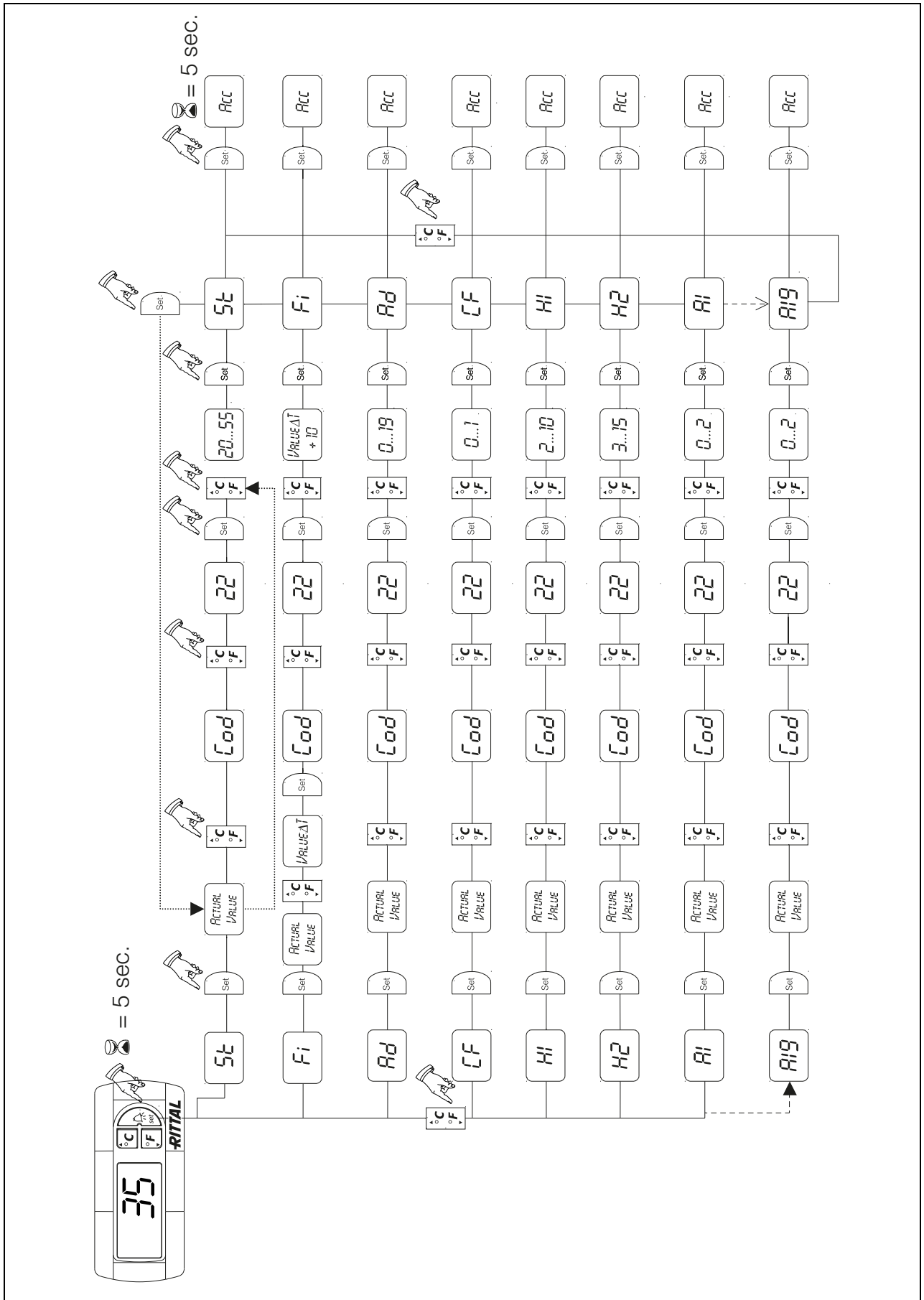

Fig. 19: Programming overview

# 6 Operation

## 6.1.7 Defining system messages for evaluation

System messages are shown on the display screen of the e-Comfort controller via the displays A1 to A20 and E0.

A more detailed explanation of the system messages may be found in section "6.1.9 Evaluating system messages", page 21.  
See also fig. 19 on page 19.

Progr. level	Display screen	Min. value	Max. value	Factory setting	Type or location of fault
7	A1	0	2	0	Enclosure door open
8	A2	0	2	0	Internal temperature of enclosure too high
9	A3	0	2	0	Filter monitoring
10	A4	0	2	0	Ambient temperature too high/low
11	A5	0	2	0	Icing hazard
12	A6	0	2	1	PSA <sup>H</sup> pressure switch
13	A7	0	2	2	Evaporator coil
14	A8	0	2	1	Condensate warning
15	A9	0	2	1	Condenser fan blocked or defective
16	A10	0	2	1	Evaporator fan blocked or defective
17	A11	0	2	2	Compressor
18	A12	0	2	1	Condenser
19	A13	0	2	1	Ambient temperature sensor
20	A14	0	2	1	Icing temperature sensor
21	A15	0	2	1	Condensate warning temperature sensor
22	A16	0	2	1	Internal temperature sensor
23	A17	0	2	1	Phase monitoring
24	A18	0	2	0	EPROM
25	A19	0	2	0	LAN/Master-Slave

Tab. 4: System messages that can be evaluated via relays

The system messages A1 – A19 may also be evaluated via two floating system message relays. In this way, one of the two system message relays may be allocated to each system message.

System message relays with normally open contact, see wiring diagrams at section "4.6.3 Installing the power supply", page 13:

- Terminal 3: NO (normally open, relay 2)
- Terminal 4: C (connection of the supply voltage to the system message relay)
- Terminal 5: NO (normally open, relay 1)

The definition NO refers to the de-energised state. As soon as power is applied to the cooling unit, both system message relays (relay 1 and 2) energise. This is the normal operating state of the cooling unit. As soon as a system message occurs or the power supply is interrupted, the corresponding relay will drop out and open the contact.

The RiDiag II software (available as an accessory, Model No. 3159.100) allows you to invert the system message relay circuit.

In the normal operating state the two relays will then drop out. If a system message occurs, the relevant relay will energise and the contact will close.



**Note:**

This setting can only be made using the RiDiag II software.

- Program system messages with the value
- 0: System message is not sent to the system message relay, but merely appears in the display
  - 1: System message is evaluated by relay 1
  - 2: System message is evaluated by relay 2

### 6.1.8 Setting the master/slave identifier

When several cooling units are connected together (maximum ten), one of the cooling units must be defined as the “master” and the others as “slaves”. For this purpose, assign a corresponding identifier (address) to each cooling unit which will enable the cooling unit to be identified in the network.

If one of the slave units reaches the set temperature or if the door limit switch function is activated, the affected slave unit will report to the master unit, which then deactivates all the other cooling units.



#### Notes:

- Only one unit may be configured as master, and its identifier must match the number of connected slave units.
- The slave units must have different identifiers.
- The identifiers must be numbered in ascending order without any gaps.

On the **master cooling unit** (00 = factory setting), set the number of slave units present in the network:

- 01: Master with 1 slave cooling unit
- 02: Master with 2 slave cooling units
- 03: Master with 3 slave cooling units
- 04: Master with 4 slave cooling units
- 05: Master with 5 slave cooling units
- 06: Master with 6 slave cooling units
- 07: Master with 7 slave cooling units
- 08: Master with 8 slave cooling units
- 09: Master with 9 slave cooling units

On the **slave cooling unit** (00 = factory setting), set its own address:

- 11: Slave cooling unit no. 1
- 12: Slave cooling unit no. 2
- 13: Slave cooling unit no. 3
- 14: Slave cooling unit no. 4
- 15: Slave cooling unit no. 5
- 16: Slave cooling unit no. 6
- 17: Slave cooling unit no. 7
- 18: Slave cooling unit no. 8
- 19: Slave cooling unit no. 9

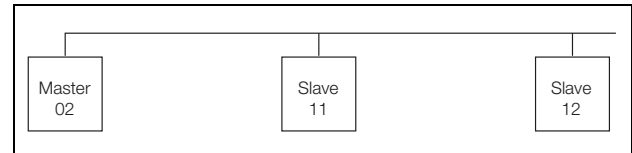

Fig. 20: Master/slave connection (example)

For further connection examples, see “4.6.1 Bus connection (only when interconnecting several units with a Comfort controller)”, page 11.

For details of how to set the identifier, see “6.1.5 Editable parameters”, page 18 or “6.1.6 Programming overview”, page 19, parameter “Ad”.

### 6.1.9 Evaluating system messages

In the e-Comfort controller, system messages are indicated by a number in the display.

Following the appearance of messages A03, A06 and A07 and after rectifying their cause, you will need to reset the e-Comfort controller (see “6.1.10 Resetting the e-Comfort controller”, page 23).

# 6 Operation

EN

Display screen	System message	Possible cause	Measures to rectify the fault
A01	Enclosure door open	Door open or door limit switch incorrectly positioned	Close door, position door limit switch correctly, check connection if necessary
A02	Internal temperature of enclosure too high	Cooling capacity inadequate/unit undersized. Error as a consequence of messages A03 to A17.	Check cooling capacity
A03	Filter monitoring	Filter mat soiled	Clean or replace; reset the e-Comfort controller
A04	Ambient temperature too high/low	Ambient temperature outside permissible operating range (+10°C to +60°C)	Raise or lower the ambient temperature (e.g. heat or ventilate the room)
A05	Icing hazard	Operational display in case of icing hazard. Evaporator coil fan may be mechanically blocked, defective, or cold air outlet obstructed.	Set the enclosure interior temperature to a higher value. Check the evaporator fan; release or exchange if necessary.
A06	PSA <sup>H</sup> pressure switch	Ambient temperature too high	Lower the ambient temperature; reset the e-Comfort controller
		Condenser soiled	Clean the condenser; reset the e-Comfort controller
		Filter mat soiled	Clean or replace; reset the e-Comfort controller
		Condenser fan defective	Replace; reset the e-Comfort controller
		E-valve defective	Repair by refrigeration engineer; reset the e-Comfort controller
		PSA <sup>H</sup> pressure switch defective	Refrigeration engineer to exchange reset the e-Comfort controller
A07	Evaporator coil	Lack of refrigerant; Sensor in front of or behind condenser defective	Repair by refrigeration engineer; reset the e-Comfort controller
A08	Condensate warning	Condensate discharge kinked or blocked	Check condensate drainage; correct any kinks or blockages in the hose
		Only for units with optional condensate evaporation	Check the evaporation unit, replace if necessary
A09	Condenser fan	Blocked or defective	Clear the blockage; replace if necessary
A10	Evaporator fan	Blocked or defective	Clear the blockage; replace if necessary
A11	Compressor	Compressor overloaded (internal winding protection)	No action required; Unit switches on again independently
		Defective (check by measuring the winding resistance)	Replace by a refrigeration engineer
A12	Condenser temperature sensor	Open or short-circuit	Replace
A13	Ambient temperature sensor	Open or short-circuit	Replace
A14	Icing temperature sensor	Open or short-circuit	Replace
A15	Condensate warning temperature sensor	Open or short-circuit	Replace
A16	Internal temperature sensor	Open or short-circuit	Replace
A17	Phase monitoring	For three-phase devices only: Incorrect rotary field/phase absent	Swap two phases
A18	EPROM error	New board installed incorrectly	Software update needed (only following board installation with more recent software): Enter the programming level with Code 22; press button 1 and confirm with "Set" until "Acc" appears. Next, disconnect the unit from the mains and reconnect.
A19	LAN/Master-Slave	Master and slave not connected	Check setting and/or cable
A20	Voltage drop	Error display not shown	Event is stored in the log file
E0	Display message	Connection problem between the display and the controller board	Reset: Switch power supply off, then switch on again after approx. 2 sec.
		Cable defective; connection loose	Replace the boards
OL	Overload	Ambient parameters or heat loss outside the applicable limits	
b07	Leak in the cooling circuit	Sensor B3 and B4 swapped over	Swap the sensors
rSt	Reset	Manual device reset required, see "6.1.10 Resetting the e-Comfort controller", page 23.	

Tab. 5: Troubleshooting with the e-Comfort controller

## 6.1.10 Resetting the e-Comfort controller

After the occurrence of faults A03, A06 and A07, you will need to reset the e-Comfort controller.

- Press buttons 1 (▲) and 3 (▼) (fig. 17) simultaneously for 5 seconds.

The system messages disappear and the temperature display is shown.

## 7 Inspection and maintenance



**Risk of electric shock!**  
**The unit is live.**  
**Switch off the power supply before opening, and take suitable precautions against it being accidentally switched back on.**

The cooling circuit is designed in the form of a maintenance-free, hermetically sealed system. The cooling unit is filled with the required quantity of refrigerant at the factory, checked for leaks, and subjected to a functional test run.

The installed maintenance-free fans are mounted on ball bearings, protected against moisture and dust, and fitted with a temperature monitor. The life expectancy is at least 30,000 operating hours. The cooling unit is thus largely maintenance-free. All that may be required from time to time is to clean the components of the external air circuit using a vacuum cleaner or compressed air if they become visibly dirty. Any stubborn, oily stains may be removed using a non-flammable detergent, such as degreaser. Maintenance interval: 2,000 operating hours. Depending on the level of contamination in the ambient air, the maintenance interval may be reduced to suit the air pollution intensity.



**Caution!**  
**Risk of fire!**  
**Never use flammable liquids for cleaning.**

Sequence of maintenance measures:

- Check the level of dirt.
- Filter soiling? Replace the filter if necessary.
- Cooling membranes soiled? Clean if necessary.
- Activate test mode; cooling function OK?
- Check noise generation of compressor and fans.

## 7.1 Compressed air cleaning

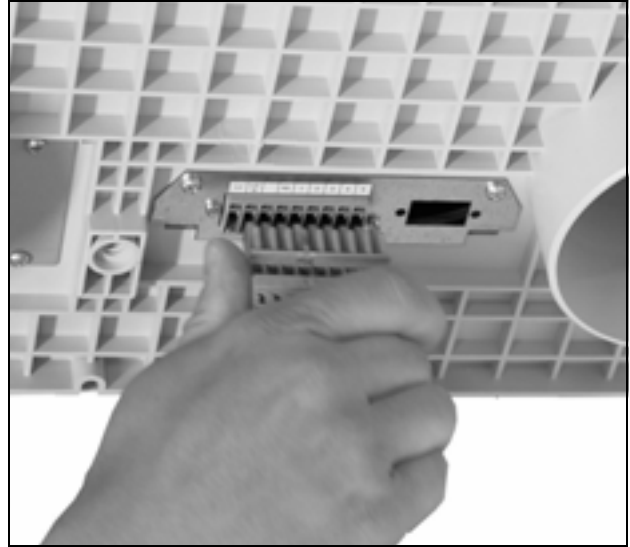

Fig. 21: Disconnect the mains plug



Fig. 22: Release the louvered grille



Fig. 23: Remove the louvered grille

## 7 Inspection and maintenance

EN



Fig. 24: Disconnect the connector from the display



Fig. 27: Remove the cover



Fig. 25: Disconnect the earthing cable

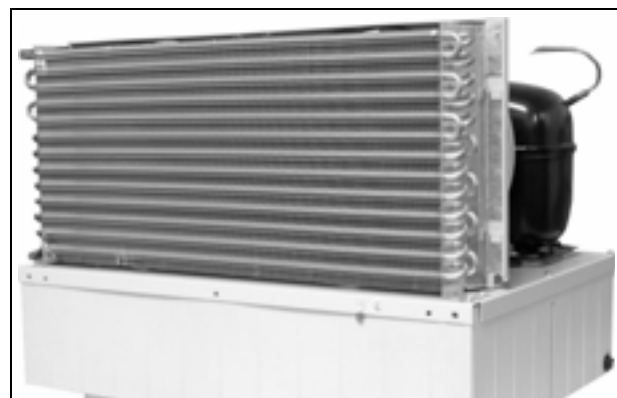

Fig. 28: Cooling unit without cover (front view)



Fig. 26: Remove the assembly screws from the cover (loosen four screws)



Fig. 29: Cooling unit without cover (rear view)



## 8 Storage and disposal

EN

### 8 Storage and disposal



**Caution! Risk of damage!**  
**The cooling unit must not be subjected to temperatures above +70°C during storage.**

During storage, the cooling unit must stand upright. The closed cooling cycle contains refrigerant and oil, which must be properly disposed of for the protection of the environment. Facilities for disposal are available at the Rittal plant. Please contact us for advice.

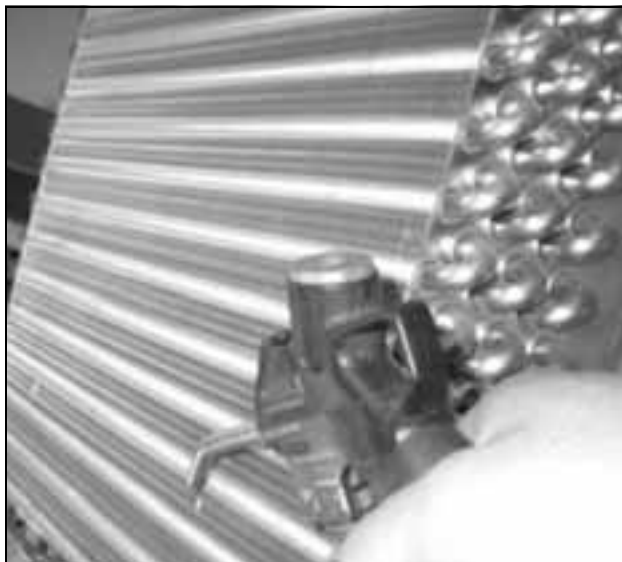

*Fig. 30: Clean the heat exchanger coil and compressor chamber using compressed air*

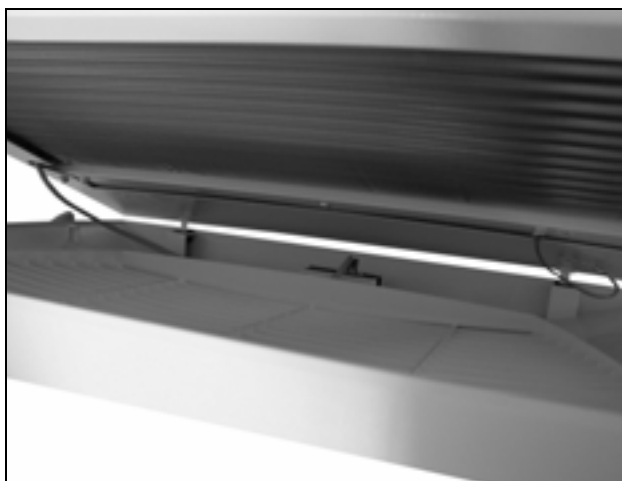

*Fig. 31: Fit the louvred grille*

# 9 Technical details

## 9 Technical details

### 9.1 Technical specifications

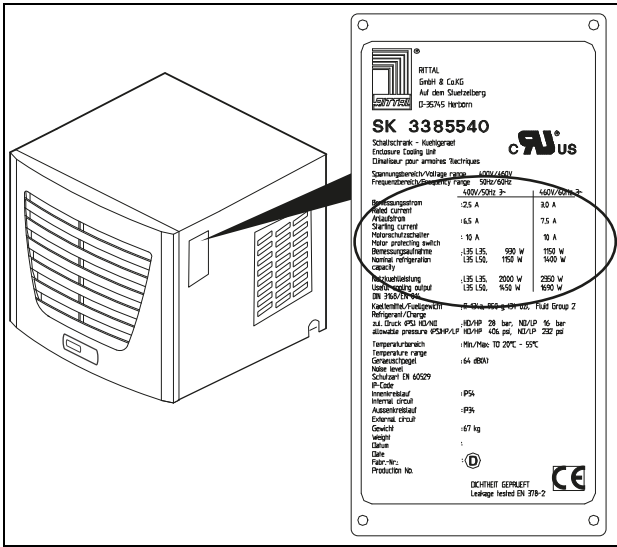

Fig. 32: Rating plate (technical data)

- Observe the mains connection data (voltage and frequency) as per the rating plate.
- Observe the pre-fuse as per the specifications on the rating plate.

	Unit	Model No.								
<b>e-Comfort controller, RAL 7035</b>	–	<b>3382.500</b>	<b>3382.510</b>	<b>3359.500</b>	<b>3359.510</b>	<b>3359.540</b>	<b>3383.500</b>	<b>3383.510</b>	<b>3383.540</b>	
<b>e-Comfort controller, Stainless steel cover</b>	–	<b>3382.600</b>	<b>3382.610</b>	<b>3359.600</b>	<b>3359.610</b>	<b>3359.640</b>	<b>3383.600</b>	<b>3383.610</b>	<b>3383.640</b>	
Rated voltage	V Hz	230, 1~, 50/60	115, 1~, 50/60	230, 1~, 50/60	115, 1~, 50/60	400, 2~, 50/60	230, 1~, 50/60	115, 1~, 50/60	400, 2~, 50/60	
Rated current	A	2.3/2.6	4.1/5.4	2.8/3.7	5.6/7.4	1.6/2.1	2.9/3.9	6.2/8.4	1.7/2.2	
Start-up current	A	9.1/18.8	18.2/15.9	9.2/9.0	18.4/18.0	5.4/5.2	8.8/10.1	14.4/15.8	4.6/5.7	
Pre-fuse T	A	10.0	–	10.0	–	–	10.0	–	–	
Motor circuit-breaker	–	–	–	–	–	–	–	–	–	
Transformer circuit-breaker	–	–	6.3 to 1.0	–	11 to 16	6.3 to 1.0	–	11 to 16	6.3 to 10	
Miniature circuit-breaker or gG slow fuse (T)	–	■	–	■	–	–	■	–	–	
Total cooling output P <sub>c</sub> L 35 L 35 to DIN EN 14511 L 35 L 50	kW kW	0.55/0.62 0.42/0.48	0.55/0.62 0.42/0.58	0.77/0.79 0.52/0.47	0.77/0.79 0.52/0.47	0.77/0.79 0.52/0.47	1.00/1.09 0.71/0.81	1.00/1.09 0.71/0.81	1.00/1.09 0.71/0.81	
Sensible cooling output P <sub>s</sub> to DIN EN 14511 L 35 L 35	kW	0.37/0.42	0.37/0.42	0.76/0.78	0.76/0.78	0.76/0.78	1.00/1.09	1.00/1.09	1.00/1.09	
Power consumption P <sub>el</sub> L 35 L 35 to DIN EN 14511 L 35 L 50	kW kW	0.27/0.31 0.31/0.37	0.27/0.31 0.31/0.37	0.33/0.42 0.49/0.42	0.33/0.43 0.49/0.42	0.33/0.43 0.49/0.42	0.38/0.47 0.45/0.57	0.38/0.45 0.43/0.54	0.38/0.45 0.42/0.54	
Energy efficiency ratio (EER) 50 Hz L 35 L 35		2.04		2.28			2.58	2.58		
Refrigerant – Type – Filling	– g	R134a 300		R134a 400			R134a 650			
Permissible pressure	bar	28								
Operating temperature range	°C	+10 to +55								
Setting range	°C	+20 to +55								
Noise level	dB (A)	59		60			62			
Protection category to IEC 60 529 – Internal circuit – External circuit	– –	IP 54 IP 34								
Dimensions (W x H x D)	mm	597 x 417 x 380					597 x 417 x 475			
Weight	kg	30	35	32	37		40	46		

## 9 Technical details

EN

	Unit	Model No.							
<b>e-Comfort controller, RAL 7035</b>	–	<b>3273.500</b>	<b>3273.515</b>	<b>3384.500</b>	<b>3384.510</b>	<b>3384.540</b>	<b>3385.500</b>	<b>3385.510</b>	<b>3385.540</b>
<b>e-Comfort controller, Stainless steel cover</b>	–	–	–	<b>3384.600</b>	<b>3384.610</b>	<b>3384.640</b>	<b>3385.600</b>	<b>3385.610</b>	<b>3385.640</b>
Rated voltage	V Hz	230, 1~, 50/60	115, 1~, 50/60	230, 1~, 50/60	115, 1~, 50/60	400, 2~, 50/60	230, 1~, 50/60	115, 1~, 50/60	400, 2~, 50/60
Rated current	A	5.2/5.4	11.0/11.5	3.9/4.8	8.5/15.3	2.4/2.8	5.9/6.3	13.5/14.2	3.7/4.2
Start-up current	A	15.5/16.5	32.0/35.0	14.8/16.0	27.2/27.2	8.7/9.0	19.7/17.9	36.0/32.0	36.0/32.0
Pre-fuse T	A	10.0	–	10.0	–	–	10.0	–	–
Motor circuit-breaker	–	–	–	–	–	–	–	–	–
Transformer circuit-breaker	–	–	11 to 16	–	14 to 20	6.3 to 10	–	14 to 20	6.3 to 10
Miniature circuit-breaker or gG slow fuse (T)	–	■	–	■	–	–	■	–	–
Total cooling output P <sub>c</sub> to DIN EN 14511	L 35 L 35 L 35 L 50 kW kW	1.10/1.20 0.85/0.87	1.10/1.20 0.85/0.87	1.50/1.65 1.15/1.30	1.50/1.65 1.15/1.30	1.50/1.65 1.15/1.30	2.00/2.14 1.41/1.51	2.00/2.14 1.41/1.51	2.00/2.14 1.41/1.51
Sensible cooling output P <sub>s</sub> to DIN EN 14511	L 35 L 35 kW	1.10/1.20	1.10/1.20	1.32/1.45	1.32/1.45	1.32/1.45	1.79/1.92	1.79/1.92	1.79/1.92
Power consumption P <sub>el</sub> to DIN EN 14511	L 35 L 35 L 35 L 50 kW kW	0.51/0.53 0.59/0.73	0.51/0.53 0.59/0.74	0.67/0.77 0.79/0.91	0.67/0.76 0.79/0.93	0.67/0.76 0.79/0.93	0.95/1.14 1.07/1.23	0.95/1.17 1.07/1.24	0.95/1.17 1.07/1.24
Energy efficiency ratio (EER) 50 Hz	L 35 L 35	2.12		2.24	2.24		2.09	2.09	
Refrigerant – Type – Filling	– g	R134a 700		R134a 500			R134a 900		
Permissible pressure	bar	28							
Operating temperature range	°C	+10 to +55							
Setting range	°C	+20 to +55							
Noise level	dB (A)	51			61		70		
Protection category to IEC 60 529 – Internal circuit – External circuit	– –	IP 54 IP 34							
Dimensions (W x H x D)	mm	597 x 417 x 475							
Weight	kg	42	47	41	47	42	48		

## 9 Technical details

EN

	Unit	Model No.	
<b>e-Comfort controller, RAL 7035</b>	–	<b>3386.540</b>	<b>3387.540</b>
<b>e-Comfort controller, Stainless steel cover</b>	–	<b>3386.640</b>	<b>3387.640</b>
Rated voltage	V, Hz	400, 3–, 50/ 460, 3–, 60	
Rated current	A	3.4/3.4	3.9/3.9
Start-up current	A	8.0/9.0	17.0/19.0
Pre-fuse T	A	–	
Motor circuit-breaker	–	6.3 to 10	
Transformer circuit-breaker	–	–	
Miniature circuit-breaker or gG slow fuse (T)	–	–	
Total cooling output P <sub>c</sub> to DIN EN 14511	L 35 L 35 L 35 L 50	kW kW	3.00/3.30 2.20/2.50
Sensible cooling output P <sub>s</sub> to DIN EN 14511	L 35 L 35 L 35 L 50	kW kW	2.70/3.18 3.47/3.70
Power consumption P <sub>el</sub> to DIN EN 14511	L 35 L 35 L 35 L 50	kw kw	1.17/1.48 1.42/1.76
Energy efficiency ratio (EER) 50 Hz	L 35 L 35		2.56 2.38
Refrigerant – Type – Filling	– g	R134a 1600	R134a 1800
Permissible pressure	bar	28	
Operating temperature range	°C	+10 to +55	
Setting range	°C	+20 to +55	
Noise level	dB (A)	64	70
Protection category to IEC 60 529 – Internal circuit – External circuit	– –	IP 54 IP 34	
Dimensions (W x H x D)	mm	796 x 470 x 580	
Weight	kg	70	77

## 9.2 Performance diagrams

### 9.2.1 Single-phase by output category

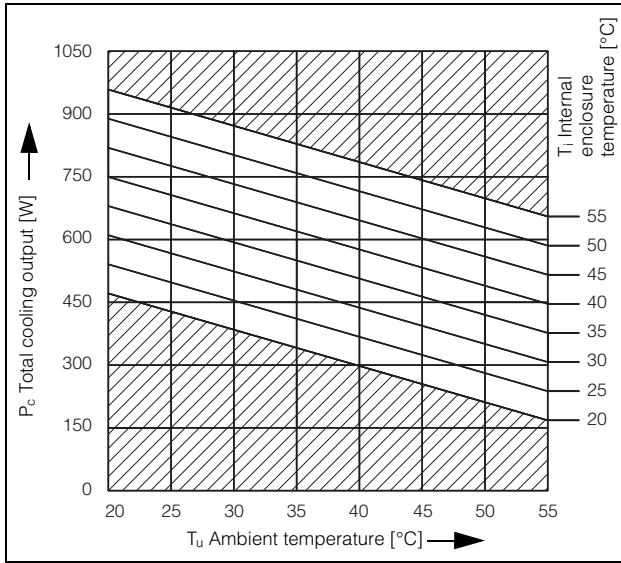

Fig. 33: 3382.xxx, 500 W, 50 Hz

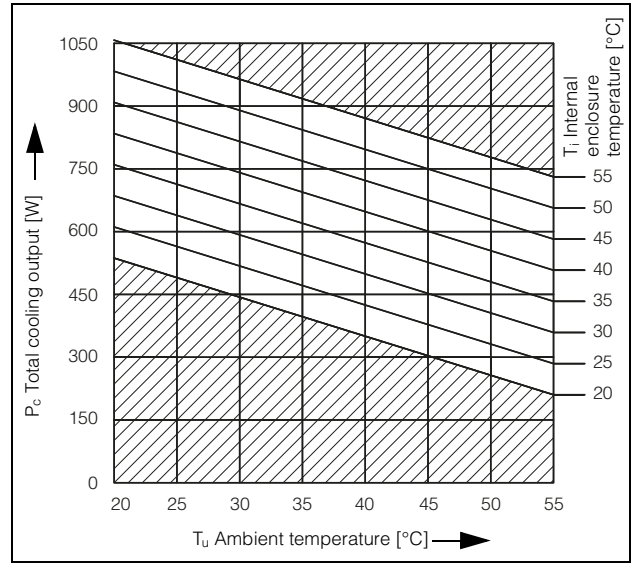

Fig. 34: 3382xxx, 500 W, 60 Hz

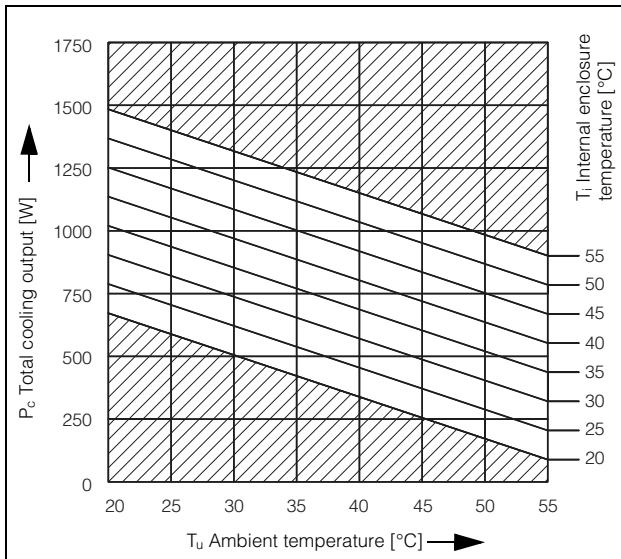

Fig. 35: 3359.xxx, 750 W, 50 Hz

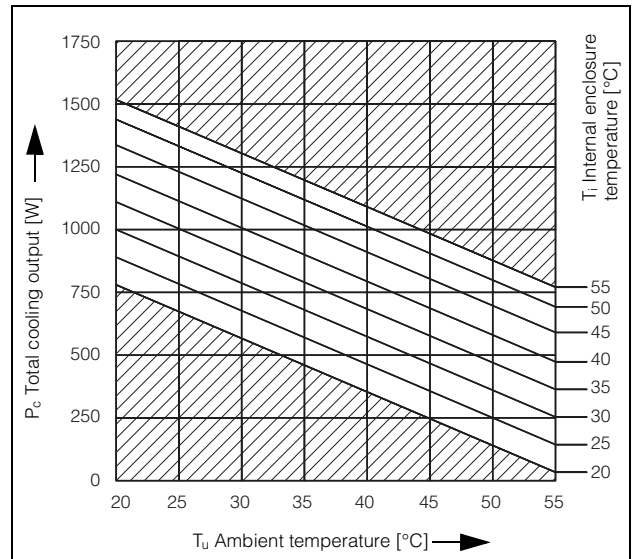

Fig. 36: 3359.xxx, 750 W, 60 Hz

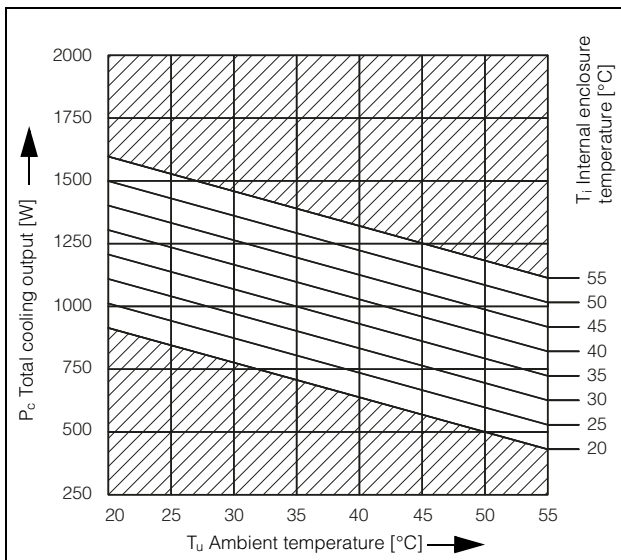

Fig. 37: 3383.xxx, 1000 W, 50 Hz

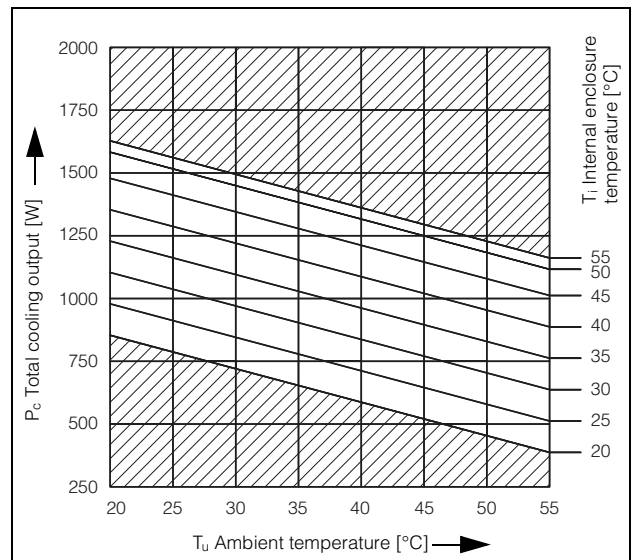

Fig. 38: 3383.xxx, 1000 W, 60 Hz

# 9 Technical details

EN

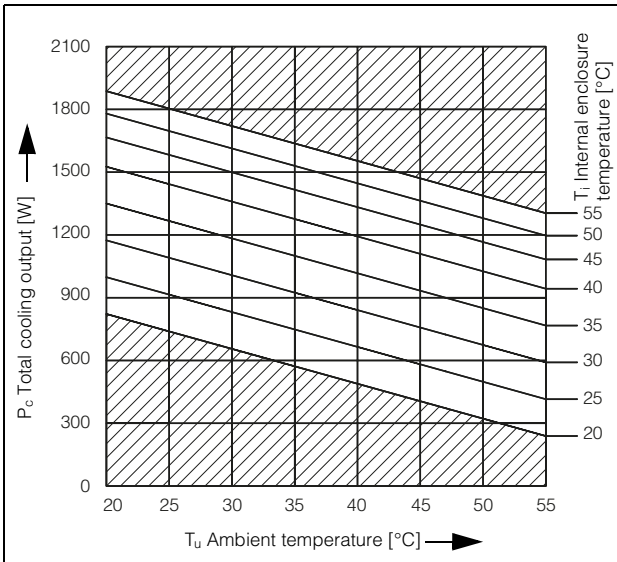

Fig. 39: 3273.xxx, 1100 W, 50 Hz

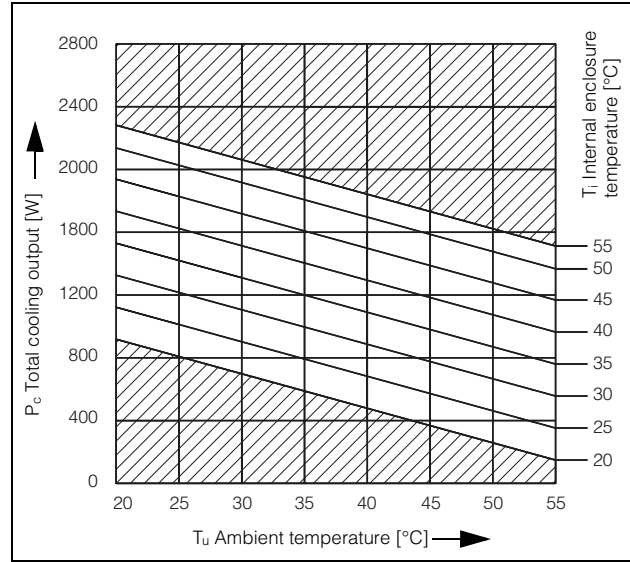

Fig. 40: 3273.xxx, 1100 W, 60 Hz

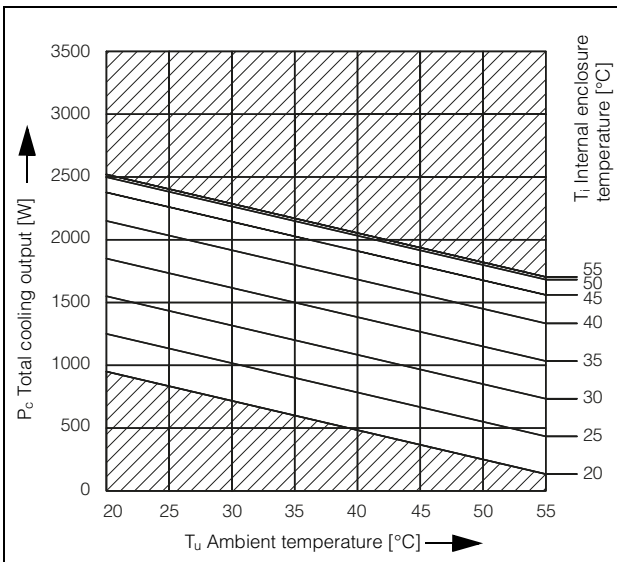

Fig. 41: 3384.xxx, 1500 W, 50 Hz

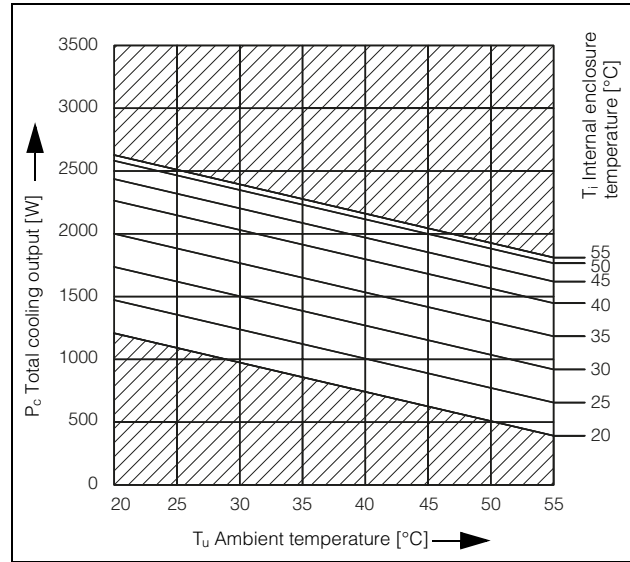

Fig. 42: 3384.xxx, 1500 W, 60 Hz

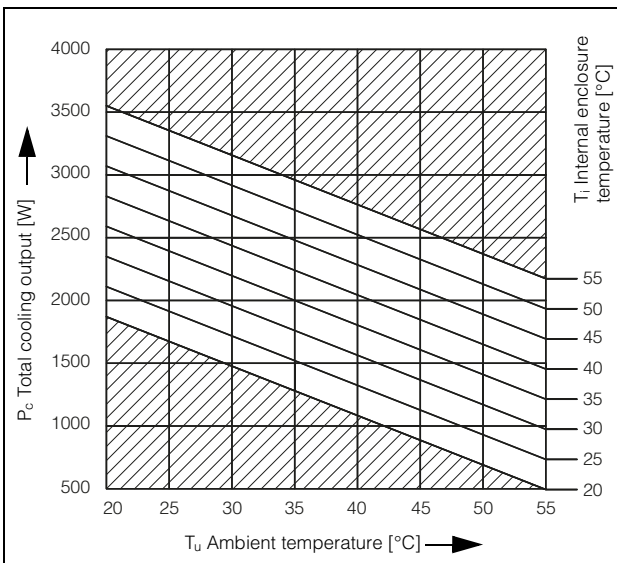

Fig. 43: 3385.xxx, 2000 W, 50 Hz

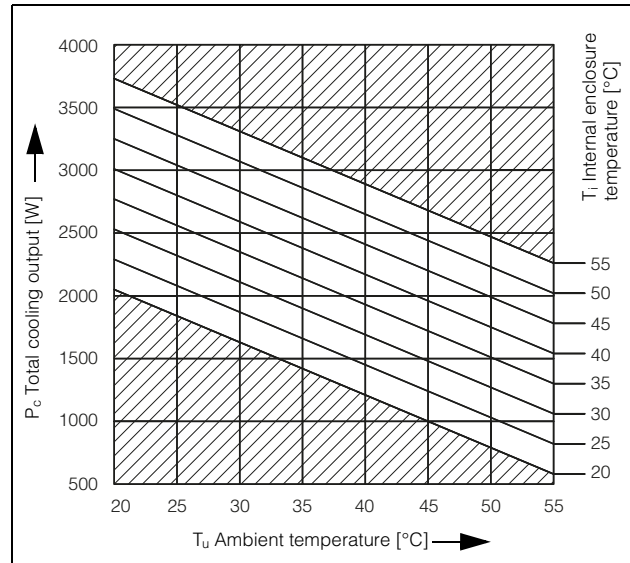

Fig. 44: 3385.xxx, 2000 W, 60 Hz

## 9.2.2 3-phase by output category

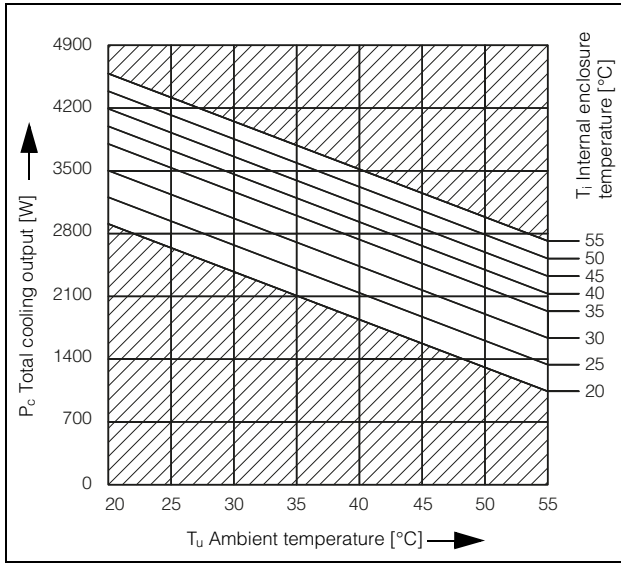

Fig. 45: 3386.xxx, 3000 W, 50 Hz

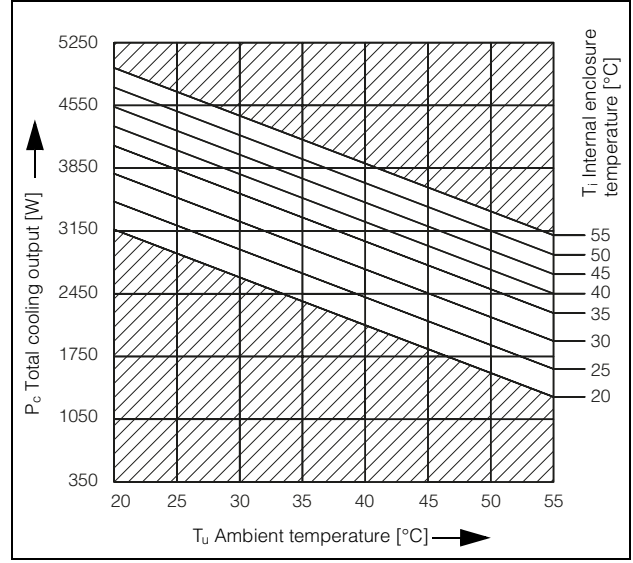

Fig. 46: 3386.xxx, 3000 W, 60 Hz

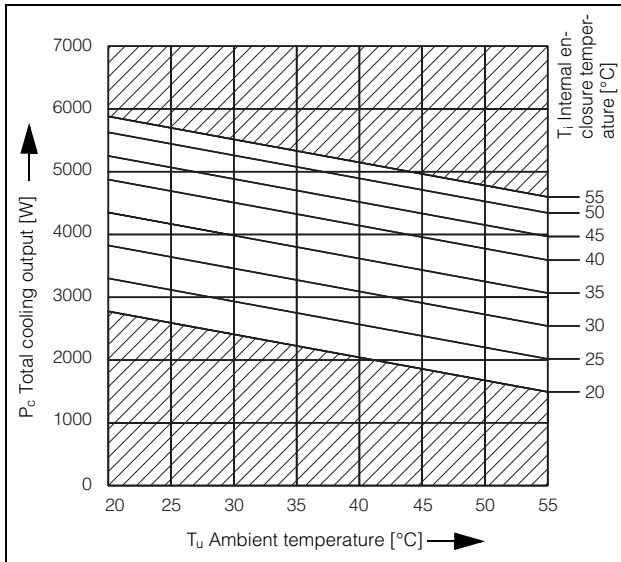

Fig. 47: 3387.xxx, 4000 W, 50 Hz

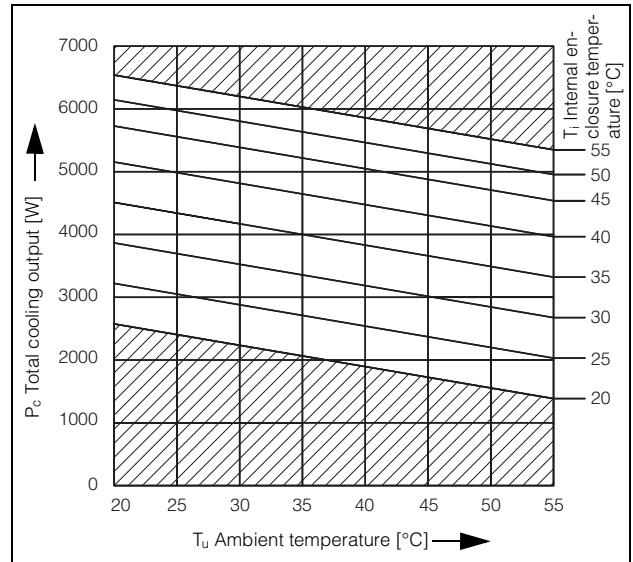

Fig. 48: 3387.xxx, 4000 W, 60 Hz

# 10 List of spare parts

## 10 List of spare parts

EN

3359.xxx, 3382.xxx

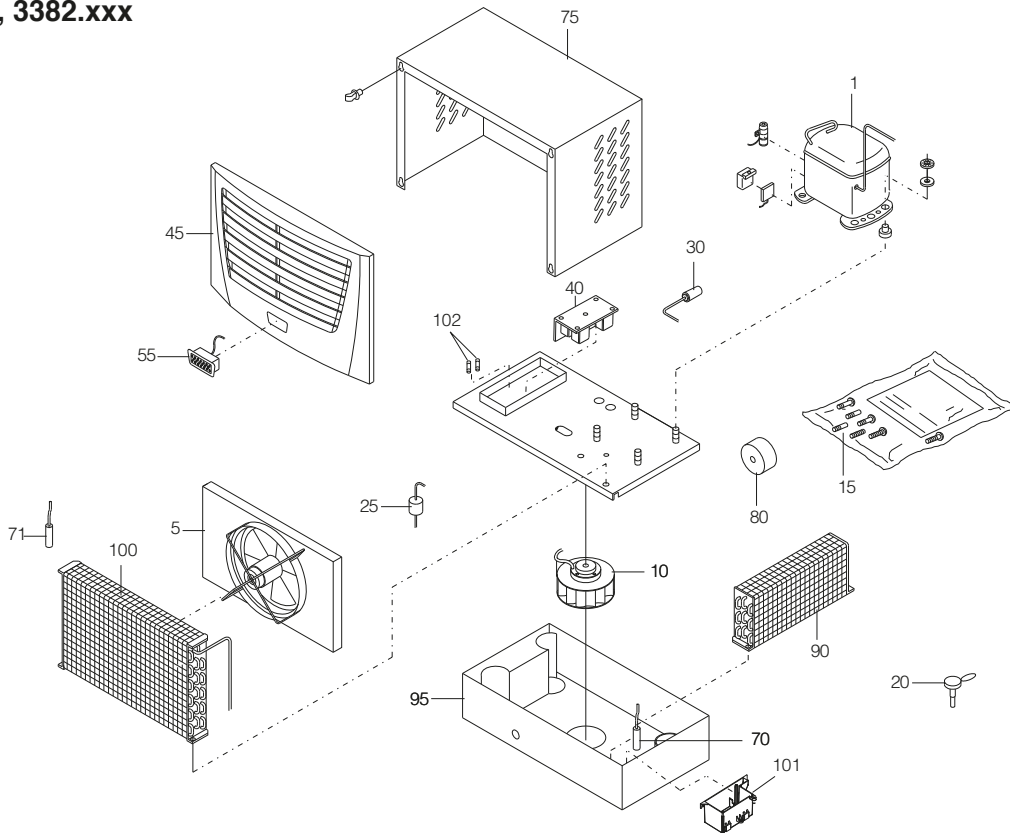

Fig. 49: Spare parts for 3359.xxx, 3382.xxx

3273.xxx, 3383.xxx, 3384.xxx, 3385.xxx

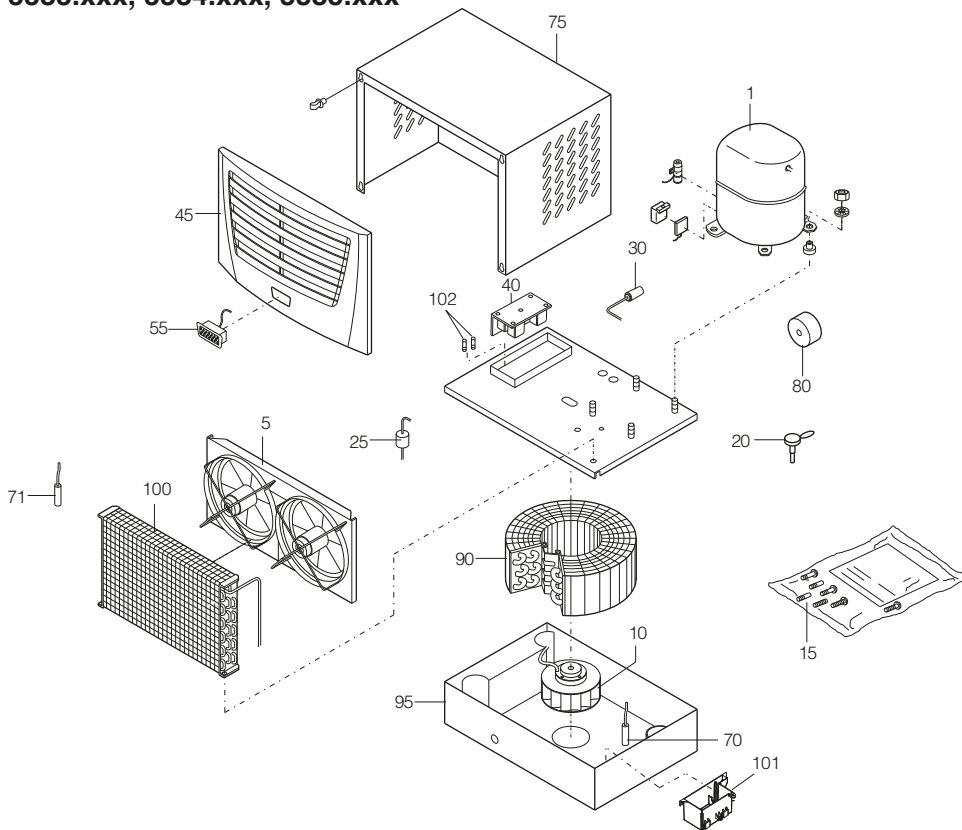

Fig. 50: Spare parts for 3273.xxx, 3383.xxx, 3384.xxx, 3385.xxx



## 3386.xxx, 3387.xxx

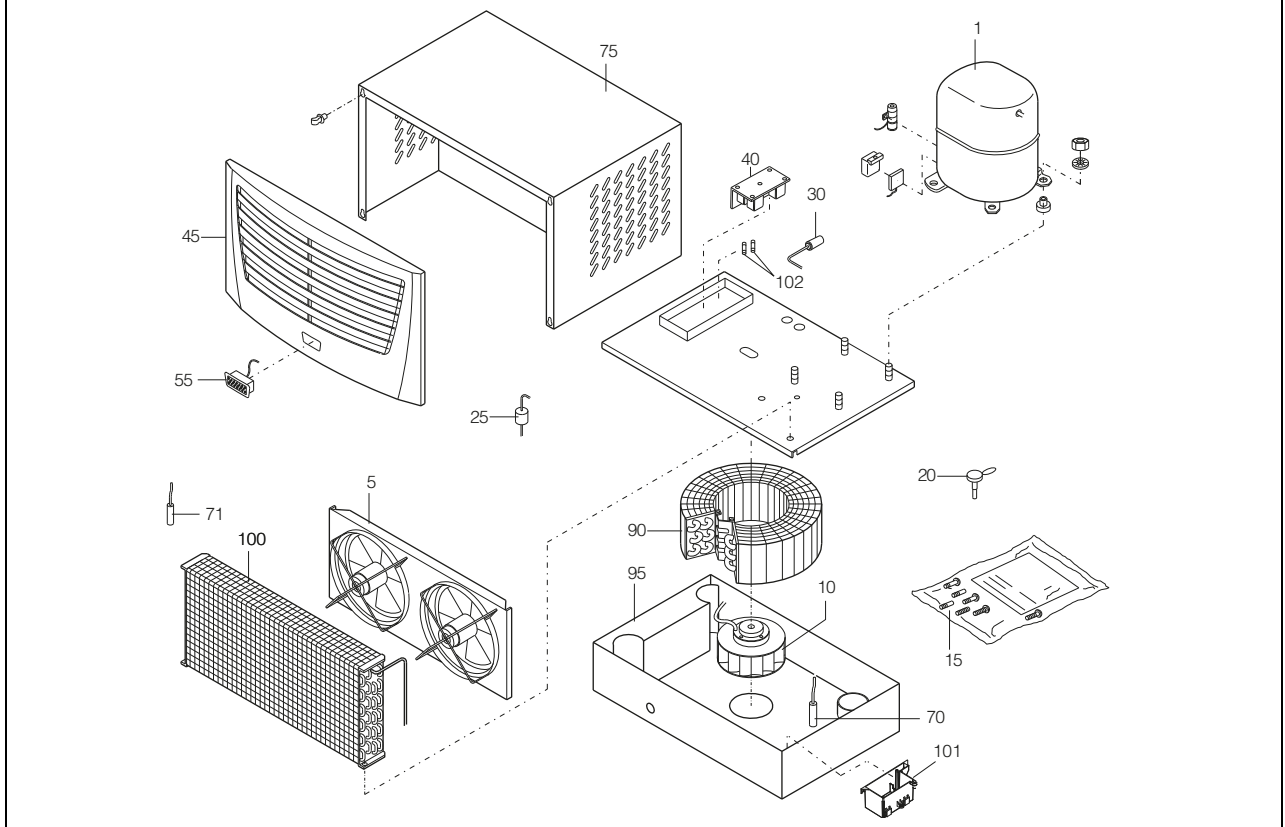

Fig. 51: Spare parts for 3386.xxx, 3387.xxx

### Key

- 1 Compressor
- 5 Condenser fan
- 10 Evaporator fan
- 15 Dispatch bag
- 20 Expansion valve
- 25 Filter dryer
- 30 PSA<sup>H</sup> pressure switch
- 40 Controller board
- 45 Louvred grille
- 55 Display
- 71 Temperature sensor
- 75 Enclosure tray
- 80 Transformer
- 90 Evaporator coil
- 100 Condenser
- 101 Condensate evaporator
- 102 Miniature fuse, condensate evaporator (T4A; 6.3 x 32 mm)



### Note:

As well as the spare part number, when ordering spare parts the following information must be provided:

- Unit model
- Fabrication number
- Date of manufacture

This information may be found on the rating plate.

# 11 Appendix: Cut-out and hole sizes

## 11 Appendix: Cut-out and hole sizes

### 11.1 Dimensions for assembly

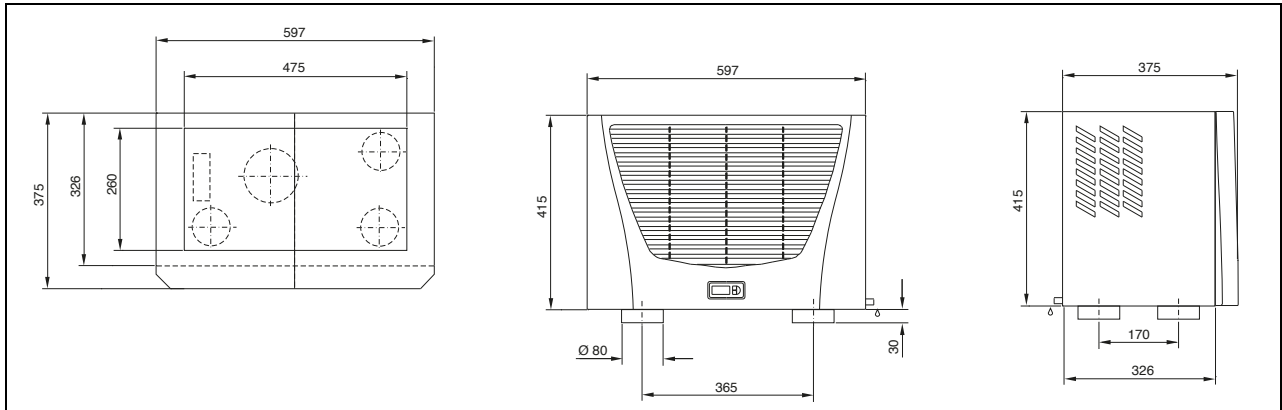

Fig. 52: 3359.xxx, 3382.xxx assembly

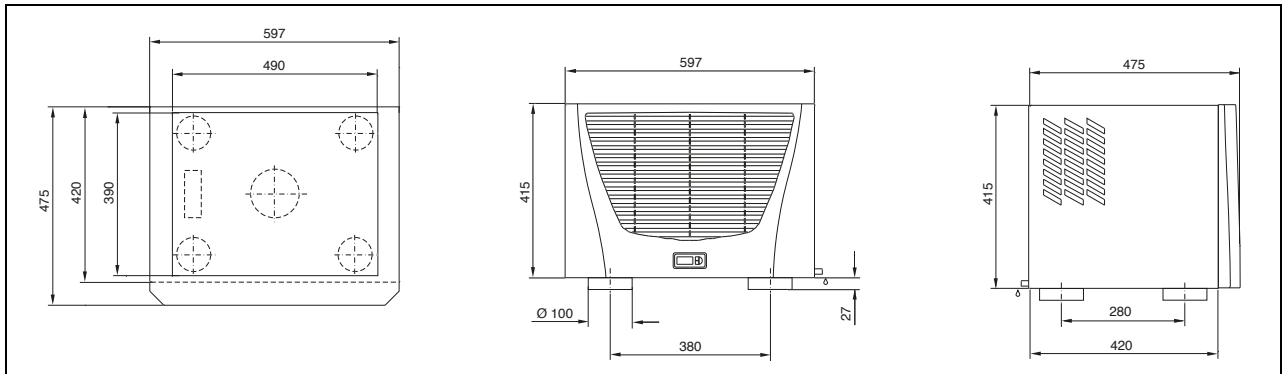

Fig. 53: 3273.xxx, 3383.xxx, 3384.xxx, 3385.xxx assembly

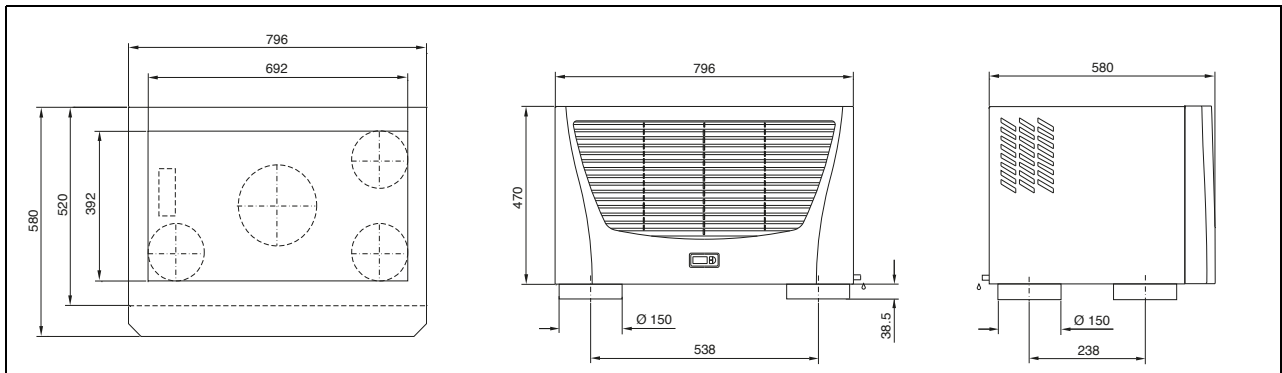

Fig. 54: 3386.xxx, 3387.xxx assembly

# Rittal – The System.

---

**Faster – better – everywhere.**

- Enclosures
- Power Distribution
- Climate Control
- IT Infrastructure
- Software & Services

RITTAL GmbH & Co. KG  
Postfach 1662 · D-35726 Herborn  
Phone +49(0)2772 505-0 · Fax +49(0)2772 505-2319  
E-mail: [info@rittal.de](mailto:info@rittal.de) · [www.rittal.com](http://www.rittal.com)

ENCLOSURES

POWER DISTRIBUTION

CLIMATE CONTROL

IT INFRASTRUCTURE

SOFTWARE & SERVICES



FRIEDHELM LOH GROUP