

FLANGEABLE PILOT ASSISTED OVERCENTRE VALVES SERIES "NA"

AUBSOSE-FC-NA34-1:2.5-35

08.41.65.90.04.35.00.0

DENOMINAZIONE VALVOLA
VALVE DENOMINATION

CODICE D'ORDINAZIONE
ORDERING CODE

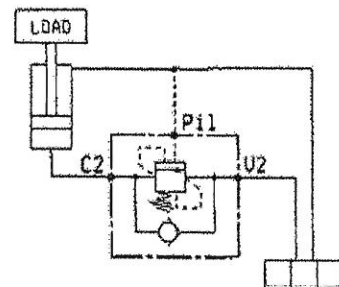
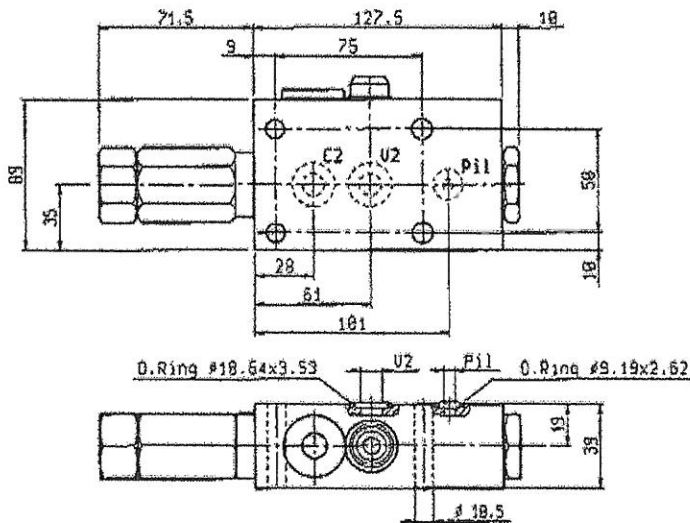

Pressione max 350 bar / Max pressure 350 bar

Taratura della valvola: almeno 1,3 volte superiore alla pressione indotta dal carico

Portata max 200 l/min.

Cappellotto per pinnobatura
Sealing cap

Peso Kg.

Pressure setting: at least 1.3 times the load induced pressure

Flow max 200 l/min.

Codice / Ordering code
N° 83.05.01.001

Weight Kg.

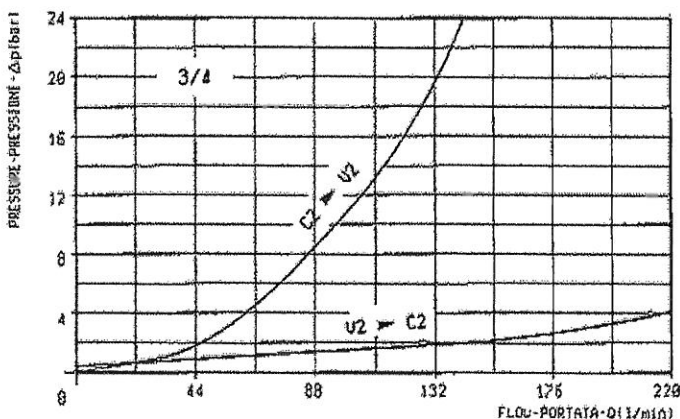

RAPPORTO DI PILOTAGGIO PILOT RATIO	
2.5 : 1	

MOLLE - SPRINGS				
Campo taratura min-max bar Adj. press. range bar	Incremento pressione bar/giro vite Pressure increase bar/turn	Taratura bar(0.5 l/1") Setting bar (made at 5 l/1")	Codice ordinazione Ordering code	Colore Colour
100-350	105	350	03.51.01.142	giallo yellow

ATTACCHI / PORT SIZE	
U2 - C2	P11
Ø 14	Ø 5

011.03

catloghi/na/0841659004-35000