

MASSE GENERALE (MG)

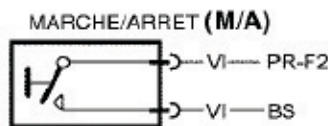

CARTE DE PUISSANCE (CP)

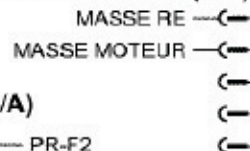
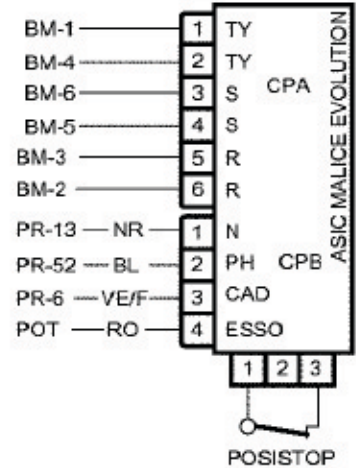

POMPE (PV)

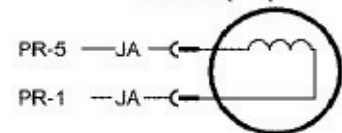

BLOC SECTEUR (BS)

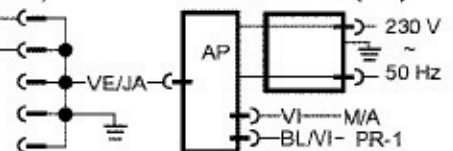

ARRET CUVE PLEINE (ACP)

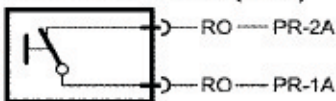

RINCAGE+ (R+)

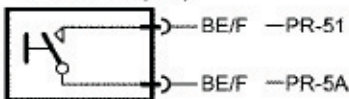

POTENTIOMETRE VITESSE (POT)

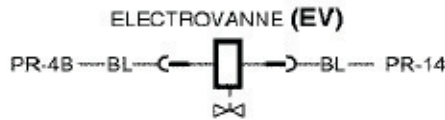
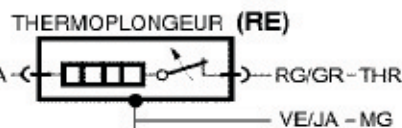
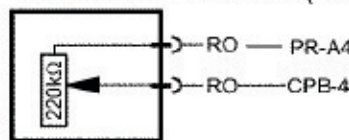

VERROU PORTE (VP)

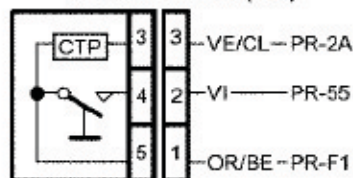

BORNIER MOTEUR (BM)

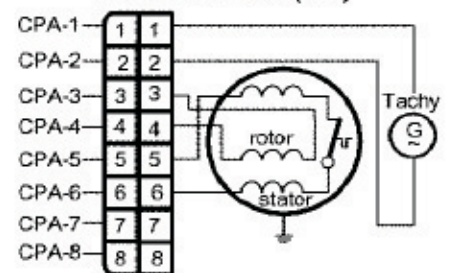

BE	: Bleu	OR	: Orange
BE/CL	: Bleu Clair	RO	: Rose
BE/F	: Bleu Fonce	RG	: Rouge
BL	: Blanc	VE	: Vert
GR	: Gris	VE/CL	: Vert Clair
JA	: Jaune	VE/F	: Vert Fonce
MA	: Marron	VI/JA	: Violet Jaune
NR	: Noir	OR/BE	: Orange Bleu