

ST-S550ES

SERVICE MANUAL

*US Model
Canadian Model
AEP Model
UK Model*



Photo: Except for US model.

SPECIFICATIONS

FM tuner		Selectivity	at 400 kHz
Tuning range	87.5 – 108 MHz		80 dB (WIDE)
Intermediate frequency	10.7 MHz		90 dB (NARROW)
Sensitivity at 46 dB quieting			at 300 kHz
16.8 dBf 1.8 μ V/75 ohms	} (mono)		45 dB (WIDE)
for other countries			70 dB (NARROW)
16.8 dBf 3.6 μ V			40 dB (WIDE)
for US, Canadian model			65 dB (NARROW)
		Output	at 75 kHz deviation (US, Canadian model)
38.5 dBf 23 μ V/75 ohms	} (stereo)		750 mV
for other countries			at 40 kHz deviation
38.5 dBf 46 μ V			400 mV for UK model
			600 mV for AEP, West Germany, Italian Model
Usable sensitivity	10.3 dBf 0.9 μ V/75 ohms		
	for other countries		
	10.3 dBf 1.8 μ V		
	for US, Canadian model	AM tuner	
Signal-to-noise ratio	at 75 kHz deviation (US, Canadian model)	Tuning range	AEP, UK, West Germany model :
	82 dB (mono)		MW: 531 – 1,602 kHz (9 kHz step)
	78 dB (stereo)		LW: 153 – 279 kHz (1 kHz step)
	at 40 kHz deviation		Italian model :
	(Models for other countries)		MW: 522 – 1,611 kHz (9 kHz step)
	76 dB (mono)		LW: 144 – 288 kHz (1 kHz step)
	72 dB (stereo)		US, Canadian model:
Harmonic distortion	WIDE 0.04% (mono)		AM: 530 – 1,710 kHz (10 kHz step)
	0.05% (stereo)		531 – 1,710 kHz (9 kHz step)
	NARROW 0.06% (mono)	Intermediate frequency	
	0.08% (stereo)		450 kHz
Separation at 1 kHz	65 dB		

– Continued on page 2 –

FM STEREO / FM-AM TUNER
SONY®

Usable sensitivity	MW : AM loop antenna 250 μ V/m External antenna 30 μ V/m LW : AM loop antenna 700 μ V/m External antenna 200 μ V/m
Signal-to-noise ratio	50 dB
Harmonic distortion	0.4%
Selectivity at 9 kHz	50 dB
General	
Power requirements	UK model : 240 V AC, 50/60 Hz AEP, West Germany, Italian model : 220 V AC, (or 240 V AC adjustable by authorized Sony personnel), 50/60 Hz US, Canadian model: 120 V AC, 60 Hz
Power consumption	10 W
Dimensions	Approx. 430×85×360 mm (w/h/d) (17×3 $\frac{3}{8}$ ×14 $\frac{1}{4}$ inches)
Weight	Approx. 4kg (8 lb 14 oz)
Accessories supplied	Remote control cord (1) Connecting cord (1) AM loop antenna (1)

TABLE OF CONTENTS

<u>Section</u>	<u>Title</u>	<u>Page</u>
	Specifications	1
	Model Identifications	2
	Safety Check-out	3
SECTION 1. GENERAL		
	1-1. Parts Identification	4
SECTION 2. ADJUSTMENTS5		
SECTION 3. DIAGRAMS		
	3-1. FM Front End (FE101) Schematic Diagram.....8	
	3-2. Semiconductor Lead Layouts.....10	
	3-3. Printed Wiring Boards.....10	
	3-4. Schematic Diagram.....13	
	3-5. IC Block Diagrams.....17	
SECTION 4. EXPLODED VIEW 18		
SECTION 5. ELECTRICAL PARTS LIST 20		

- MODEL IDENTIFICATIONS -

AEP, Italian Model

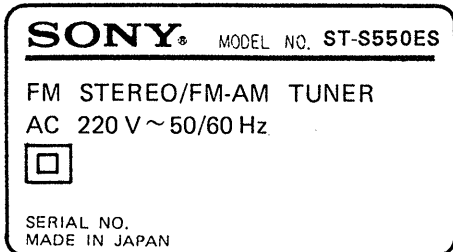

UK Model

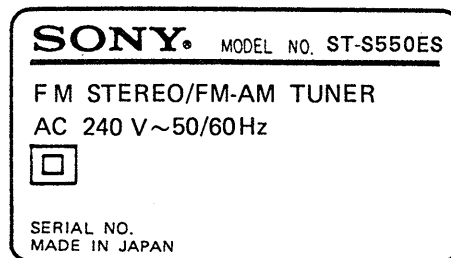

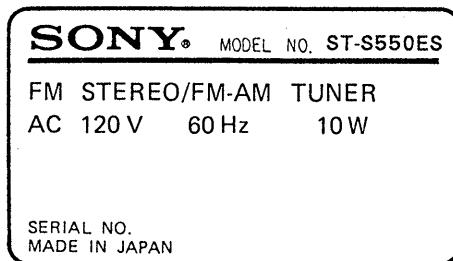

US, Canadian Model

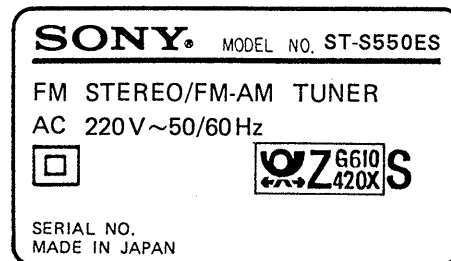

West Germany Model



SAFETY-RELATED COMPONENT WARNING!!

COMPONENTS IDENTIFIED BY MARK  OR DOTTED LINE WITH MARK  ON THE SCHEMATIC DIAGRAMS AND IN THE PARTS LIST ARE CRITICAL TO SAFE OPERATION. REPLACE THESE COMPONENTS WITH SONY PARTS WHOSE PART NUMBERS APPEAR AS SHOWN IN THIS MANUAL OR IN SUPPLEMENTS PUBLISHED BY SONY.

ATTENTION AU COMPOSANT AYANT RAPPORT À LA SÉCURITÉ!

LES COMPOSANTS IDENTIFIÉS PAR UNE MARQUE  SUR LES DIAGRAMMES SCHÉMATIQUES ET LA LISTE DES PIÈCES SONT CRITIQUES POUR LA SÉCURITÉ DE FONCTIONNEMENT. NE REMPLACER CES COMPOSANTS QUE PAR DES PIÈCES SONY DONT LES NUMÉROS SONT DONNÉS DANS CE MANUEL OU DANS LES SUPPLÉMENTS PUBLIÉS PAR SONY.

SAFETY CHECK-OUT

After correcting the original service problem, perform the following safety check before releasing the set to the customer:

Check the antenna terminals, metal trim, "metallized" knobs, screws, and all other exposed metal parts for AC leakage. Check leakage as described below.

LEAKAGE TEST

The AC leakage from any exposed metal part to earth ground and from all exposed metal parts to any exposed metal part having a return to chassis, must not exceed 0.5 mA (500 microampers). Leakage current can be measured by any one of three methods.

1. A commercial leakage tester, such as the Simpson 229 or RCA WT-540A. Follow the manufacturers' instructions to use these instruments.
2. A battery-operated AC milliammeter. The Data Precision 245 digital multimeter is suitable for this job.
3. Measuring the voltage drop across a resistor by means of a VOM or battery-operated AC voltmeter. The "limit" indication is 0.75 V, so analog meters must have an accurate low-voltage scale. The Simpson 250 and Sanwa SH-63Trd are examples of a passive VOM that is suitable. Nearly all battery operated digital multimeters that have a 2 V AC range are suitable. (See Fig. A)

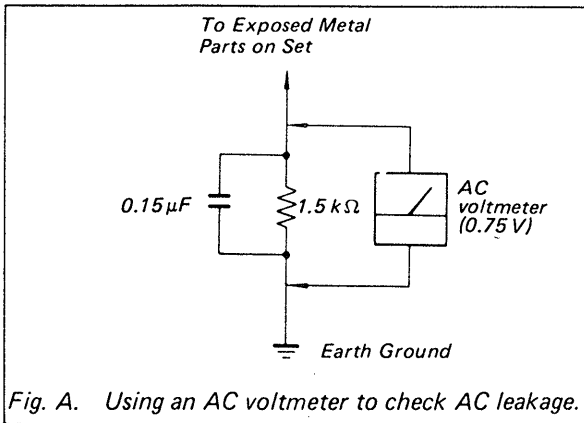
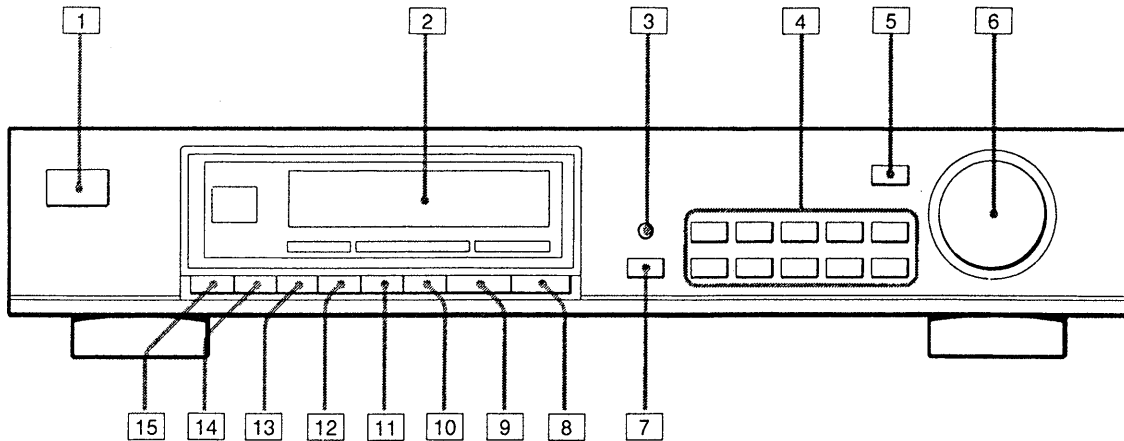

Fig. A. Using an AC voltmeter to check AC leakage.

SECTION 1 GENERAL

1-1. PARTS IDENTIFICATION



- | | |
|--|--|
| <p>1 POWER switch</p> <p>2 Display window</p> <p>3 DISPLAY button</p> <p>4 Preset buttons</p> <p>5 PRESET/TUNING button</p> <p>6 TUNING/CHARACTER knob</p> <p>7 SHIFT button</p> <p>8 MEMORY button</p> <p>9 FM/MW/LW button (AEP, UK, West Germany, Italian model)
FM/AM button (US, Canadian model)</p> <p>10 TUNE MODE button</p> | <p>11 FM MODE button</p> <p>Auto stereo: Normally, select this mode (by making the HIGH BLEND and MONO indicators disappear from the display window) when you tune in a strong FM broadcast.</p> <p>HI-BLEND: Select this position when the high-frequency sound is noisy in the FM band. The high-frequency noise will be reduced.</p> <p>MONO: Select this position when you tune in a very weak or noisy FM station. Although the sound will come out in monaural, the noise will be greatly reduced.</p> <p>12 MUTING button</p> <p>13 IF (intermediate frequency) BAND button</p> <p>14 ANT ATT (antenna attenuator) button</p> <p>15 CHARACTER button</p> |
|--|--|

SECTION 2 ADJUSTMENTS

• Refer to Adjustment Location on page 7.

Note : As a front-end (FE101, FE201, etc.) is difficult to repair if faulty, replace it with new one.

FM SECTION

• Standard Setting of FM Stereo RF Signal Generator.

	STEREO STANDARD SIGNAL	MONAURAL STANDARD SIGNAL
US, Canadian	Carrier frequency : 98MHz Modulation : Audio 1kHz, 33.75kHz deviation (45%) Sub-channel 38kHz, 33.75kHz deviation (45%) Pilot 19kHz, 7.5kHz deviation (10%)	98MHz 1kHz, 75kHz deviation (100%)
AEP, UK WG, IT	Carrier frequency : 98MHz Modulation : Audio 1kHz, 16.25kHz deviation (40.6%) Sub-channel 38kHz, 16.25kHz deviation (40.6%) Pilot 19kHz, 7.5kHz deviation (18.8%)	98MHz 1kHz, 40kHz deviation (100%)

FM Discriminator Adjustment (NULL and MONO Distortion)

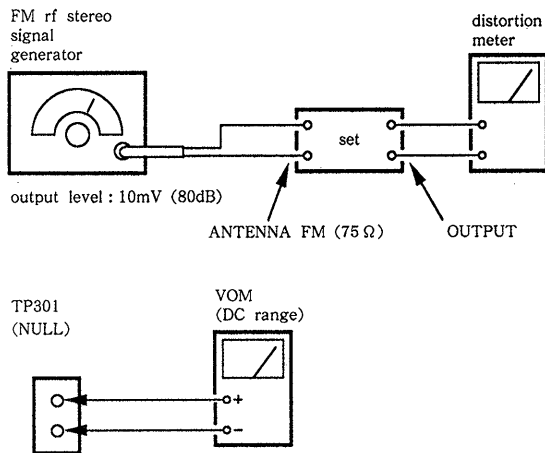

Procedure :

1. Tune the set to 98MHz.
2. Adjust T301 for 0V reading on the VOM,.....NULL
3. Adjust T302 for a minimum reading on the distortion meter,..... MONO Distortion
4. Repeat the adjustments of 2 and 3 several times.

Note : When replacing the ceramic filter, perform this alignment.

FM Stereo Distortion Adjustment

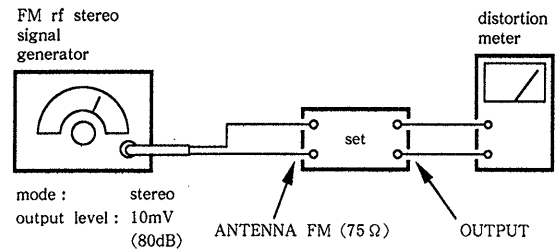

Procedure :

1. Tune the set to 98MHz.
2. Adjust T1 in FE101 for a minimum reading on the distortion meter.

FM Stereo Indication Lighting Level Adjustment

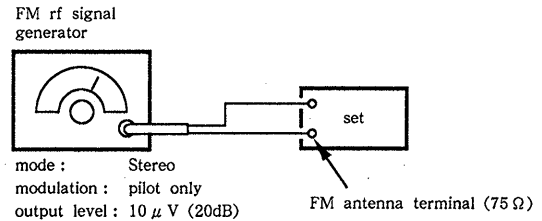

Procedure :

1. Tune the set to 98MHz.
2. Adjust RV301 to the place where STEREO indication lights.

FM Muting Level Adjustment

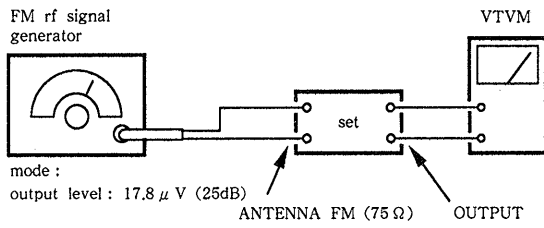

Procedure :

1. Tune the set to 98MHz.
2. Push the MUTING switch and put on the light the "MUTING" indicator in the fluorescent display.
3. Set SSG output level to 17.8 μV (25dB).
4. Adjust RV303 so that the reading of VTVM becomes within 14.1 μV (23dB) — 22.4 μV (27dB).

FM Signal Level Adjustment

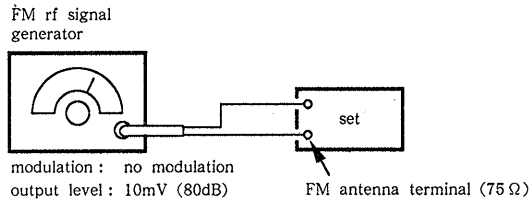

Procedure :

1. Tune the set to 98MHz.
2. Adjust RV901 to the place where level 10 in the signal strength indicator turns from dark to light.

FM Stereo Separation Adjustment

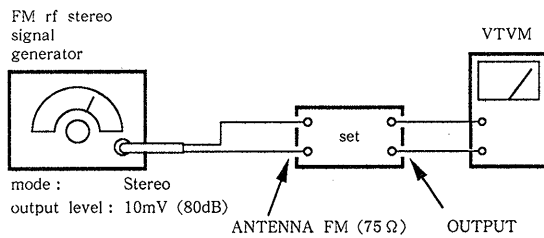

Procedure :

FM stereo signal generator output channel	VTVM connection	VTVM reading (dB)
L-CH	L-CH	Ⓐ
R-CH	L-CH	Ⓑ Adjust RV401 for minimum reading.
R-CH	R-CH	Ⓒ
L-CH	R-CH	Ⓓ Adjust RV401 for minimum reading.

L-CH Stereo separation : Ⓐ - Ⓑ

R-CH Stereo separation : Ⓒ - Ⓓ

The separation of both channels should be equal.

FM Narrow Distortion Adjustment

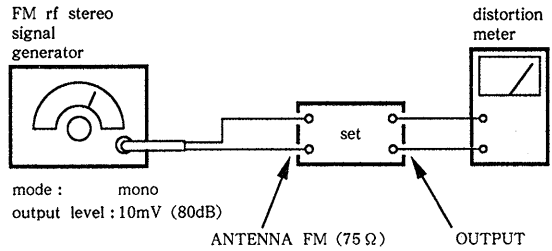

Procedure :

1. Tune the set to 98MHz.
2. Push the IF BAND switch and put on the light the "NARROW" indicator in the fluorescent display.
3. Adjust RV162 for a minimum reading on the distortion meter.

FM Narrow Gain Adjustment

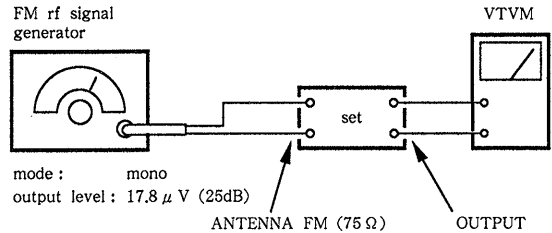

Procedure :

1. Turn the set to 98MHz.
2. Push the IF BAND switch and put on the light the "NARROW" indicator in the fluorescent display.
3. Set SSG output level to 17.8 μV (25dB).
4. Adjust RV161 so that the reading on VTVM becomes within 14.1 μV (23dB) — 22.4 μV (27dB).

AM SECTION

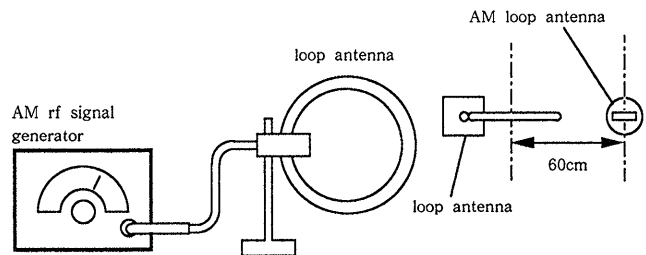

30% amplitude modulation by 400Hz signal

Carrier frequency :
 US, Canadian model: 1,000kHz
 AEP, UK, WG, IT model : 216kHz (LW Band)

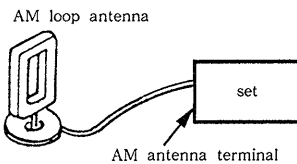

$dB \mu/m = (SSG \text{ output level}) - 26dB$

AM Signal Level Adjustment

Procedure :

1. Set SSG output level so that antenna input level of the set becomes 5.0mV (74dB).
2. Adjust RV302 to the place where level 5 in the signal strength indicator turns from dark to light.

Adjustment Location : Main Board

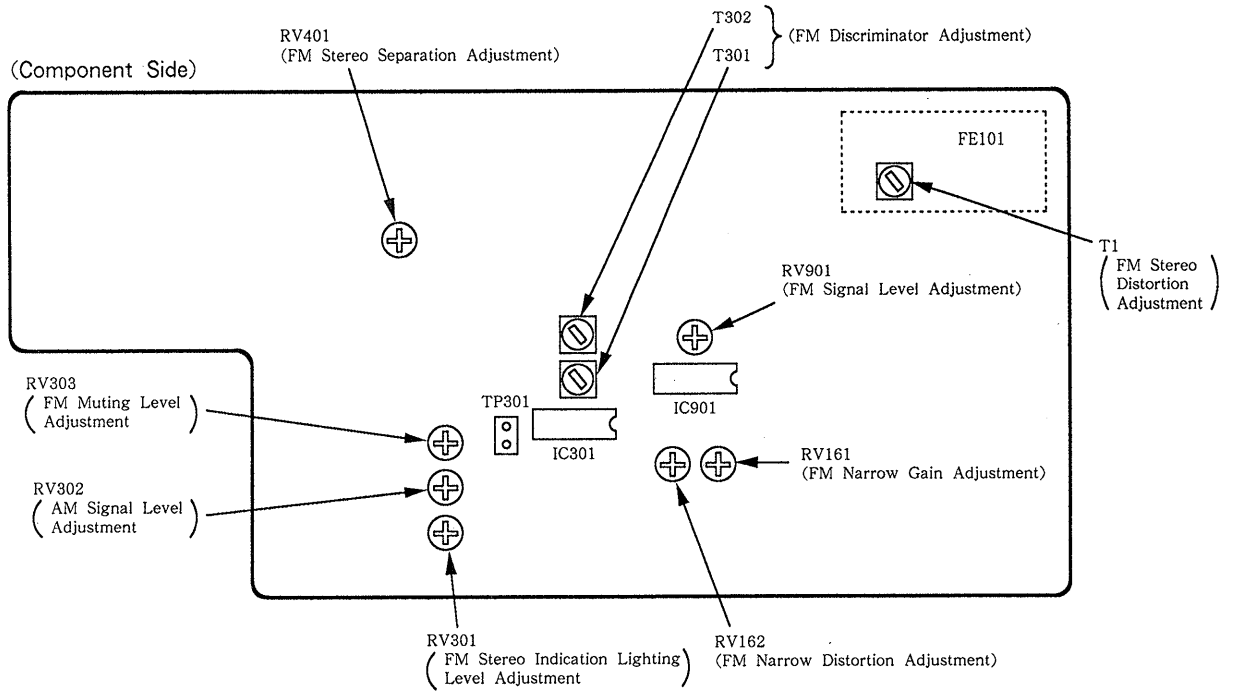

SECTION 3 DIAGRAMS

3-1. FM FRONT END (FE101) SCHEMATIC DIAGRAM

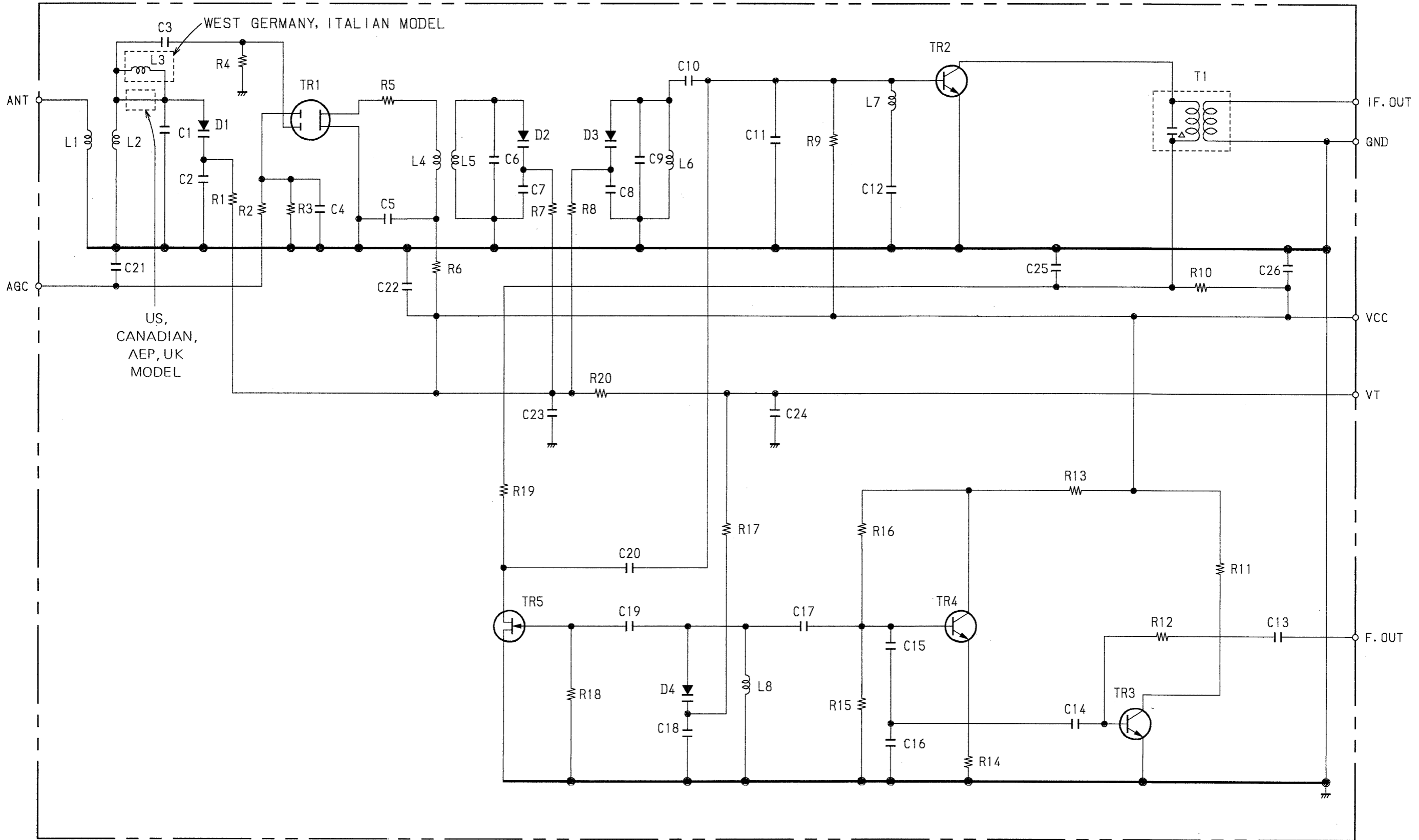

3-3. PRINTED WIRING BOARDS

3-2. SEMICONDUCTOR LEAD LAYOUTS

• SEMICONDUCTOR LOCATION

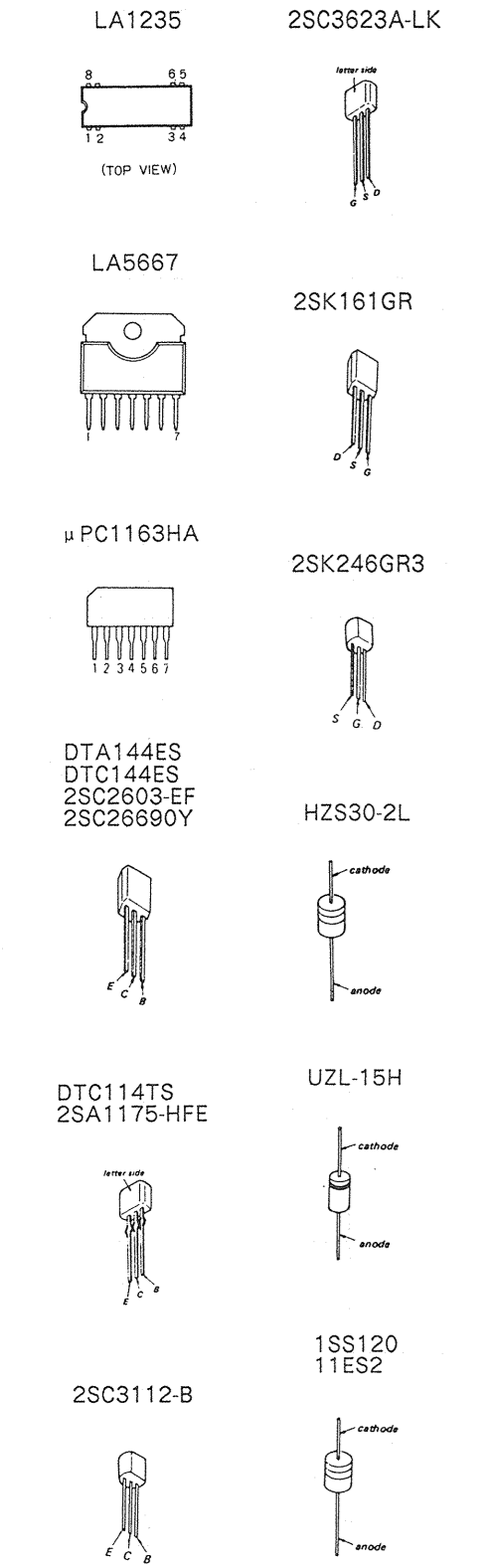

Ref. No.	Location	Ref. No.	Location
IC161	G-6	Q452	D-10
IC301	E-8	Q601	D-2
IC302	C-8	Q602	D-2
IC401	C-9	Q603	E-2
IC501	B-6	Q604	E-2
IC601	E-3	D151	D-2
IC701	I-10	D201	G-4
IC901	E-6	D401	B-9
		D501	B-6
Q101	E-6	D502	B-6
Q102	E-6		
Q103	F-6	D503	B-6
Q104	F-6	D504	B-5
Q105	D-4	D505	D-11
		D506	B-5
Q106	D-4	D701	J-14
Q107	D-4		
Q151	D-2	D702	I-8
Q163	F-6	D703	I-6
Q164	F-6	D705	I-4
		D706	I-4
Q165	F-6	D707	I-4
Q166	F-6		
Q167	F-6	D709	I-5
Q201	G-3	D710	I-5
Q202	G-3	D711	I-4
		D712	I-4
Q203	F-4	D713	I-4
Q204	G-3		
Q205	G-3	D714	I-3
Q206	F-3	D715	I-3
Q207	F-2	D716	I-4
		D717	I-4
Q208	F-4	D718	I-4
Q209	F-4		
Q301	F-8	D719	I-4
Q302	F-9	D720	I-14
Q401	B-6	D801	B-11
		D901	E-10
Q402	B-8		
Q403	B-8		
Q451	D-9		

Note :

- : parts extracted from the component side.
- ⊙ : Pattern on the side which is seen.

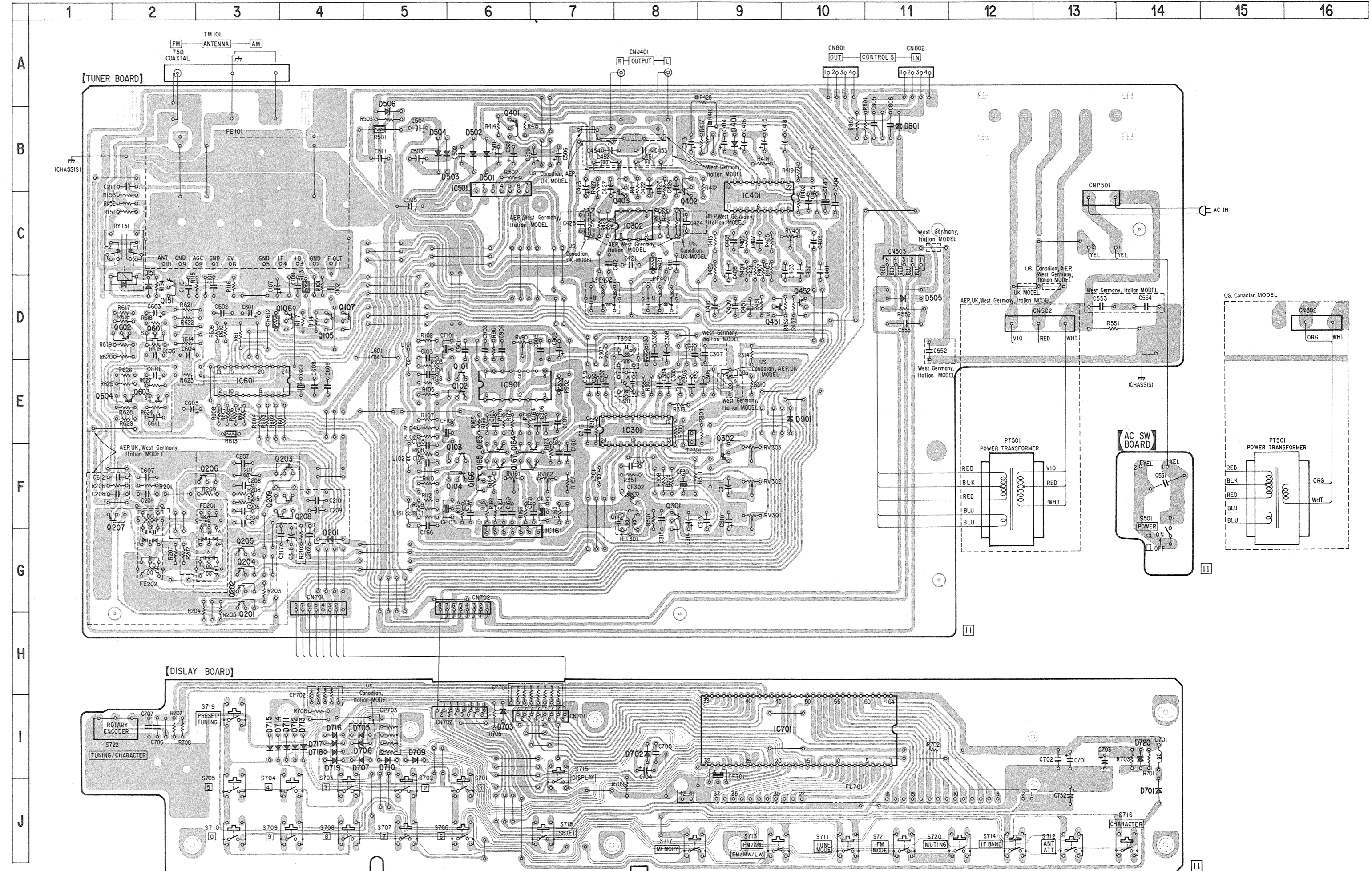

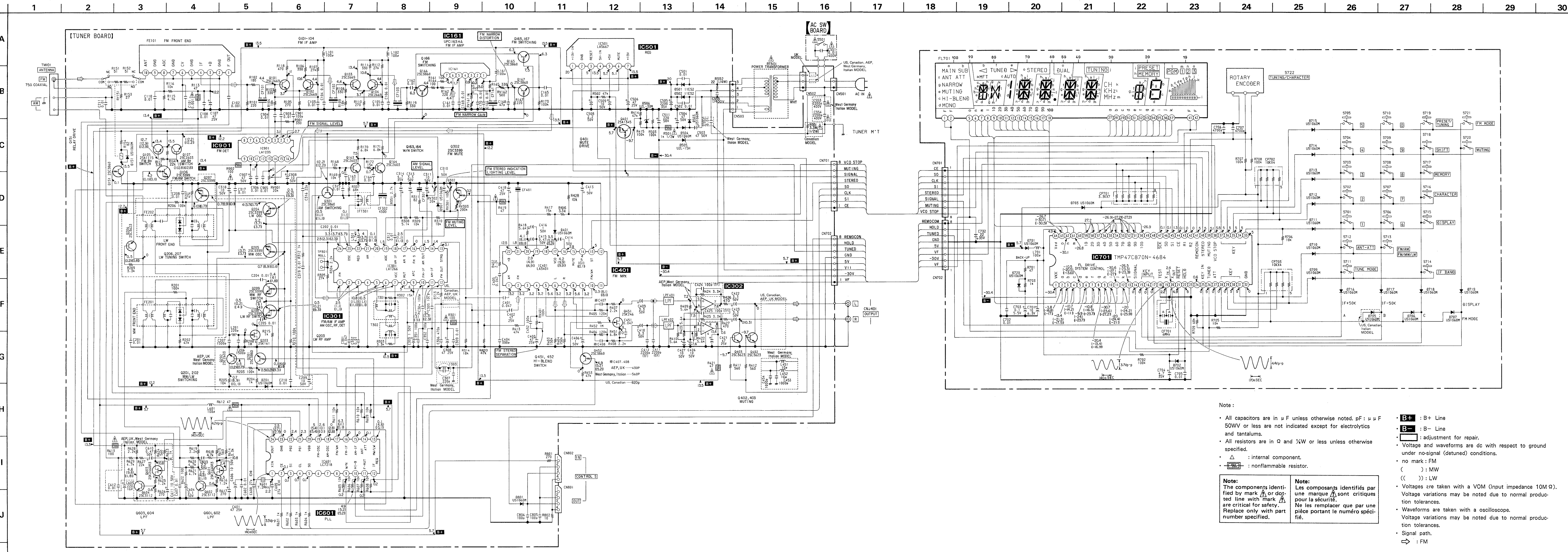

Note:

- All capacitors are in μF unless otherwise noted. pF: μF 50WV or less are not indicated except for electrolytics and tantalums.
- All resistors are in Ω and $\frac{1}{4}W$ or less unless otherwise specified.
- Δ : internal component.
- \square : nonflammable resistor.

Note:

- The components identified by mark Δ or dotted line with mark Δ are critical for safety. Replace only with part number specified.
- Les composants identifiés par une marque Δ sont critiques pour la sécurité. Ne les remplacer que par une pièce portant le numéro spécifié.

Legend:

- B+**: B+ Line
- B-**: B- Line
- \square : adjustment for repair.
- Voltage and waveforms are dc with respect to ground under no-signal (detuned) conditions.
- no mark: FM
- (): MW
- (()): LW
- Voltagés are taken with a VOM (Input impedance 10M Ω). Voltage variations may be noted due to normal production tolerances.
- Waveforms are taken with a oscilloscope. Voltage variations may be noted due to normal production tolerances.
- Signal path.
- \Rightarrow : FM

• IC BLOCK DIAGRAMS

IC161 μ PC1163HA

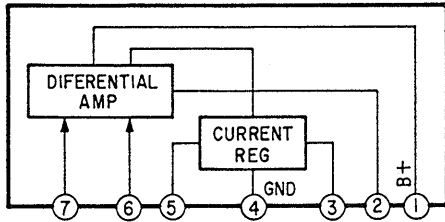

IC401 LA3401

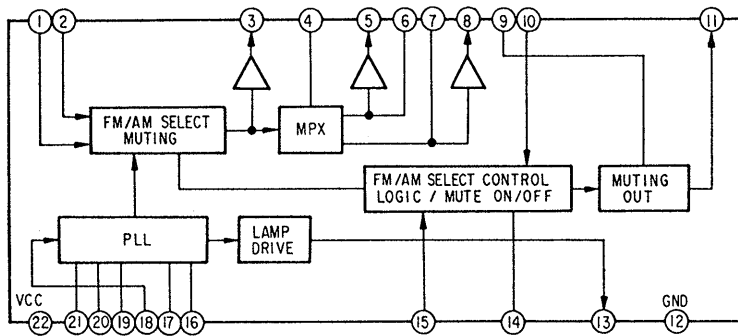

IC501 LA5667

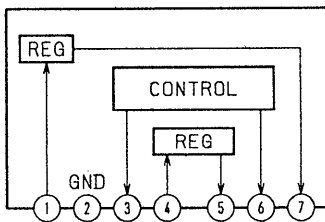

IC601 LC7218

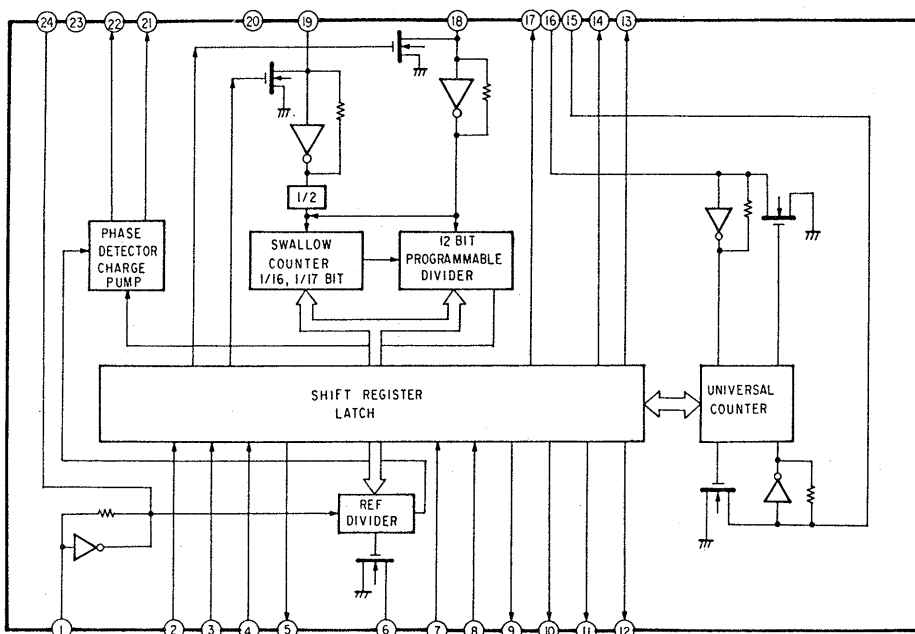

IC301 LA1266

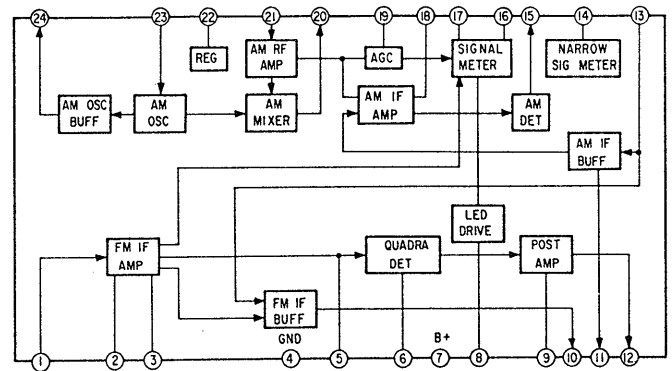

IC901 LA1235

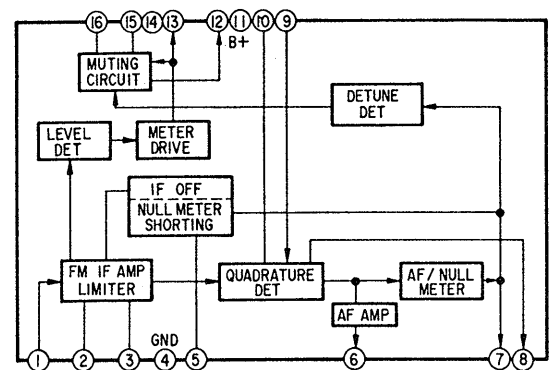

SECTION 4 EXPLODED VIEWS

NOTE:

- The mechanical parts with no reference number in the exploded views are not supplied.
- The construction parts of an assembled part are indicated with a collation number in the remark column.
- Items marked "*" are not stocked since they are seldom required for routine service. Some delay should be anticipated when ordering these items.

- Due to standardization, parts with part number suffix -XX and -X may be different from the parts specified in the components used on the set.

Color Indication of Appearance Parts
Example:

(RED) ... KNOB, BALANCE (WHITE)





Cabinet's Color



Parts' Color

- US : USA
- CND : Canadian
- WG : West Germany
- IT : Italian
- Gray type : Only AEP and WG

The components identified by mark  or dotted line with mark  are critical for safety. Replace only with part number specified.

Les composants identifiés par une marque  sont critiques pour la sécurité. Ne les remplacer que par une pièce portant le numéro spécifié.

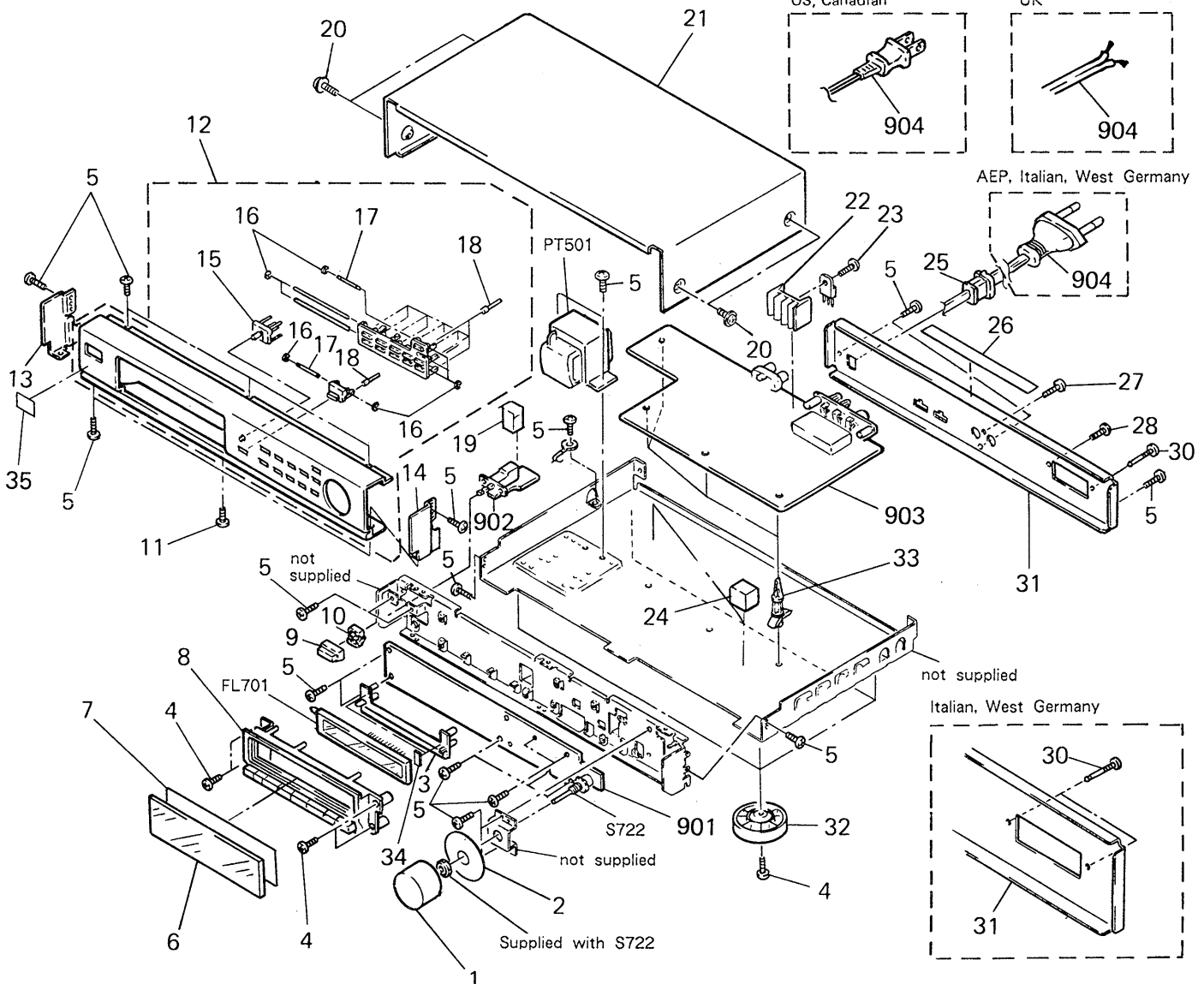

No.	Part No.	Description	Remarks	No.	Part No.	Description	Remarks
1	4-911-359-01 4-911-359-11	(BLK)...KNOB (GRY)...KNOB		21	4-923-420-71 4-923-420-81	(BLK)...CASE (GRY)...CASE	
2	*4-911-372-01	CLOTH, BLIND		22	*4-921-402-11	HEAT SINK	
3	*4-925-125-11	HOLDER, FL TUBE		23	7-682-548-09	SCREW +B 3X8	
4	7-682-548-09	SCREW +BVTT 3X8 (S)		24	9-911-830-XX	CUSHION	
5	7-682-547-09	SCREW +BVTT 3X6 (S)		25	*3-703-244-00	BUSHING (2104), CORD	
6	4-923-451-01	WINDOW, DISPLAY		26	*4-926-828-11	PLATE, LIGHT INTERCEPTION	
7	4-935-832-01	PLATE, ORNAMENTAL		27	7-621-849-00	SCREW, TAPPING	
8	X-4886-049-1 X-4886-050-1 X-4941-004-1	(BLK:US,CND)....ESCUTCHEON ASSY, PANEL (BLK:AEP,UK,WG,IT) ...ESCUTCHEON ASSY, PANEL (GRY).....ESCUTCHEON ASSY, PANEL		28	7-685-646-79	(BLK:US,CND,AEP,UK)...SCREW +BVTP 3X8 TYPE2 N-S	
9	4-908-046-01 4-908-046-61	(BLK)...KNOB, SQUARE (GRY)...KNOB, SQUARE		30	3-704-242-01	SCREW, TERMINAL, + BVTP CLAW	
10	4-864-307-00 4-881-725-01	(BLK)...RING (GRY)...RING		31	4-935-817-01	PANEL, BACK	
11	7-682-547-09	SCREW +BV 3X6, S TIGHT		32	X-3304-944-1	FOOT ASSY	
12	A-4323-611-A A-4323-614-A A-4323-738-A	(BLK:US,CND,UK)...PANEL ASSY, FRONT (BLK:AEP,WG,IT)...PANEL ASSY, FRONT (GRY).....PANEL ASSY, FRONT		33	*4-924-098-31	HOLDER, PC BOARD	
13	*4-911-361-01 *4-911-361-11	(BLK)...PLATE (LEFT), ORNAMENTAL (GRY)...PLATE (LEFT), ORNAMENTAL		34	*3-684-371-02	CUSHION	
14	*4-911-362-01 *4-911-362-11	(BLK)...PLATE (RIGHT), ORNAMENTAL (GRY)...PLATE (RIGHT), ORNAMENTAL		35	*3-703-710-41	STICKER, SONY SYMBOL (12)	
15	X-4886-042-1 X-4941-007-1	(BLK)...BUTTON (A) ASSY (GRY)...BUTTON (A) ASSY		36	X-4928-106-3	(US)...PANEL (LEFT) ASSY, SIDE (WOOD)	
16	7-624-104-04	STOP RING 2.0, TYPE -E		37	X-4928-107-3	(US)...PANEL (RIGHT) ASSY, SIDE (WOOD)	
17	4-908-088-01	SHAFT, JOINT		901	*1-635-686-11	PC BOARD, DISPLAY	
18	4-908-080-02	JOINT, KNOB		902	*1-635-687-11	PC BOARD, AC SW	
19	*4-908-872-01	(AEP,UK,WG,IT)...CUSHION		903	*A-4334-953-A *A-4334-957-A *A-4334-960-A *A-4334-963-A *A-4341-294-A	(CND)....MOUNTED PCB, TUNER (AEP)....MOUNTED PCB, TUNER (WG,IT)...MOUNTED PCB, TUNER (UK).....MOUNTED PCB, TUNER (US).....MOUNTED PCB, TUNER	
20	3-704-366-01 4-886-821-01	(GRY,US).....SCREW, M3 CASE (BLK:AEP,UK,CND,WG,IT)...SCREW, M3 CASE		904	△.1-574-383-11 △.1-574-384-11 △.1-575-105-11	(AEP,WG,IT)...CORD, POWER (UK).....CORD, POWER (US,CND).....CORD, POWER	
				FL701	1-519-602-11	INDICATOR TUBE, FLUORESCENT	
				PT501	△.1-450-105-11	(AEP,UK,WG,IT)...TRANSFORMER, POWER	
				PT501	△.1-450-106-11	(US,CND).....TRANSFORMER, POWER	
				S722	1-466-336-11	ENCODER, ROTARY (TUNING/CHARACTER)	

SECTION 5 ELECTRICAL PARTS LIST

NOTE:

- Due to standardization, replacements in the parts list may be different from the parts specified in the diagrams or the components used on the set.
- Items marked "★" are not stocked since they are seldom required for routine service. Some delay should be anticipated when ordering these items.
- If there are two or more same circuits in a set such as a stereophonic machine, only typical circuit parts may be indicated and capacitors and resistors in other same circuits may be omitted.

CAPACITORS:

MF: μ F, PF: μ μ F.

RESISTORS

- All resistors are in ohms.
- F: nonflammable

COILS

- MMH: mH, UH: μ H

SEMICONDUCTORS

In each case, U: μ , for example:

UA...: μ A..., UPA...: μ PA...,
UPC...: μ PC, UPD...: μ PD...

- US : USA
- CND : Canadian
- WG : West Germany
- IT : Italian

The components identified by mark Δ or dotted line with mark Δ are critical for safety. Replace only with part number specified.

Les composants identifiés par une marque Δ sont critiques pour la sécurité. Ne les remplacer que par une pièce portant le numéro spécifié.

Ref.No.	Part No.	Description
901	*A-4334-954-A	(US, CND)MOUNTED PCB, DISPLAY
	*A-4334-958-A	(AEP, UK, WG) ...MOUNTED PCB, DISPLAY
	*A-4334-962-A	(IT)MOUNTED PCB, DISPLAY
902	*1-635-687-11	PC BOARD, AC SW
903	*A-4334-953-A	(CND)MOUNTED PCB, TUNER
	*A-4334-957-A	(AEP)MOUNTED PCB, TUNER
	*A-4334-960-A	(WG, IT) ...MOUNTED PCB, TUNER
	*A-4334-963-A	(UK)MOUNTED PCB, TUNER
	*A-4341-294-A	(US)MOUNTED PCB, TUNER
904	Δ 1-574-383-11	(AEP, WG, IT) ...CORD, POWER
	Δ 1-574-384-11	(UK)CORD, POWER
	Δ 1-575-105-11	(US, CND)CORD, POWER
C101	1-162-294-31	CERAMIC 0.001MF 10% 50V
C102	1-162-294-31	CERAMIC 0.001MF 10% 50V
C103	1-161-379-00	CERAMIC 0.01MF 30% 16V
C104	1-161-379-00	CERAMIC 0.01MF 30% 16V
C105	1-161-379-00	CERAMIC 0.01MF 30% 16V
C106	1-161-379-00	CERAMIC 0.01MF 30% 16V
C107	1-126-022-11	ELECT 47MF 20% 25V
C108	1-161-379-00	CERAMIC 0.01MF 30% 16V
C110	1-161-379-00	CERAMIC 0.01MF 30% 16V
C161	1-161-379-00	CERAMIC 0.01MF 30% 16V
C162	1-161-379-00	CERAMIC 0.01MF 30% 16V
C163	1-161-379-00	CERAMIC 0.01MF 30% 16V
C164	1-161-379-00	CERAMIC 0.01MF 30% 16V
C165	1-161-379-00	CERAMIC 0.01MF 30% 16V
C166	1-161-379-00	CERAMIC 0.01MF 30% 16V
C168	1-162-215-31	CERAMIC 47PF 5% 50V
C169	1-161-379-00	CERAMIC 0.01MF 30% 16V
C170	1-161-379-00	CERAMIC 0.01MF 30% 16V
C201	1-161-379-00	CERAMIC 0.01MF 30% 16V
C202	1-161-379-00	CERAMIC 0.01MF 30% 16V
C204	1-161-379-00	(AEP, UK, WG, IT) ...CERAMIC 0.01MF 30% 16V
C205	1-161-379-00	(AEP, UK, WG, IT) ...CERAMIC 0.01MF 30% 16V
C206	1-161-374-11	(AEP, UK, WG, IT) ...CERAMIC 0.0015MF 30% 16V
C207	1-161-374-11	(AEP, UK, WG, IT) ...CERAMIC 0.0015MF 30% 16V
C208	1-161-379-00	(AEP, UK, WG, IT) ...CERAMIC 0.01MF 30% 16V
C209	1-126-059-11	(AEP, UK, WG, IT) ...ELECT 10MF 20% 50V
C210	1-161-379-00	(AEP, UK, WG, IT) ...CERAMIC 0.01MF 30% 16V

Ref.No.	Part No.	Description
C211	1-161-379-00	CERAMIC 0.01MF 30% 16V
C301	1-136-161-00	FILM 0.047MF 5% 50V
C302	1-161-379-00	CERAMIC 0.01MF 30% 16V
C303	1-124-791-11	ELECT 1MF 20% 50V
C304	1-162-282-31	CERAMIC 100PF 10% 50V
C305	1-162-282-31	CERAMIC 100PF 10% 50V
C306	1-130-467-00	MYLAR 470PF 5% 50V
C307	1-110-339-11	(WG, IT) ...MYLAR 220P 5% 50V
C308	1-126-022-11	ELECT 47MF 20% 25V
C309	1-161-379-00	CERAMIC 0.01MF 30% 16V
C310	1-124-791-11	ELECT 1MF 20% 50V
C311	1-126-059-11	ELECT 10MF 20% 50V
C312	1-161-379-00	CERAMIC 0.01MF 30% 16V
C313	1-123-382-00	ELECT 3.3MF 20% 50V
C314	1-126-094-11	ELECT 4.7MF 20% 35V
C315	1-161-379-00	CERAMIC 0.01MF 30% 16V
C316	1-162-207-31	CERAMIC 22PF 5% 50V
C317	1-161-379-00	CERAMIC 0.01MF 30% 16V
C318	1-126-059-11	ELECT 10MF 20% 50V
C319	1-161-379-00	CERAMIC 0.01MF 30% 16V
C351	1-162-282-31	CERAMIC 100PF 10% 50V
C352	1-162-282-31	CERAMIC 100PF 10% 50V
C401	1-136-161-00	FILM 0.047MF 5% 50V
C402	1-126-022-11	ELECT 47MF 20% 25V
C403	1-126-022-11	ELECT 47MF 20% 25V
C404	1-162-288-31	CERAMIC 330PF 10% 50V
C405	1-136-161-00	FILM 0.047MF 5% 50V
C406	1-124-791-11	ELECT 1MF 20% 50V
C407	1-104-293-11	(AEP, UK) ...POLYSTYRENE 430PF 5% 50V
C407	1-104-296-11	(WG, IT) ...POLYSTYRENE 560PF 5% 50V
C407	1-104-297-11	(US, CND) ...POLYSTYRENE 620PF 5% 50V
C408	1-104-293-11	(AEP, UK) ...POLYSTYRENE 430PF 5% 50V
C408	1-104-296-11	(WG, IT) ...POLYSTYRENE 560PF 5% 50V
C408	1-104-297-11	(US, CND) ...POLYSTYRENE 620PF 5% 50V
C409	1-123-382-00	ELECT 3.3MF 20% 50V
C410	1-123-382-00	ELECT 3.3MF 20% 50V
C411	1-130-475-00	MYLAR 0.0022MF 5% 50V
C412	1-130-475-00	MYLAR 0.0022MF 5% 50V
C413	1-124-791-11	ELECT 1MF 20% 50V
C414	1-124-791-11	ELECT 1MF 20% 50V
C415	1-124-902-00	ELECT 0.47MF 20% 50V
C416	1-124-791-11	ELECT 1MF 20% 50V
C418	1-126-022-11	ELECT 47MF 20% 25V
C421	1-126-022-11	ELECT 47MF 20% 25V
C422	1-123-382-00	ELECT 3.3MF 20% 50V
C423	1-123-382-00	ELECT 3.3MF 20% 50V

Ref.No.	Part No.	Description
C424	1-110-335-11	(AEP,WG,IT)...MYLAR 100PF 5% 50V
C425	1-110-335-11	(AEP,WG,IT)...MYLAR 100PF 5% 50V
C426	1-126-059-11	ELECT 10MF 20% 50V
C427	1-126-059-11	ELECT 10MF 20% 50V
C451	1-136-161-00	FILM 0.047MF 5% 50V
C452	1-110-335-11	MYLAR 100PF 5% 50V
C453	1-130-471-00	(WG,IT)...MYLAR 0.001MF 5% 50V
C454	1-130-471-00	(WG,IT)...MYLAR 0.001MF 5% 50V
C501	1-101-004-00	CERAMIC 0.01MF 50V
C502	1-101-004-00	CERAMIC 0.01MF 50V
C503	1-124-910-11	ELECT 47MF 20% 50V
C504	1-124-910-11	ELECT 47MF 20% 50V
C505	1-124-602-00	ELECT 220MF 20% 35V
C506	1-126-022-11	ELECT 47MF 20% 25V
C508	1-124-925-11	ELECT 2.2MF 20% 50V
C509	1-126-059-11	ELECT 10MF 20% 50V
C511	1-124-911-11	ELECT 220MF 20% 50V
C551	△ 1-161-744-00	CERAMIC 0.01MF 400V
C552	1-101-004-00	(WG,IT)...CERAMIC 0.01MF 50V
C553	△ 1-161-742-00	(WG,IT)...CERAMIC 0.0022MF 20% 400V
C554	△ 1-161-742-00	(WG,IT)...CERAMIC 0.0022MF 20% 400V
C555	1-130-789-00	FILM 1MF 5% 100V
C601	1-126-022-11	ELECT 47MF 20% 25V
C602	1-161-379-00	CERAMIC 0.01MF 30% 16V
C603	1-124-925-11	ELECT 2.2MF 20% 50V
C604	1-124-463-00	ELECT 0.1MF 20% 50V
C605	1-126-024-11	ELECT 220MF 20% 16V
C606	1-126-059-11	ELECT 10MF 20% 50V
C607	1-161-379-00	CERAMIC 0.01MF 30% 16V
C608	1-102-961-00	CERAMIC 27PF 5% 50V
C609	1-102-961-00	CERAMIC 27PF 5% 50V
C610	1-124-902-00	(AEP,UK,WG,IT)...ELECT 0.47MF 20% 50V
C611	1-126-059-11	(AEP,UK,WG,IT)...ELECT 10MF 20% 50V
C612	1-161-379-00	(AEP,UK,WG,IT)...CERAMIC 0.01MF 30% 16V
C701	1-131-377-00	TANTALUM 10MF 10% 6.3V
C702	1-161-379-00	CERAMIC 0.01MF 30% 16V
C703	1-125-548-11	DOUBLE LAYERS 0.1F 5.5V
C704	1-126-094-11	ELECT 4.7MF 20% 35V
C705	1-161-379-00	CERAMIC 0.01MF 30% 16V
C706	1-161-377-00	CERAMIC 0.0047MF 30% 16V
C707	1-161-377-00	CERAMIC 0.0047MF 30% 16V
C732	1-123-357-00	ELECT 22MF 20% 35V
C805	1-162-282-31	CERAMIC 100PF 10% 50V
C806	1-162-282-31	CERAMIC 100PF 10% 50V
C901	1-162-282-31	CERAMIC 100PF 10% 50V
C903	1-161-379-00	CERAMIC 0.01MF 30% 16V
C904	1-161-379-00	CERAMIC 0.01MF 30% 16V
C905	1-161-379-00	CERAMIC 0.01MF 30% 16V
C906	1-161-379-00	CERAMIC 0.01MF 30% 16V
C907	1-124-910-11	ELECT 47MF 20% 50V
C908	1-126-059-11	ELECT 10MF 20% 50V
CF101	1-567-389-11	(AEP,UK,WG,IT)...FILTER, CERAMIC
CF101	1-567-393-11	(US,CND).....FILTER, CERAMIC
CF102	1-567-389-11	(AEP,UK,WG,IT)...FILTER, CERAMIC
CF102	1-567-393-11	(US,CND).....FILTER, CERAMIC
CF103	1-567-389-11	(AEP,UK,WG,IT)...FILTER, CERAMIC
CF103	1-567-393-11	(US,CND).....FILTER, CERAMIC
CF161	1-567-389-11	(US,CND).....FILTER, CERAMIC
CF161	1-577-299-31	(AEP,UK,WG,IT)...FILTER, CERAMIC

Ref.No.	Part No.	Description
CF301	1-527-981-00	FILTER, CERAMIC
CF302	1-527-826-00	FILTER, CERAMIC
CF401	1-567-250-11	OSCILLATOR, CERAMIC (18.95kHz)
CF701	1-577-360-11	VIBRATOR, CERAMIC (6MHz)
CN501	*1-564-321-00	PIN, CONNECTOR 2P
CN502	*1-564-321-00	(CND).....PIN, CONNECTOR 2P
CN502	*1-564-687-11	(AEP,UK,WG,IT)...PIN, CONNECTOR 3P
CN502	*1-535-139-00	(US).....BASEPOST 19MM(10MM PITCH) 2P
CN503	*1-560-063-00	PIN, CONNECTOR 5P
CN801	1-564-980-11	PIN, CONNECTOR 4P
CN802	1-564-980-11	PIN, CONNECTOR 4P
CNJ401	*1-568-250-21	JACK, PIN 2P (OUTPUT L/R)
CP701	1-233-185-11	COMPOSITION CIRCUIT BLOCK
CP702	1-233-125-11	COMPOSITION CIRCUIT BLOCK
D151	8-719-912-20	DIODE 1SS120
D201	8-719-912-20	(AEP,UK,WG,IT)...DIODE 1SS120
D401	8-719-912-20	DIODE 1SS120
D501	8-719-200-82	DIODE 11ES2
D502	8-719-200-82	DIODE 11ES2
D503	8-719-912-20	DIODE 1SS120
D504	8-719-912-20	DIODE 1SS120
D505	8-719-001-94	DIODE UZL-15H
D506	8-719-934-22	DIODE HZS30-2L
D701	8-719-912-20	DIODE 1SS120
D702	8-719-912-20	DIODE 1SS120
D703	8-719-912-20	DIODE 1SS120
D705	8-719-912-20	(US,CND,IT)...DIODE 1SS120
D706	8-719-912-20	DIODE 1SS120
D707	8-719-912-20	DIODE 1SS120
D709	8-719-912-20	DIODE 1SS120
D710	8-719-912-20	DIODE 1SS120
D711	8-719-912-20	DIODE 1SS120
D712	8-719-912-20	DIODE 1SS120
D713	8-719-912-20	DIODE 1SS120
D714	8-719-912-20	DIODE 1SS120
D715	8-719-912-20	DIODE 1SS120
D716	8-719-912-20	DIODE 1SS120
D717	8-719-912-20	DIODE 1SS120
D718	8-719-912-20	DIODE 1SS120
D719	8-719-912-20	DIODE 1SS120
D720	8-719-912-20	DIODE 1SS120
D801	8-719-912-20	DIODE 1SS120
D901	8-719-912-20	DIODE 1SS120
FE101	1-463-857-11	(WG,IT)...FRONT END (FM)
FE101	1-465-219-11	(US,CND,AEP,UK)...FRONT END
FE201	1-236-461-11	(US,CND).....ENCAPSULATED COMPONENT
FE201	1-236-462-11	(AEP,UK,WG,IT)...ENCAPSULATED COMPONENT
FE202	1-236-463-11	(AEP,UK,WG,IT)...ENCAPSULATED COMPONENT
FL701	1-519-602-11	INDICATOR TUBE, FLUORESCENT
IC161	8-759-111-72	IC UPC1163HA
IC301	8-759-804-55	IC LA1266
IC302	8-759-945-58	IC RC4558P
IC401	8-759-801-80	IC LA3401
IC501	8-759-820-09	IC LA5667
IC601	8-759-820-91	IC LC7218

Note:
The components identified by mark **△** or dotted line with mark **△** are critical for safety. Replace only with part number specified.

Note:
Les composants identifiés par une marque **△** sont critiques pour la sécurité. Ne les remplacer que par une pièce portant le numéro spécifié.

Ref.No.	Part No.	Description
IC701	8-759-239-28	IC TMP47C870N-4684
IC901	8-759-812-35	IC LA1235
I FT301	1-404-326-00	TRANSFORMER, IF
L101	1-410-521-11	INDUCTOR 100UH
L102	1-410-521-11	INDUCTOR 100UH
L161	1-410-521-11	INDUCTOR 100UH
L201	1-410-336-11	(AEP,UK,WG,IT)...INDUCTOR 220UH
L301	1-407-500-00	INDUCTOR 4.7MMH
L451	1-410-509-11	(WG,IT)...MICRO INDUCTOR 220UH
L452	1-410-509-11	(WG,IT)...MICRO INDUCTOR 220UH
L601	1-410-521-11	INDUCTOR 100UH
L701	1-410-521-11	INDUCTOR 100UH
LPF401	1-235-164-00	FILTER, LOW PASS
LPF402	1-235-164-00	FILTER, LOW PASS
PT501A	1-450-105-11	(AEP,UK,WG,IT)...TRANSFORMER, POWER
PT501A	1-450-106-11	(US, CND).....TRANSFORMER, POWER
Q101	8-729-230-XX	TRANSISTOR 2SC26690Y
Q102	8-729-230-XX	TRANSISTOR 2SC26690Y
Q103	8-729-230-XX	TRANSISTOR 2SC26690Y
Q104	8-729-230-XX	TRANSISTOR 2SC26690Y
Q105	8-729-119-76	TRANSISTOR 2SA1175-HFE
Q106	8-729-900-89	TRANSISTOR DTC144ES
Q107	8-729-620-05	TRANSISTOR 2SC2603-EF
Q151	8-729-904-39	TRANSISTOR DTC114TS
Q163	8-729-620-05	TRANSISTOR 2SC2603-EF
Q164	8-729-620-05	TRANSISTOR 2SC2603-EF
Q165	8-729-904-39	TRANSISTOR DTC114TS
Q166	8-729-904-39	TRANSISTOR DTC114TS
Q167	8-729-904-39	TRANSISTOR DTC114TS
Q201	8-729-900-89	(AEP,UK,WG,IT)...TRANSISTOR DTC144ES
Q202	8-729-620-05	(AEP,UK,WG,IT)...TRANSISTOR 2SC2603-EF
Q203	8-729-231-21	(AEP,UK,WG,IT)...TRANSISTOR 2SK161-GR
Q204	8-729-900-89	(AEP,UK,WG,IT)...TRANSISTOR DTC144ES
Q205	8-729-900-89	(AEP,UK,WG,IT)...TRANSISTOR DTC144ES
Q206	8-729-141-30	(AEP,UK,WG,IT)...TRANSISTOR 2SC3623A-LK
Q207	8-729-900-89	(AEP,UK,WG,IT)...TRANSISTOR DTC144ES
Q208	8-729-900-89	(AEP,UK,WG,IT)...TRANSISTOR DTC144ES
Q209	8-729-900-89	(AEP,UK,WG,IT)...TRANSISTOR DTC144ES
Q301	8-729-904-39	TRANSISTOR DTC114TS
Q302	8-729-900-89	TRANSISTOR DTC144ES
Q401	8-729-900-65	TRANSISTOR DTA144ES
Q402	8-729-141-30	TRANSISTOR 2SC3623A-LK
Q403	8-729-141-30	TRANSISTOR 2SC3623A-LK
Q451	8-729-202-67	TRANSISTOR 2SK246GR3
Q452	8-729-904-39	TRANSISTOR DTC114TS
Q601	8-729-202-67	TRANSISTOR 2SK246GR3
Q602	8-729-201-84	TRANSISTOR 2SC3112-B
Q603	8-729-202-67	(AEP,UK,WG,IT)...TRANSISTOR 2SK246GR3
Q604	8-729-201-84	(AEP,UK,WG,IT)...TRANSISTOR 2SC3112-B
R101	1-259-412-11	CARBON 220 5% 1/6W
R102	1-259-410-11	CARBON 180 5% 1/6W
R103	1-259-416-11	CARBON 330 5% 1/6W
R104	1-259-458-11	CARBON 18K 5% 1/6W
R105	1-259-414-11	CARBON 270 5% 1/6W
R106	1-259-416-11	CARBON 330 5% 1/6W

Ref.No.	Part No.	Description
R107	1-259-462-11	CARBON 27K 5% 1/6W
R108	1-259-416-11	CARBON 330 5% 1/6W
R109	1-259-458-11	CARBON 18K 5% 1/6W
R110	1-259-414-11	CARBON 270 5% 1/6W
R111	1-259-416-11	CARBON 330 5% 1/6W
R112	1-259-462-11	CARBON 27K 5% 1/6W
R113	△ 1-249-401-11	CARBON 47 5% 1/4W F
R114	1-259-460-11	CARBON 22K 5% 1/6W
R115	1-259-444-11	CARBON 4.7K 5% 1/6W
R116	1-259-452-11	CARBON 10K 5% 1/6W
R117	1-259-440-11	CARBON 3.3K 5% 1/6W
R118	1-259-420-11	CARBON 470 5% 1/6W
R119	1-259-416-11	CARBON 330 5% 1/6W
R151	1-259-397-11	CARBON 51 5% 1/6W
R152	1-259-397-11	CARBON 51 5% 1/6W
R153	1-259-390-11	CARBON 27 5% 1/6W
R154	1-259-402-11	CARBON 82 5% 1/6W
R161	1-259-404-11	CARBON 100 5% 1/6W
R162	1-259-412-11	CARBON 220 5% 1/6W
R163	1-259-384-11	CARBON 15 5% 1/6W
R164	1-259-404-11	CARBON 100 5% 1/6W
R165	1-259-416-11	CARBON 330 5% 1/6W
R167	1-259-412-11	CARBON 220 5% 1/6W
R168	1-259-452-11	CARBON 10K 5% 1/6W
R169	1-259-452-11	CARBON 10K 5% 1/6W
R170	1-259-448-11	CARBON 6.8K 5% 1/6W
R171	1-259-448-11	CARBON 6.8K 5% 1/6W
R172	1-259-456-11	CARBON 15K 5% 1/6W
R173	1-259-476-11	CARBON 100K 5% 1/6W
R201	1-259-476-11	CARBON 100K 5% 1/6W
R202	1-259-468-11	CARBON 47K 5% 1/6W
R203	1-259-476-11	(AEP,UK,WG,IT)...CARBON 100K 5% 1/6W
R204	1-259-428-11	(AEP,UK,WG,IT)...CARBON 1K 5% 1/6W
R205	1-259-452-11	(AEP,UK,WG,IT)...CARBON 10K 5% 1/6W
R206	1-259-476-11	(AEP,UK,WG,IT)...CARBON 100K 5% 1/6W
R207	1-259-468-11	(AEP,UK,WG,IT)...CARBON 47K 5% 1/6W
R208	1-259-500-11	(AEP,UK,WG,IT)...CARBON 1M 5% 1/6W
R209	1-259-440-11	(AEP,UK,WG,IT)...CARBON 3.3K 5% 1/6W
R210	1-259-476-11	(AEP,UK,WG,IT)...CARBON 100K 5% 1/6W
R215	1-259-428-11	(AEP,UK,WG,IT)...CARBON 1K 5% 1/6W
R301	△ 1-249-405-11	CARBON 100 5% 1/4W F
R302	1-259-456-11	CARBON 15K 5% 1/6W
R303	1-259-440-11	CARBON 3.3K 5% 1/6W
R304	1-259-436-11	CARBON 2.2K 5% 1/6W
R305	1-259-462-11	CARBON 27K 5% 1/6W
R307	1-259-472-11	CARBON 68K 5% 1/6W
R308	1-259-445-11	CARBON 5.1K 5% 1/6W
R309	1-259-452-11	CARBON 10K 5% 1/6W
R310	1-259-452-11	CARBON 10K 5% 1/6W
R311	1-259-402-11	CARBON 82 5% 1/6W
R312	1-259-428-11	CARBON 1K 5% 1/6W
R313	1-259-436-11	CARBON 2.2K 5% 1/6W
R314	1-259-458-11	CARBON 18K 5% 1/6W
R351	1-259-438-11	CARBON 2.7K 5% 1/6W
R402	1-259-436-11	CARBON 2.2K 5% 1/6W
R403	1-259-480-11	CARBON 150K 5% 1/6W
R404	1-259-480-11	CARBON 150K 5% 1/6W

Note:
The components identified by mark △ or dotted line with mark △ are critical for safety. Replace only with part number specified.

Note:
Les composants identifiés par une marque △ sont critiques pour la sécurité. Ne les remplacer que par une pièce portant le numéro spécifié.

Ref.No.	Part No.	Description	Ref.No.	Part No.	Description
R405	1-259-478-11	CARBON 120K 5% 1/6W	R626	1-259-414-11	(AEP,UK,WG,IT)...CARBON 270 5% 1/6W
R406	1-259-478-11	CARBON 120K 5% 1/6W	R627	1-259-460-11	(AEP,UK,WG,IT)...CARBON 22K 5% 1/6W
R407	1-259-436-11	CARBON 2.2K 5% 1/6W	R628	1-259-436-11	(AEP,UK,WG,IT)...CARBON 2.2K 5% 1/6W
R408	1-259-436-11	CARBON 2.2K 5% 1/6W	R629	1-259-444-11	(AEP,UK,WG,IT)...CARBON 4.7K 5% 1/6W
R409	1-259-446-11	CARBON 5.6K 5% 1/6W	R701	1-259-396-11	CARBON 47 5% 1/6W
R410	1-259-446-11	CARBON 5.6K 5% 1/6W	R702	1-259-476-11	CARBON 100K 5% 1/6W
R411	1-259-422-11	CARBON 560 5% 1/6W	R703	1-259-428-11	CARBON 1K 5% 1/6W
R412	1-259-422-11	CARBON 560 5% 1/6W	R705	1-259-452-11	CARBON 10K 5% 1/6W
R413	1-259-468-11	CARBON 47K 5% 1/6W	R706	1-259-452-11	CARBON 10K 5% 1/6W
R414	1-259-468-11	CARBON 47K 5% 1/6W	R707	1-259-476-11	CARBON 100K 5% 1/6W
R415	1-259-476-11	CARBON 100K 5% 1/6W	R708	1-259-476-11	CARBON 100K 5% 1/6W
R416	1-259-440-11	CARBON 3.3K 5% 1/6W	R709	1-259-472-11	CARBON 68K 5% 1/6W
R417	1-259-456-11	CARBON 15K 5% 1/6W	R801	1-259-414-11	CARBON 270 5% 1/6W
R418	1-259-446-11	CARBON 5.6K 5% 1/6W	R802	1-259-380-11	CARBON 10 5% 1/6W
R419	△.1-249-401-11	CARBON 47 5% 1/4W F	R901	1-259-416-11	CARBON 330 5% 1/6W
R420	1-259-468-11	CARBON 47K 5% 1/6W	R902	△.1-249-405-11	CARBON 100 5% 1/4W F
R421	△.1-249-401-11	CARBON 47 5% 1/4W F	RV161	1-237-456-11	RES, ADJ, CARBON 1K
R422	1-259-446-11	CARBON 5.6K 5% 1/6W	RV162	1-237-455-11	RES, ADJ, CARBON 500
R423	1-259-446-11	CARBON 5.6K 5% 1/6W	RV301	1-237-462-11	RES, ADJ, CARBON 100K
R424	1-259-440-11	(AEP,UK,WG,IT)...CARBON 3.3K 5% 1/6W	RV302	1-237-460-11	RES, ADJ, CARBON 20K
R425	1-259-440-11	(AEP,UK,WG,IT)...CARBON 3.3K 5% 1/6W	RV303	1-237-463-11	RES, ADJ, CARBON 200K
R426	1-259-420-11	CARBON 470 5% 1/6W	RV401	1-237-462-11	RES, ADJ, CARBON 100K
R427	1-259-420-11	CARBON 470 5% 1/6W	RV901	1-237-460-11	RES, ADJ, CARBON 20K
R428	1-259-452-11	CARBON 10K 5% 1/6W	RY151	1-515-614-11	RELAY
R451	1-259-448-11	CARBON 6.8K 5% 1/6W	S501	△1-572-267-21	SWITCH, PUSH (AC POWER)(1 KEY)(POWER)
R452	1-259-500-11	CARBON 1M 5% 1/6W	S701	1-554-303-21	SWITCH, KEY BOARD (1)
R453	1-259-468-11	CARBON 47K 5% 1/6W	S702	1-554-303-21	SWITCH, KEY BOARD (2)
R501	△.1-247-752-11	CARBON 1K 5% 1/2W F	S703	1-554-303-21	SWITCH, KEY BOARD (3)
R502	1-259-468-11	CARBON 47K 5% 1/6W	S704	1-554-303-21	SWITCH, KEY BOARD (4)
R503	1-259-476-11	CARBON 100K 5% 1/6W	S705	1-554-303-21	SWITCH, KEY BOARD (5)
R551	△.1-202-725-00	(US, CND)...SOLID 3.3M 10% 1/2W	S706	1-554-303-21	SWITCH, KEY BOARD (6)
R552	△.1-212-865-00	FUSIBLE 22 5% 1/4W F	S707	1-554-303-21	SWITCH, KEY BOARD (7)
R601	1-259-428-11	CARBON 1K 5% 1/6W	S708	1-554-303-21	SWITCH, KEY BOARD (8)
R602	1-259-428-11	CARBON 1K 5% 1/6W	S709	1-554-303-21	SWITCH, KEY BOARD (9)
R603	1-259-428-11	CARBON 1K 5% 1/6W	S710	1-554-303-21	SWITCH, KEY BOARD (0)
R604	1-259-428-11	CARBON 1K 5% 1/6W	S711	1-554-303-21	SWITCH, KEY BOARD (TUNE MODE)
R605	1-259-452-11	CARBON 10K 5% 1/6W	S712	1-554-303-21	SWITCH, KEY BOARD (ANT ATT)
R606	1-259-452-11	CARBON 10K 5% 1/6W	S713	1-554-303-21	SWITCH, KEY BOARD (FM/AM)(FM/MW/LW)
R607	1-259-452-11	CARBON 10K 5% 1/6W	S714	1-554-303-21	SWITCH, KEY BOARD (IF BAND)
R608	1-259-452-11	CARBON 10K 5% 1/6W	S715	1-571-800-11	SWITCH, KEY BOARD (DISPLAY)
R609	1-259-452-11	CARBON 10K 5% 1/6W	S716	1-554-303-21	SWITCH, KEY BOARD (CHARACTER)
R610	1-259-452-11	CARBON 10K 5% 1/6W	S717	1-554-303-21	SWITCH, KEY BOARD (MEMORY)
R611	1-259-452-11	CARBON 10K 5% 1/6W	S718	1-554-303-21	SWITCH, KEY BOARD (SHIFT)
R612	△.1-249-401-11	CARBON 47 5% 1/4W F	S719	1-554-303-21	SWITCH, KEY BOARD (PRESET/TUNING)
R613	△.1-249-405-11	CARBON 100 5% 1/4W F	S720	1-554-303-21	SWITCH, KEY BOARD (MUTING)
R614	1-259-440-11	CARBON 3.3K 5% 1/6W	S721	1-554-303-21	SWITCH, KEY BOARD (FM MODE)
R615	1-259-422-11	CARBON 560 5% 1/6W	S722	1-466-336-11	ENCODER, ROTARY (TUNING/CHARACTER)
R616	1-259-430-11	CARBON 1.2K 5% 1/6W	T301	1-404-743-11	COIL, DISCRIMINATOR
R617	1-259-414-11	CARBON 270 5% 1/6W	T302	1-404-742-11	COIL, DISCRIMINATOR
R618	1-259-444-11	CARBON 4.7K 5% 1/6W	T303	1-235-126-00	(WG,IT)...ENCAPSULATED COMPONENT
R619	1-259-436-11	CARBON 2.2K 5% 1/6W	TM101	1-537-155-11	(AEP,UK,WG,IT)...TERMINAL BOARD (ANT) (ANTENNA FM/AM)
R620	1-259-444-11	CARBON 4.7K 5% 1/6W	TM101	1-537-136-11	(US, CND).....TERMINAL BOARD (ANT) (ANTENNA FM/AM)
R621	1-259-444-11	CARBON 4.7K 5% 1/6W	TP301	*1-565-513-11	PIN, CONNECTOR 2P
R622	1-259-404-11	CARBON 100 5% 1/6W	X601	1-577-126-11	VIBRATOR, CRYSTAL (7.2MHz)
R623	1-259-428-11	(AEP,UK,WG,IT)...CARBON 1K 5% 1/6W			
R624	1-259-422-11	(AEP,UK,WG,IT)...CARBON 560 5% 1/6W			
R625	1-259-430-11	(AEP,UK,WG,IT)...CARBON 1.2K 5% 1/6W			

Note:
The components identified by mark Δ or dotted line with mark Δ are critical for safety. Replace only with part number specified.

Note:
Les composants identifiés par une marque Δ sont critiques pour la sécurité. Ne les remplacer que par une pièce portant le numéro spécifié.

ACCESSORY & PACKING MATERIAL

- 1-501-224-00 (US, CND) ...ANTENNA, FEEDER
- 1-501-369-11 (AEP, UK, IT) ..ANTENNA
- 1-501-374-11 ANTENNA, LOOP
- 1-558-233-11 CORD (WITH CONNECTOR) (SIRCS) 4P
- 1-558-271-11 CORD, CONNECTION

- 3-752-047-11 (US, CND, AEP, UK, IT) ..MANUAL, INSTRUCTION (ENGLISH/F/E/I)
- 3-752-047-41 (AEP, WG)MANUAL, INSTRUCTION (D/NL/S/P)

- *4-928-103-01 (US)CUSHION
- *4-930-835-01 CUSHION
- *4-941-350-01 (US)INDIVIDUAL CARTON
- *4-935-823-01 INDIVIDUAL CARTON

F: FRENCH D: GERMAN
E: SPANISH NL: DUTCH
I: ITALIAN S: SWEDISH
P: PORTUGUESE