

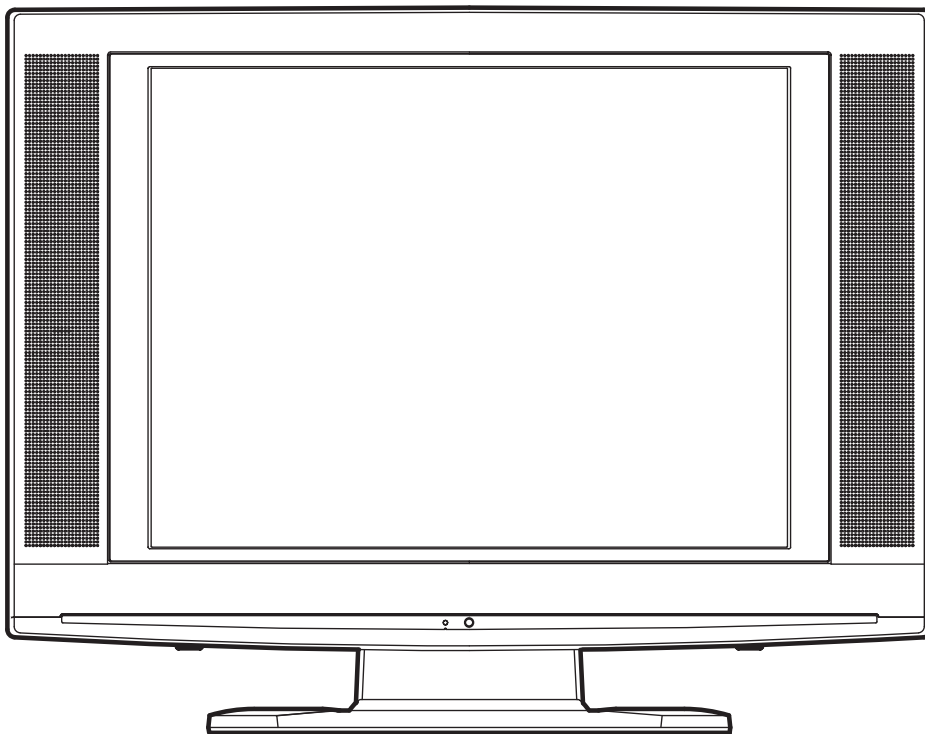

SERVICE MANUAL

**20" COLOR LCD TELEVISION
LCD-A2006/LCD-B2006/
LCD-C2006/LCD-D2006**



TV Cable Wiring Diagram

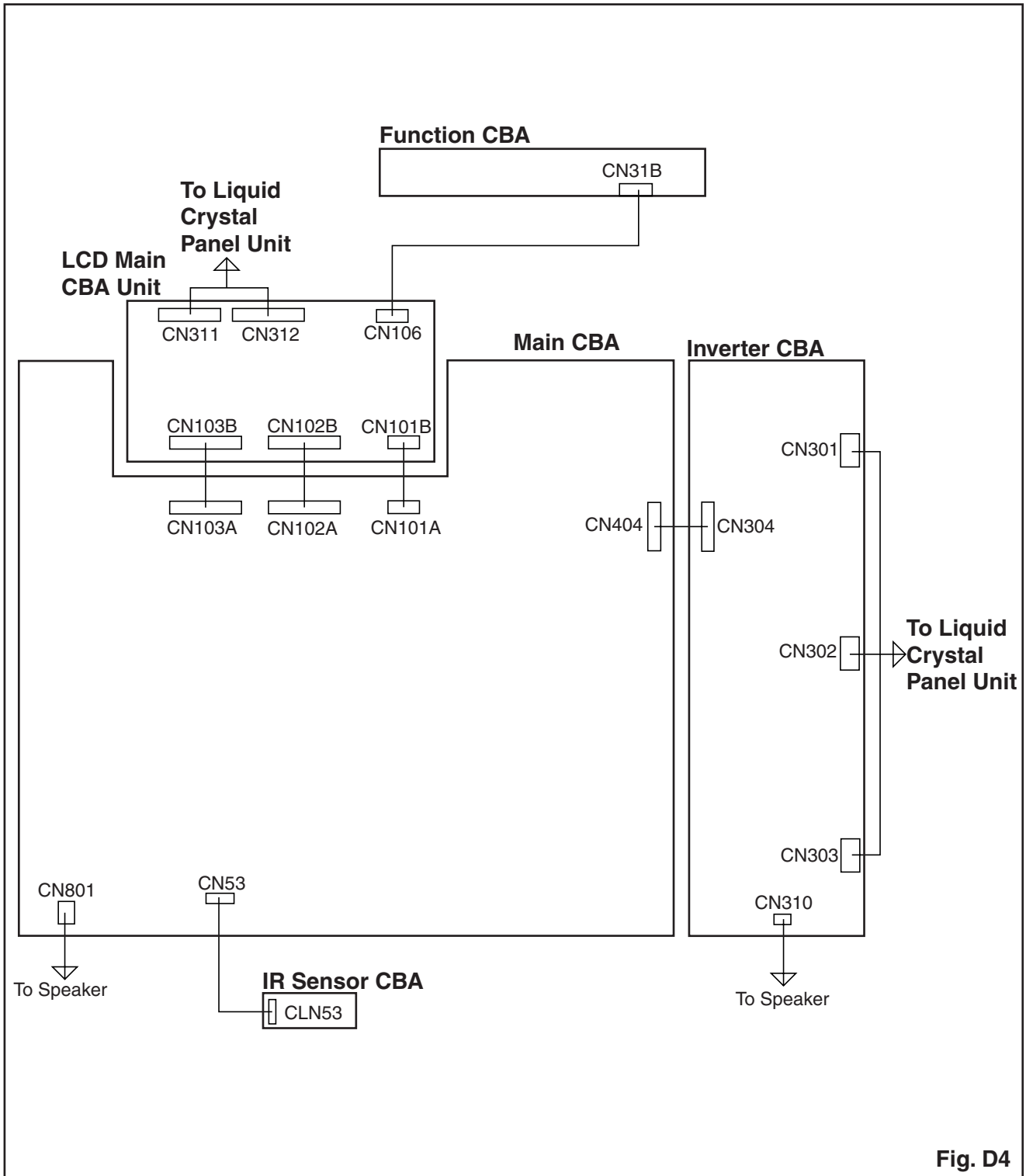
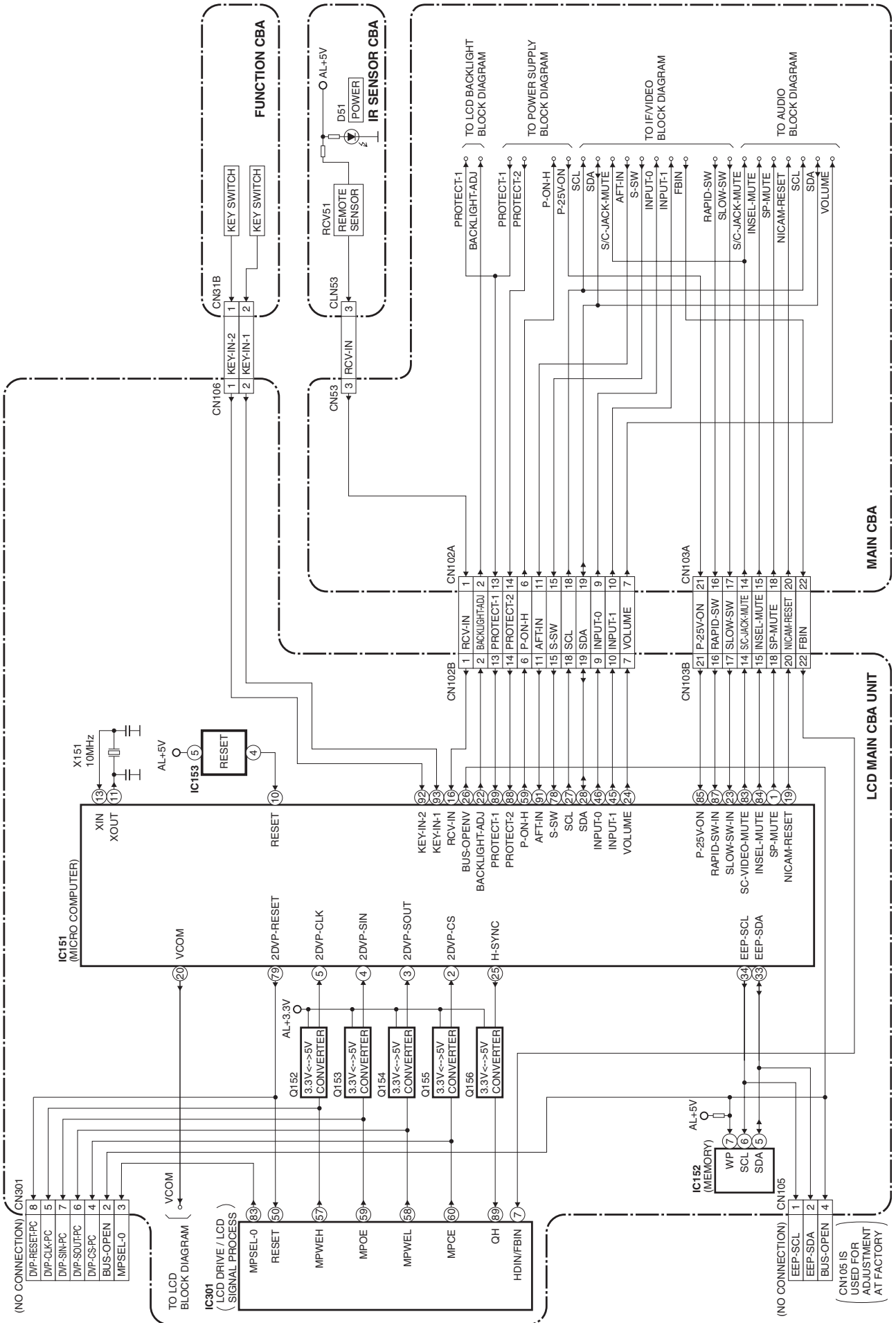

Fig. D4

BLOCK DIAGRAMS

System Control Block Diagram



IF/Video Block Diagram

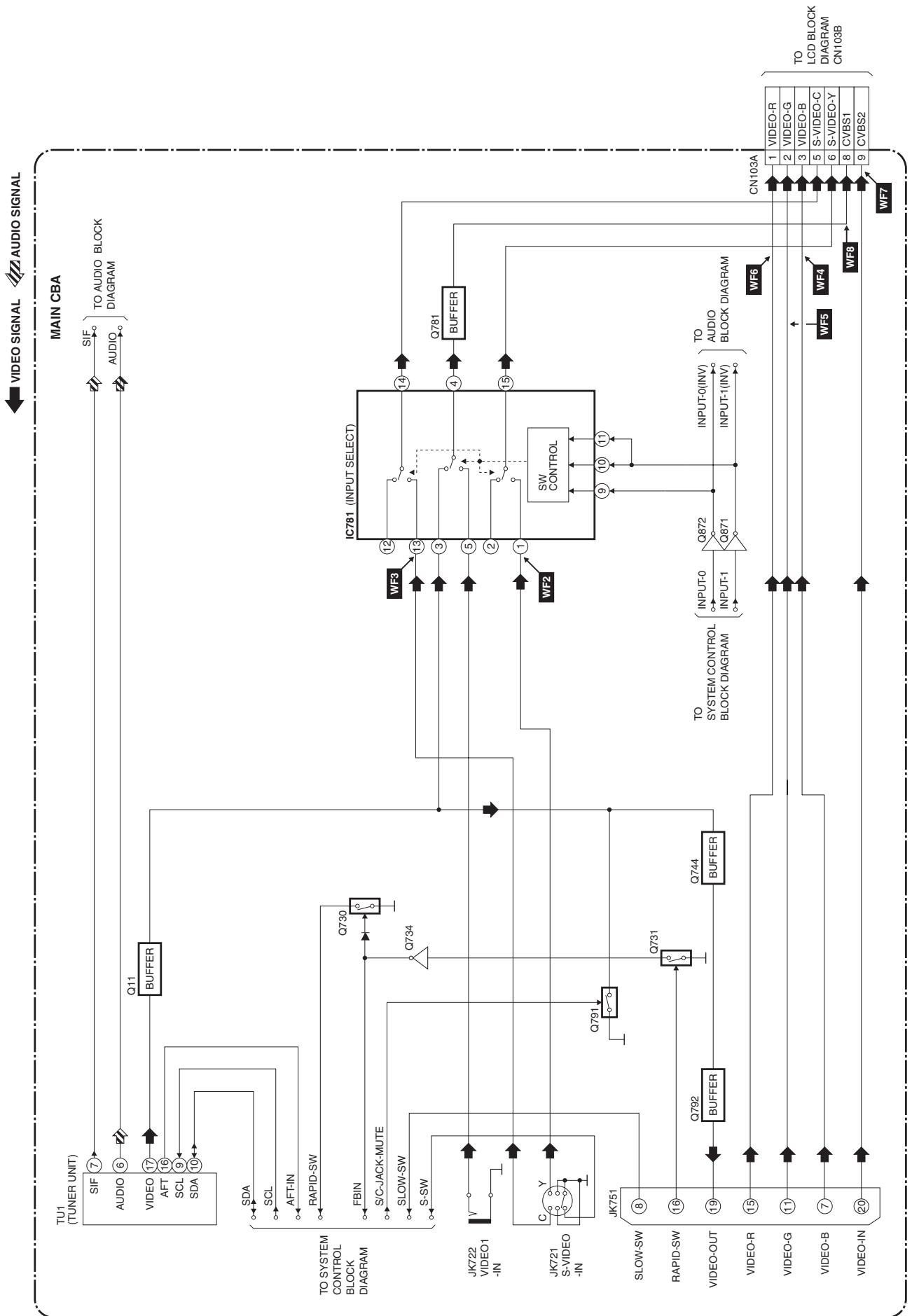

Audio Block Diagram

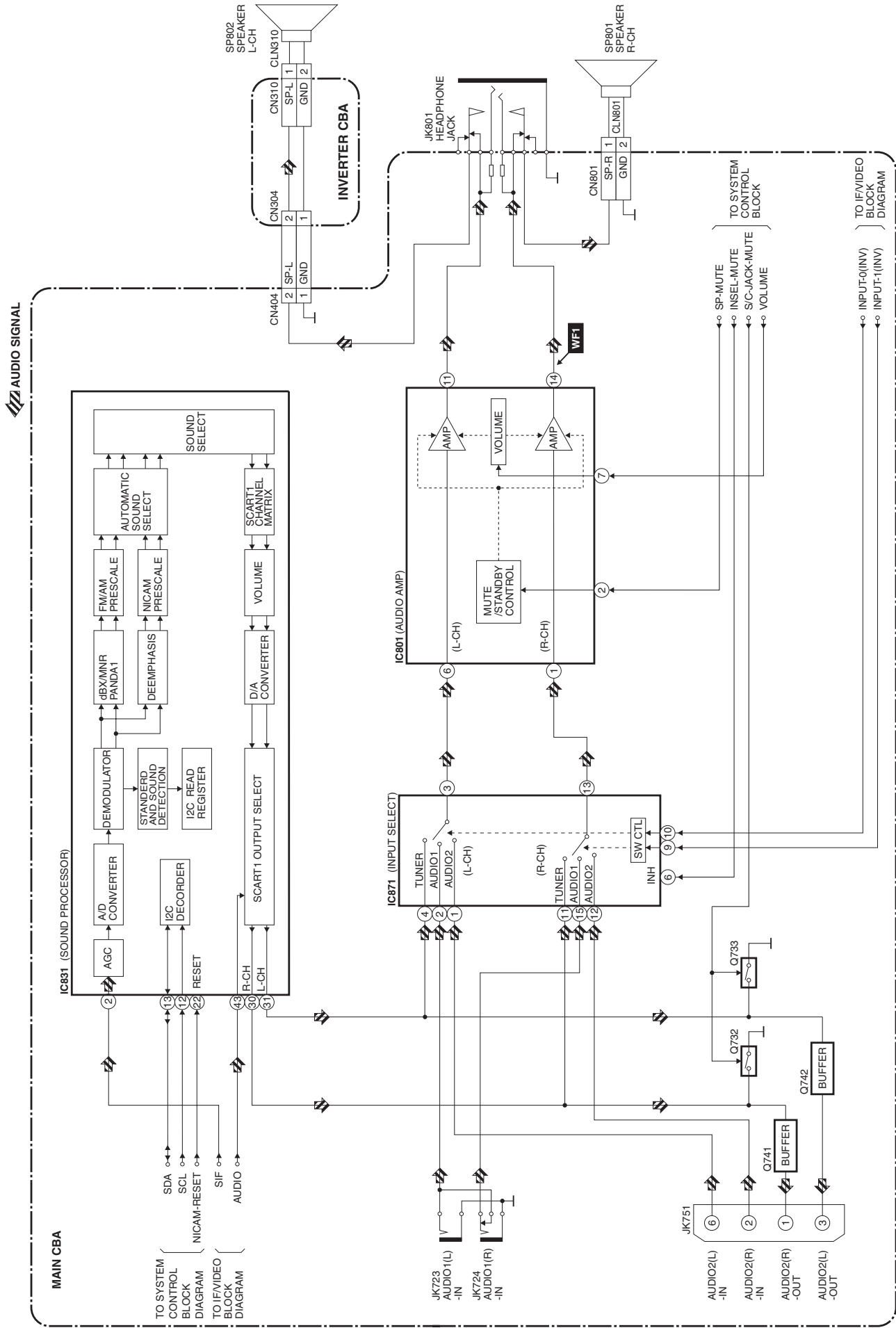

LCD Block Diagram

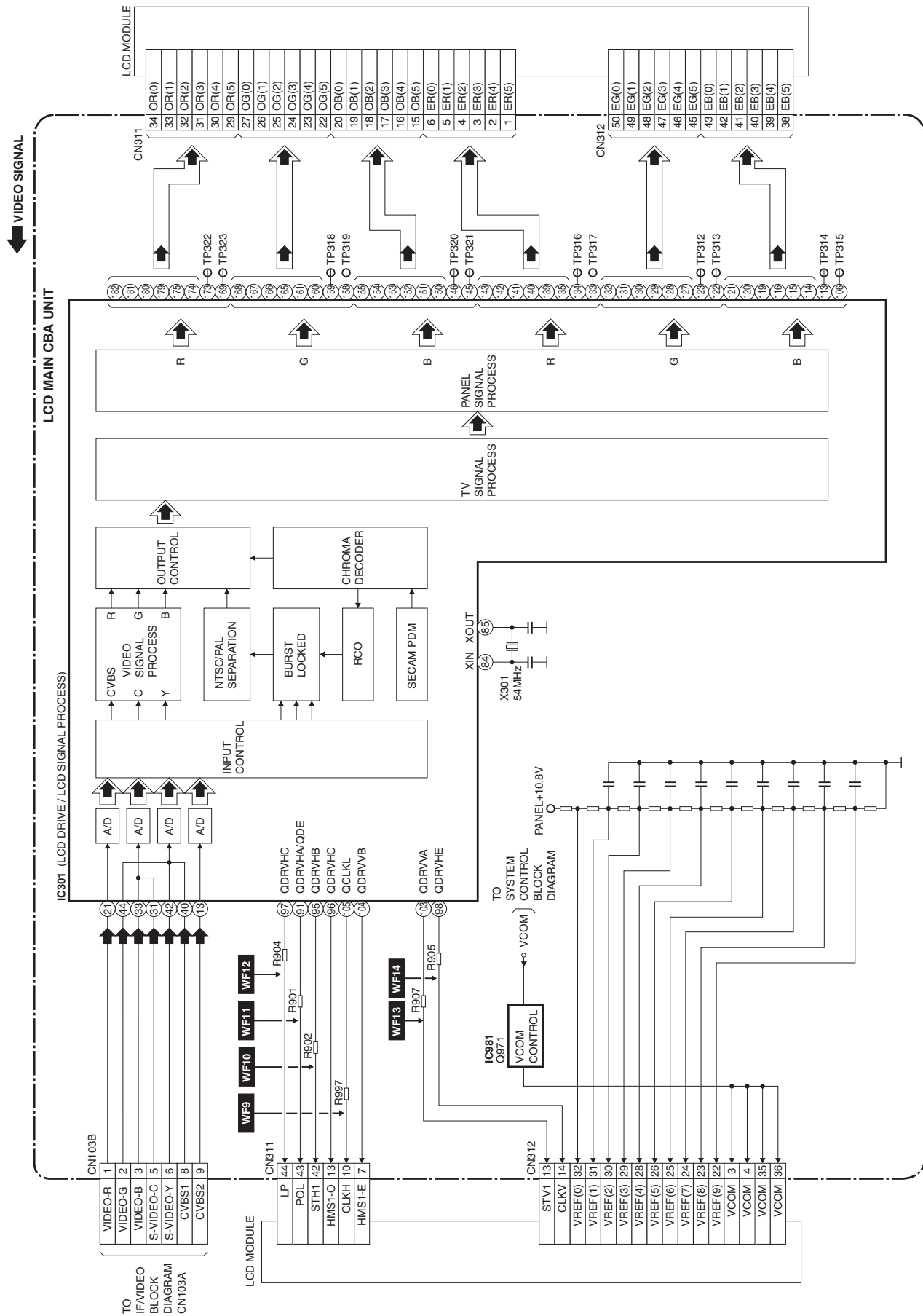

Power Supply Block Diagram

CAUTION !

Fixed voltage (or Auto voltage selectable) power supply circuit is used in this unit. If Main Fuse (F601) is blown, check to see that all components in the power supply circuit are not defective before you connect the AC plug to the AC power supply. Otherwise it may cause some components in the power supply circuit to fail.

CAUTION !

For continued protection against fire hazard, replace only with the same type fuse.

NOTE:

The voltage for parts in hot circuit is measured using hot GND as a common terminal.

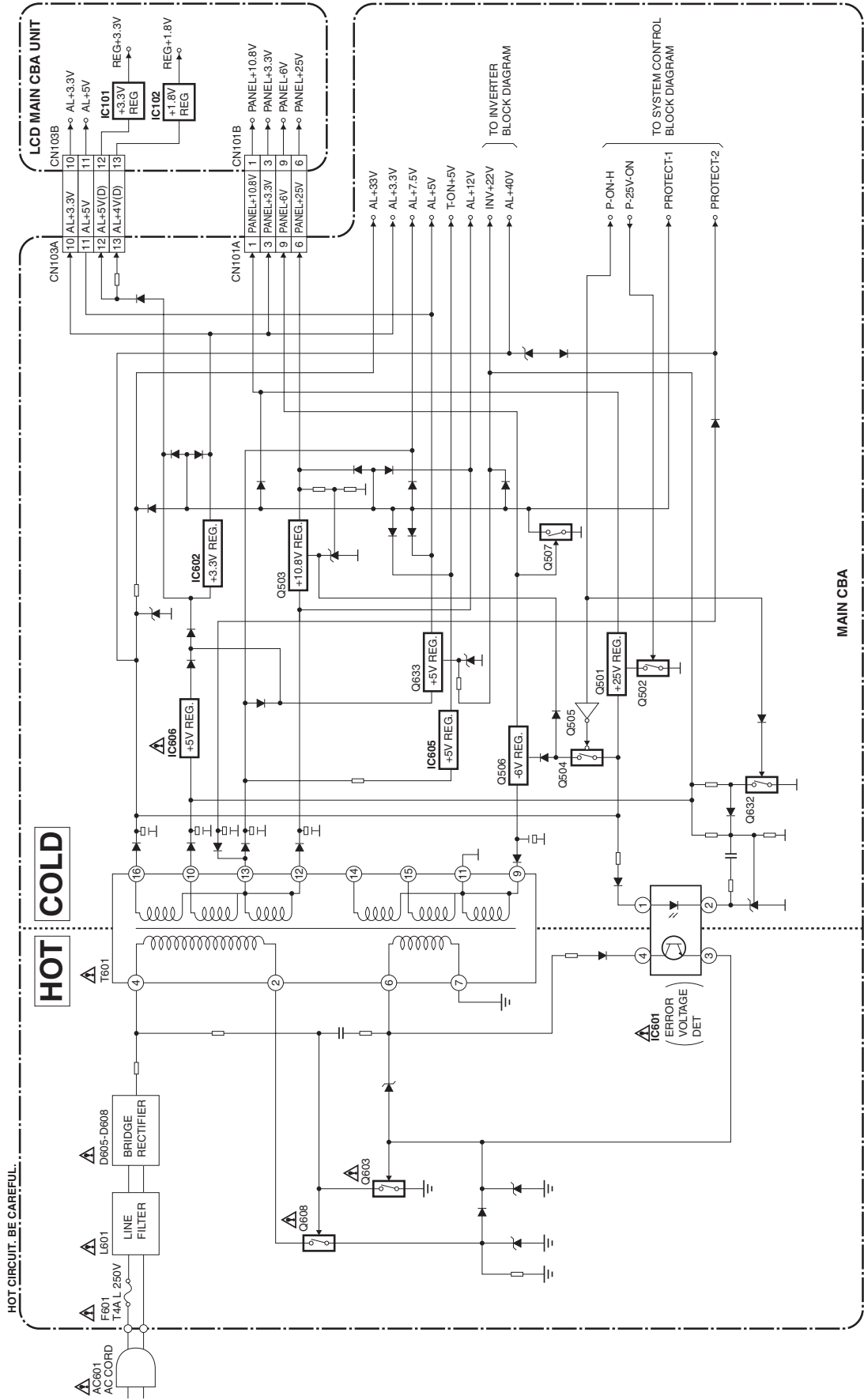

LCD Backlight Block Diagram

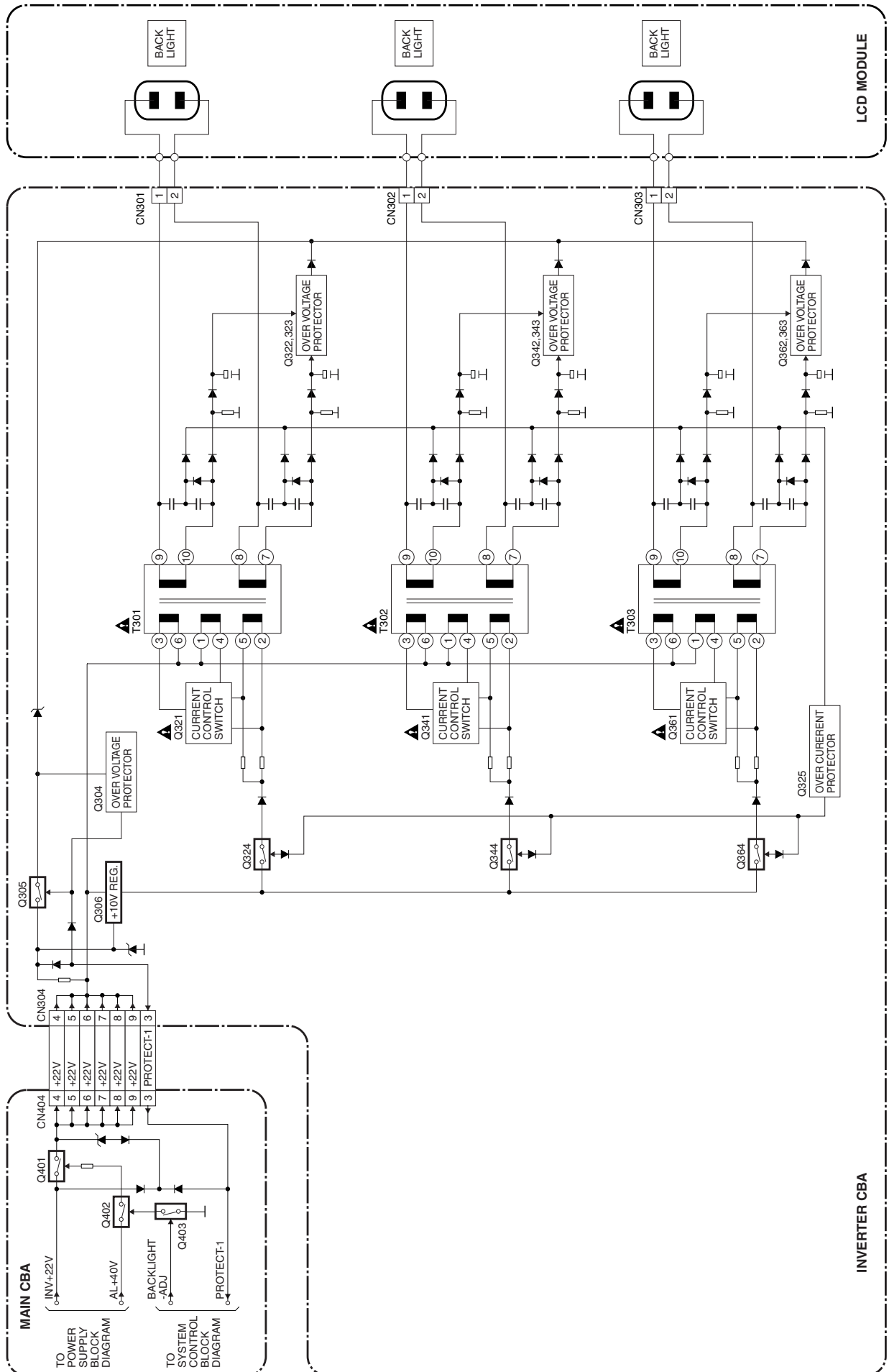

Main 1/4 Schematic Diagram

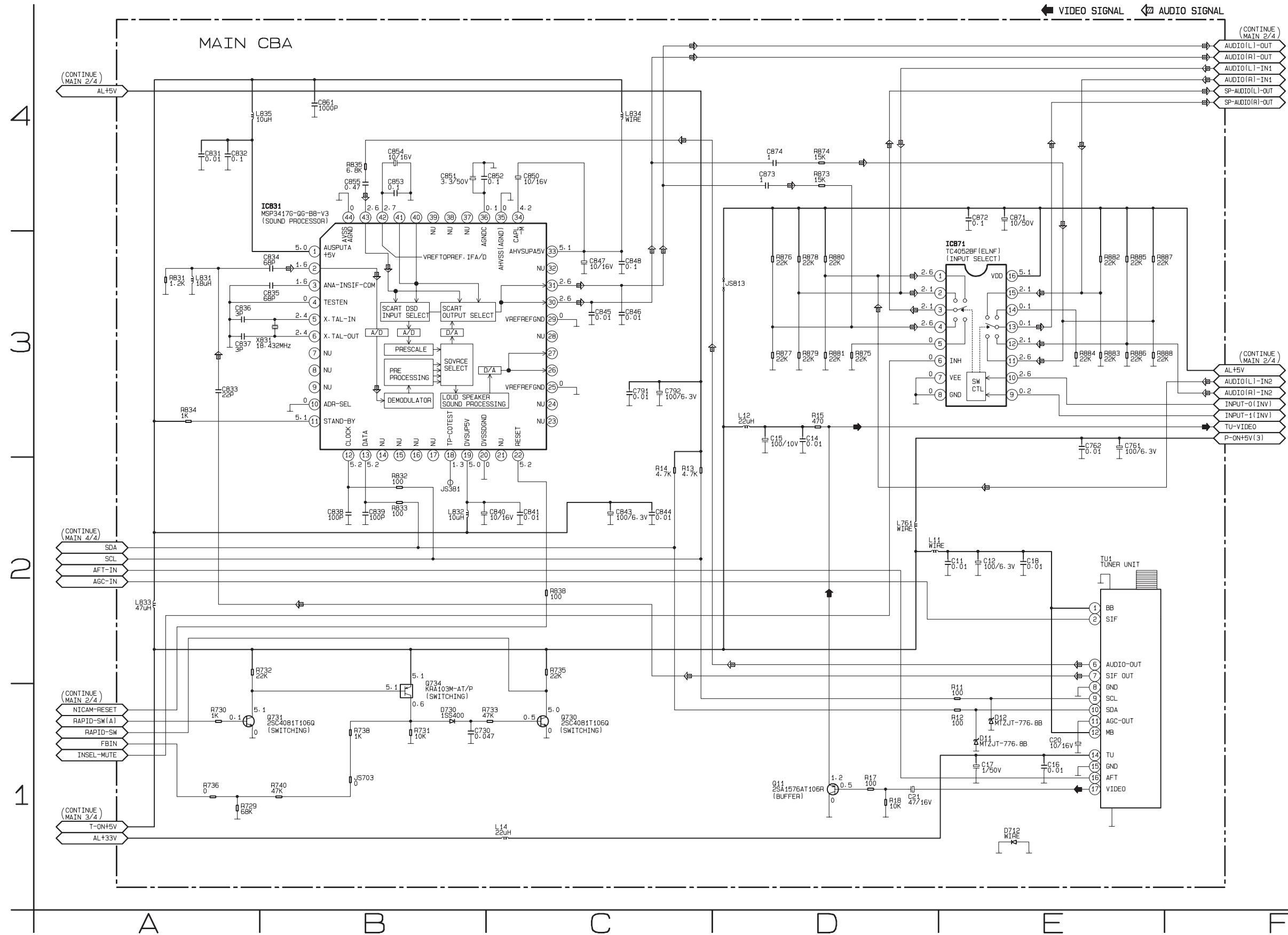

Main 2/4 Schematic Diagram

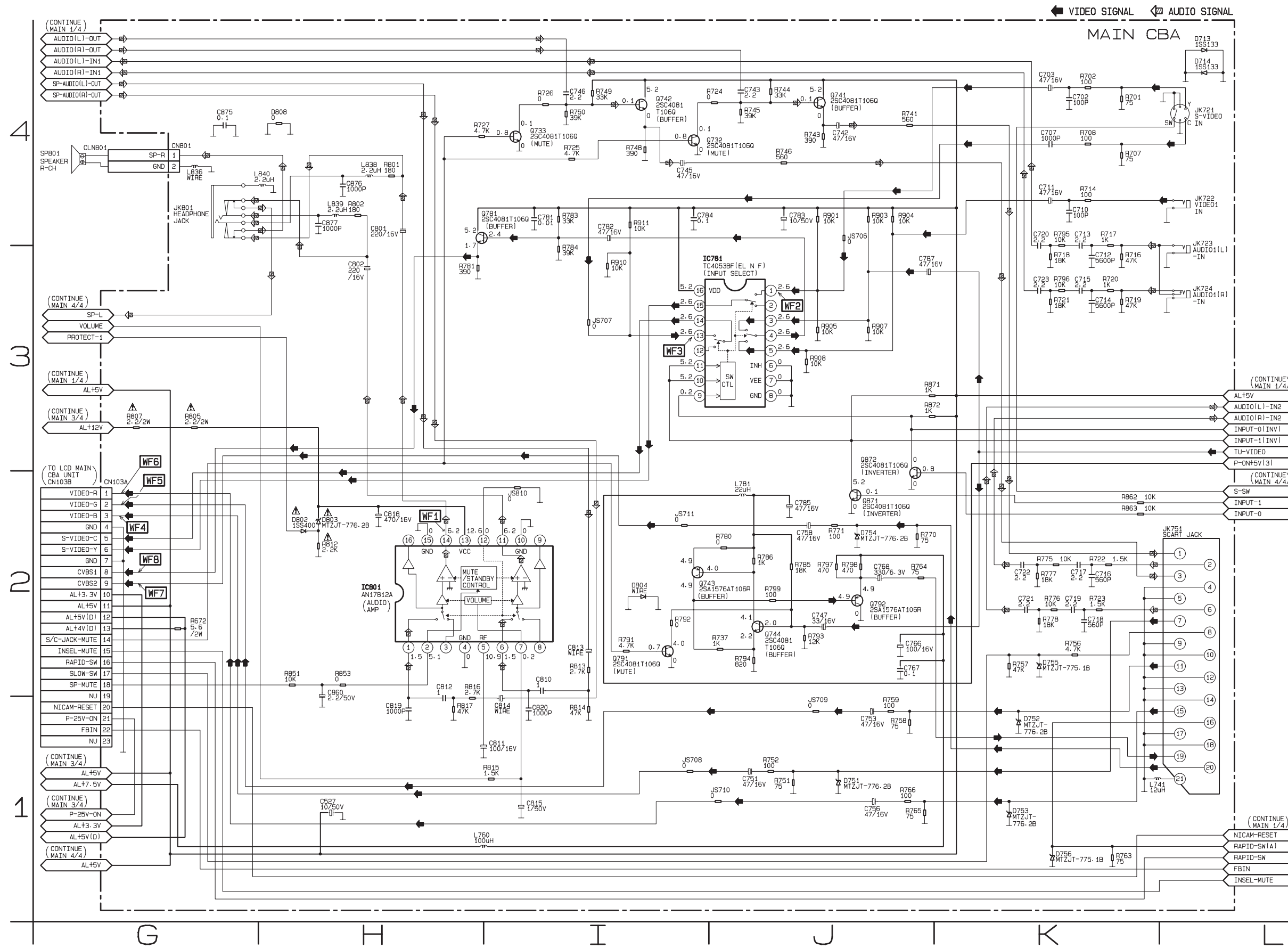

VOLTAGE CHART

CN103A

Pin No.	Voltage
1	0.1
2	0.4
3	0.2
4	0
5	2.6
6	2.6
7	0
8	1.7
9	0.2
10	0
11	3.5
12	5.2
13	6.9
14	3.1
15	0
16	4.8
17	0
18	5.2
19	0
20	5.2
21	3.3
22	3.1
23	0

Main 3/4 Schematic Diagram

CAUTION !

For continued protection against fire hazard, replace only with the same type fuse.

NOTE:

The voltage for parts in hot circuit is measured using hot GND as a common terminal.

CAUTION !

Fixed voltage (or Auto voltage selectable) power supply circuit is used in this unit. If Main Fuse (F601) is blown, check to see that all components in the power supply circuit are not defective before you connect the AC plug to the AC power supply. Otherwise it may cause some components in the power supply circuit to fail.

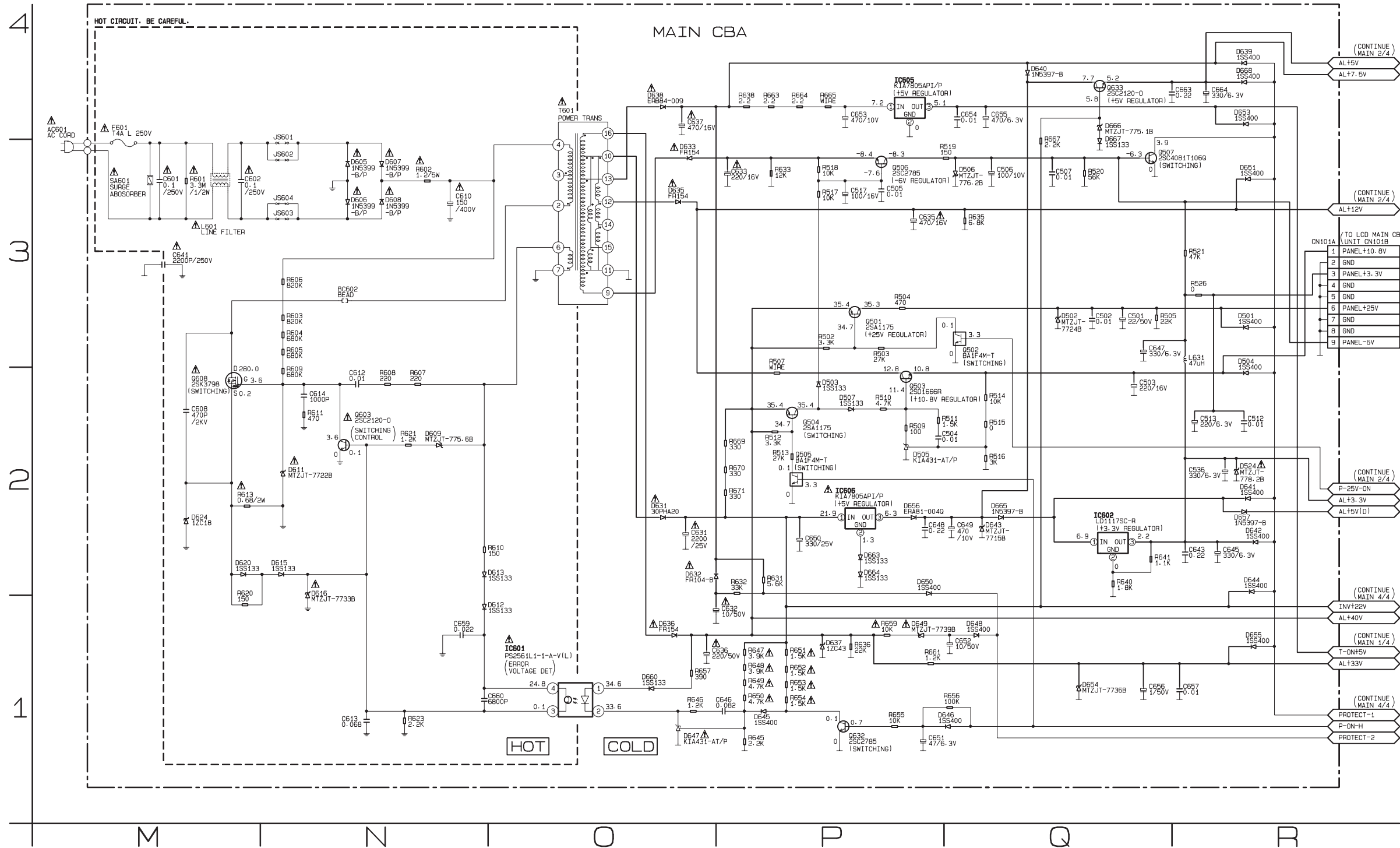

VOLTAGE CHART
CN101A

Pin No.	Voltage
1	10.8
2	0
3	3.4
4	0
5	0
6	25.9
7	0
8	0
9	-6.3

Main 4/4 & IR Sensor Schematic Diagram

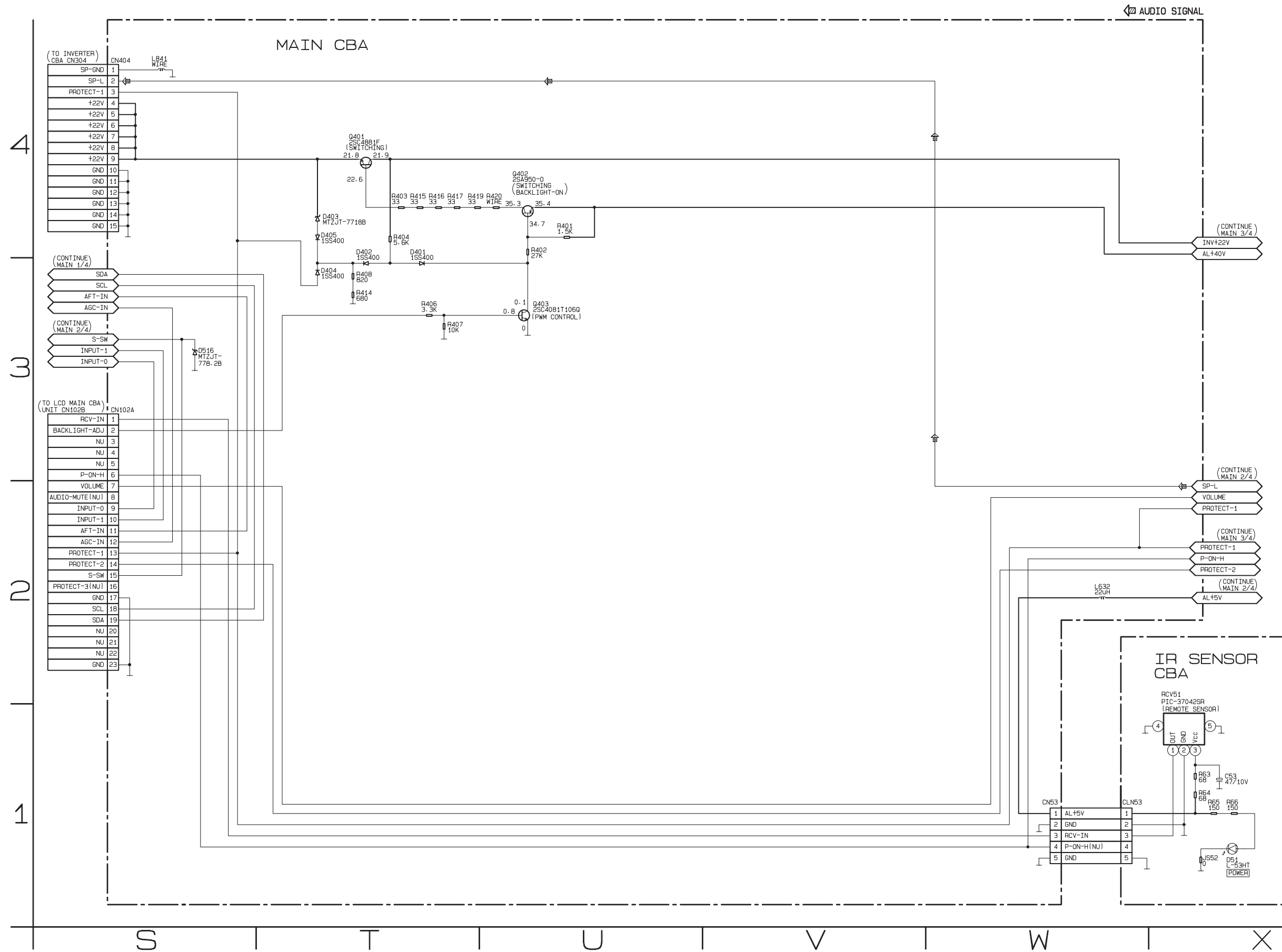

VOLTAGE CHART
CN102A

Pin No.	Voltage
1	3.8
2	0
3	0.1
4	5.2
5	5.2
6	3.3
7	0.2
8	0
9	2.0
10	0
11	4.4
12	0.4
13	3.8
14	1.5
15	3.4
16	0
17	0
18	5.2
19	5.2
20	0
21	0
22	0
23	0

Function Schematic Diagram

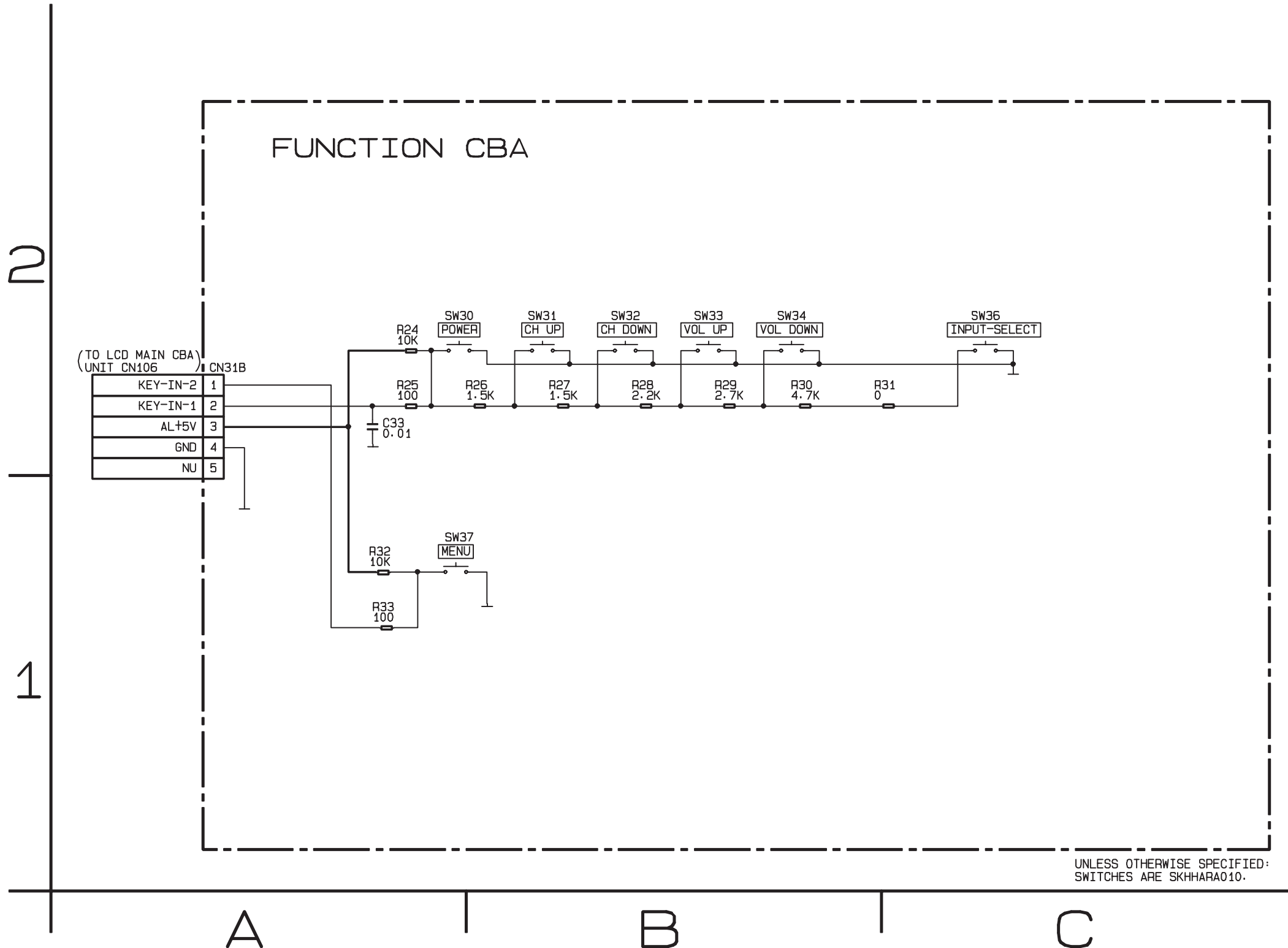

Inverter Schematic Diagram

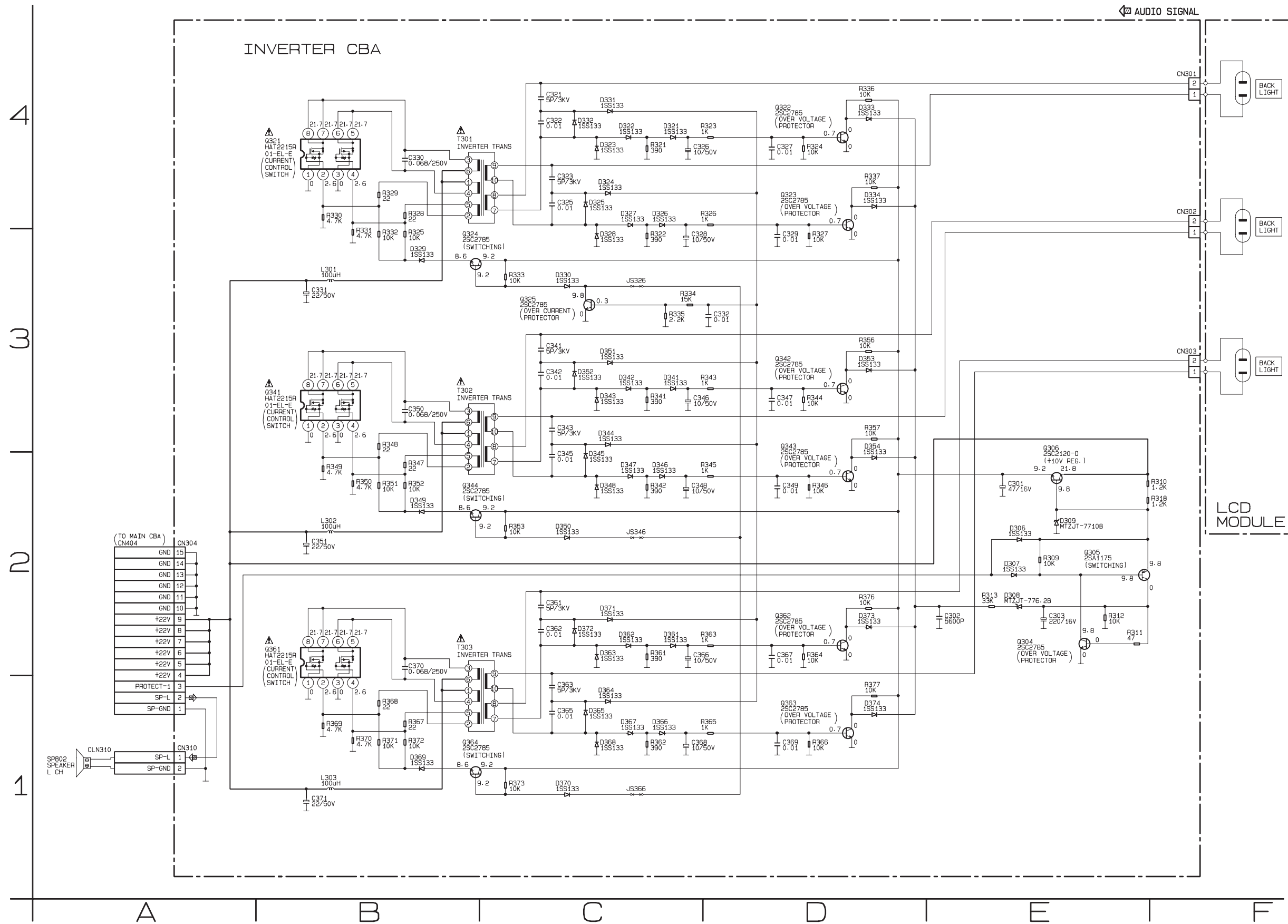

LCD Main 1/2 Schematic Diagram

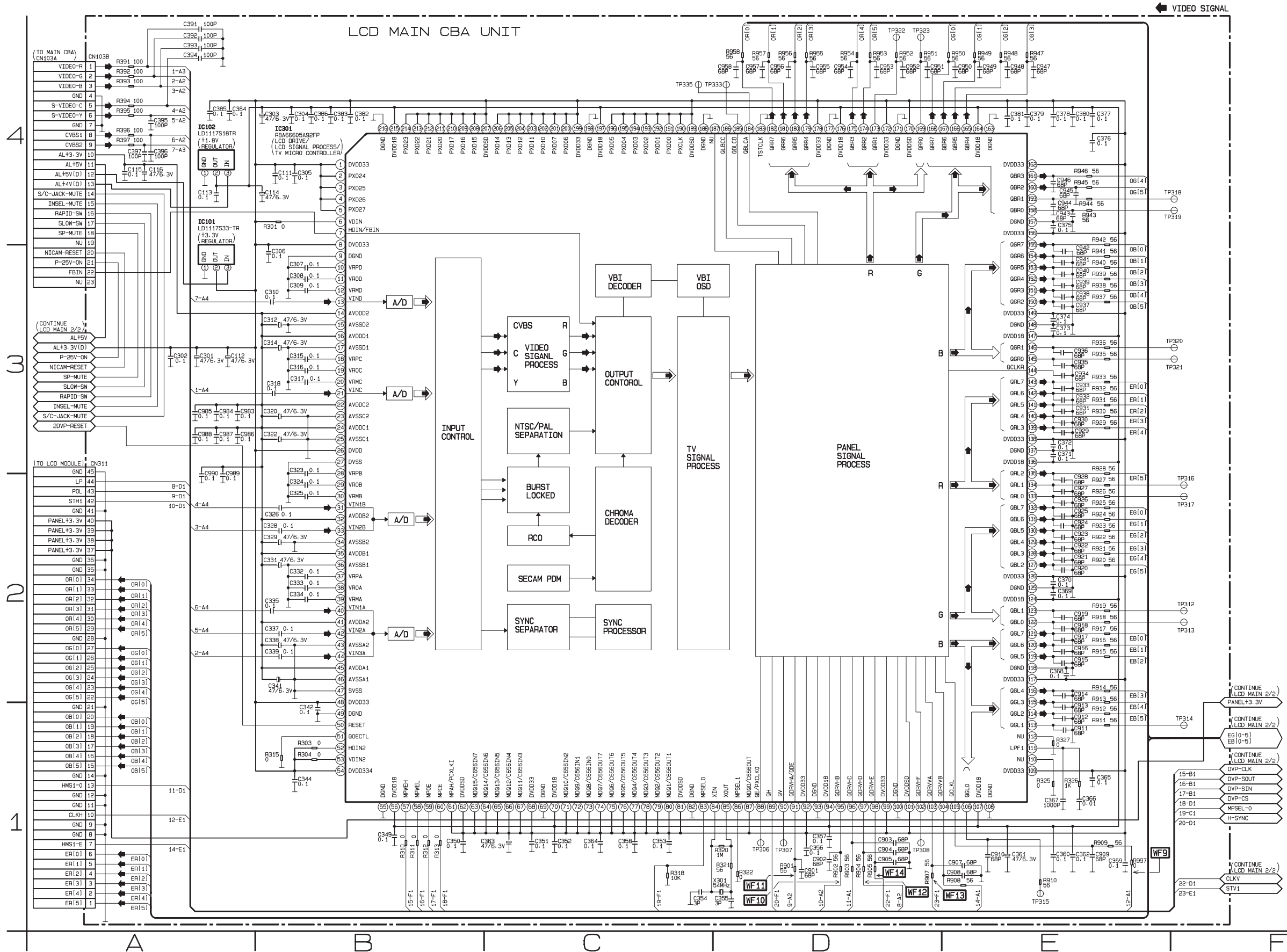

LCD Main 2/2 Schematic Diagram

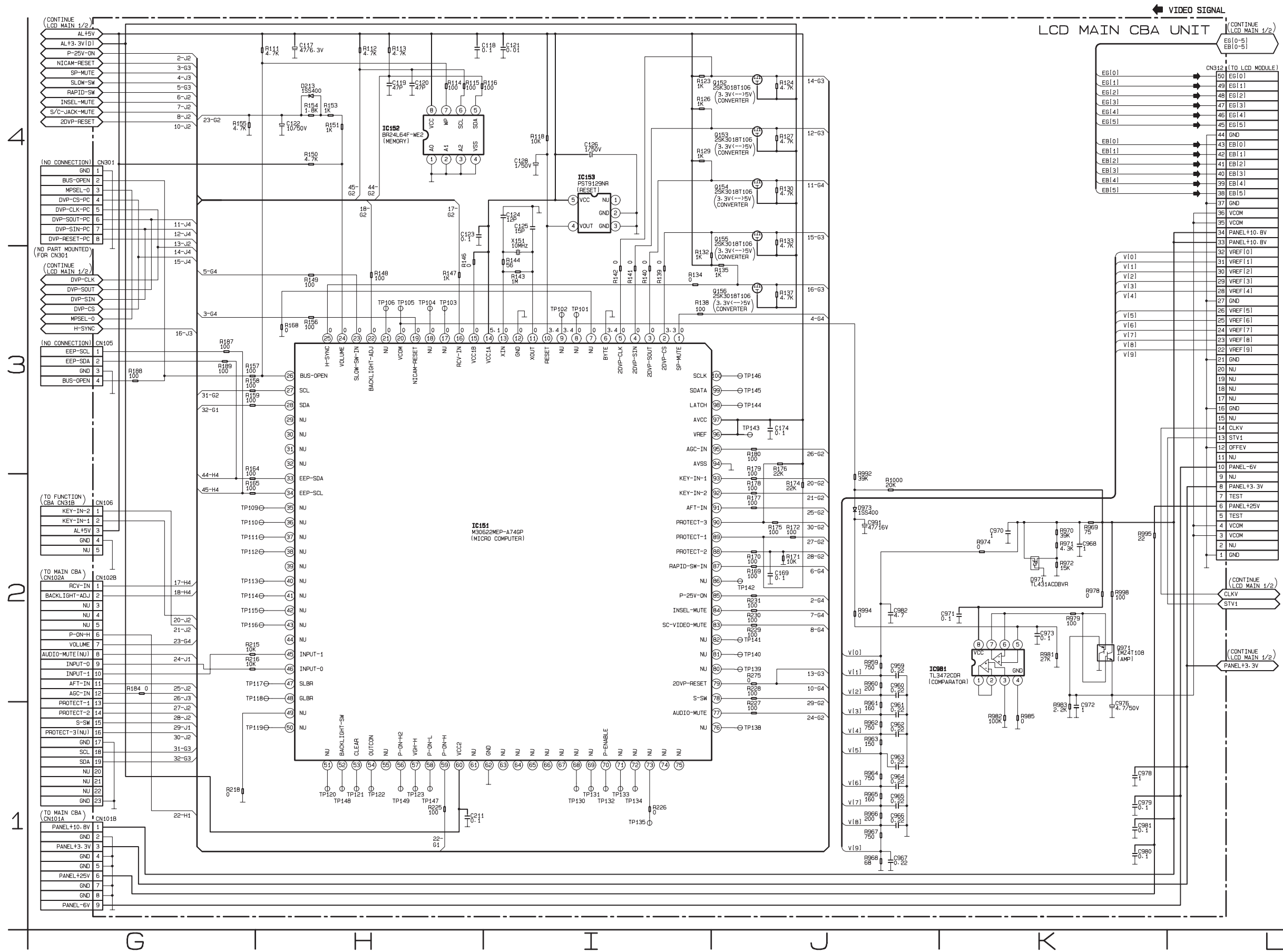

Main CBA Top View

CAUTION !
For continued protection against fire hazard, replace only with the same type fuse.

NOTE:
The voltage for parts in hot circuit is measured using hot GND as a common terminal.

CAUTION !
Fixed voltage (or Auto voltage selectable) power supply circuit is used in this unit.
If Main Fuse (F601) is blown, check to see that all components in the power supply circuit are not defective before you connect the AC plug to the AC power supply.
Otherwise it may cause some components in the power supply circuit to fail.

Because a hot chassis ground is present in the power supply circuit, an isolation transformer must be used. Also, in order to have the ability to increase the input slowly, when troubleshooting this type power supply circuit, a variable isolation transformer is required.

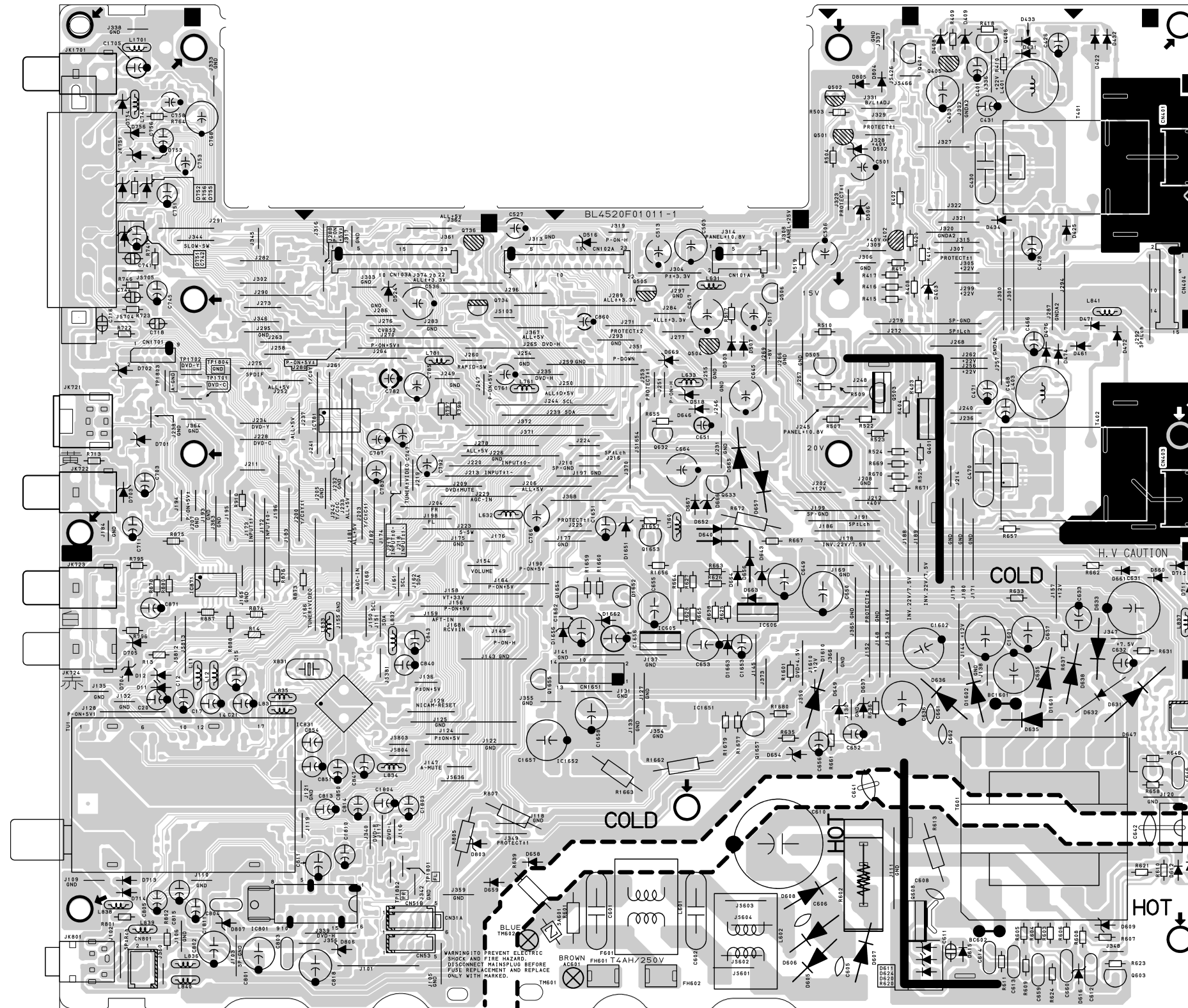

Main CBA Bottom View

CAUTION !
For continued protection against fire hazard, replace only with the same type fuse.

NOTE:
The voltage for parts in hot circuit is measured using hot GND as a common terminal.

CAUTION !
Fixed voltage (or Auto voltage selectable) power supply circuit is used in this unit.
If Main Fuse (F601) is blown, check to see that all components in the power supply circuit are not defective before you connect the AC plug to the AC power supply.
Otherwise it may cause some components in the power supply circuit to fail.

Because a hot chassis ground is present in the power supply circuit, an isolation transformer must be used.
Also, in order to have the ability to increase the input slowly, when troubleshooting this type power supply circuit, a variable isolation transformer is required.

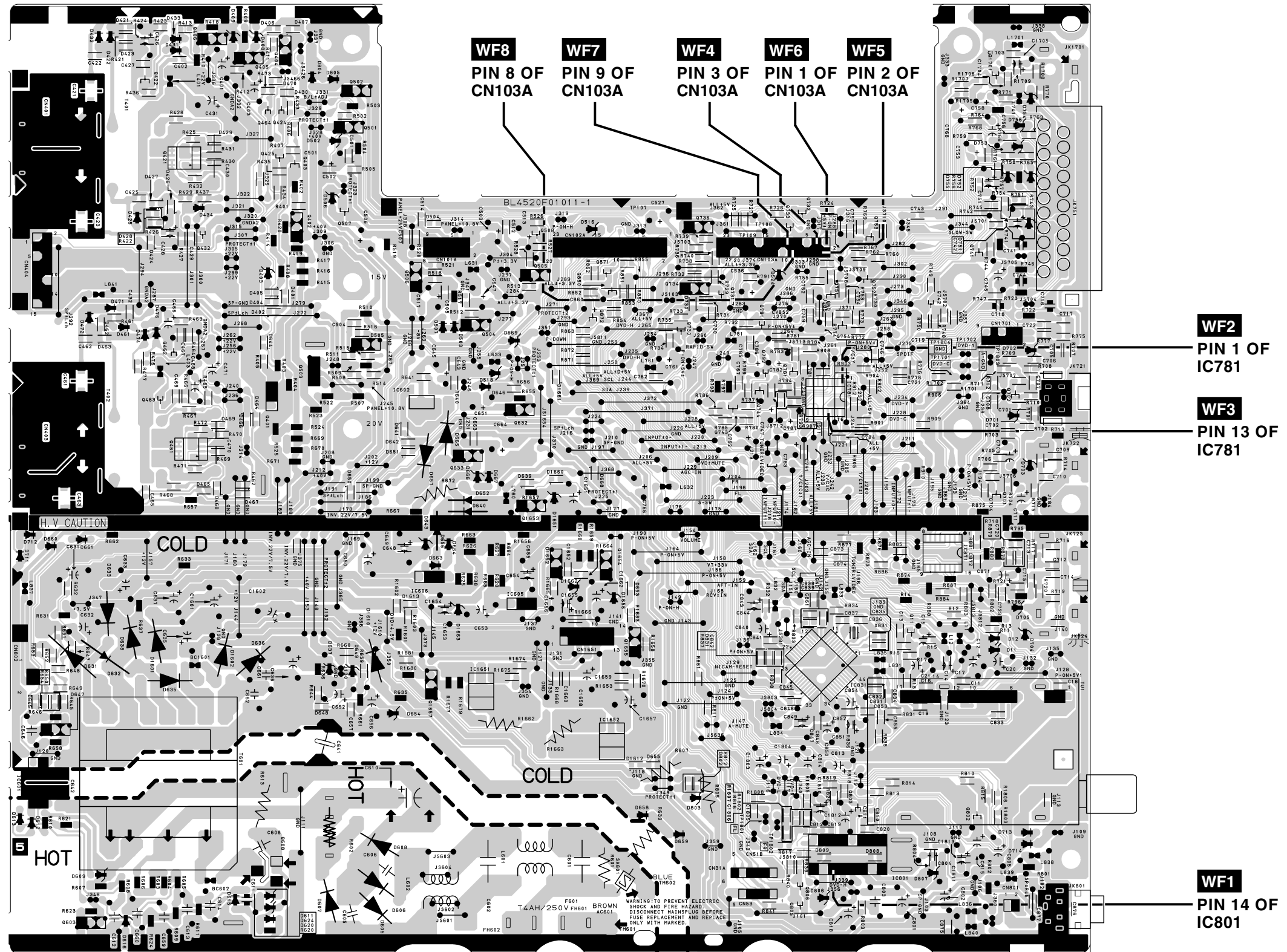

Function CBA Top View

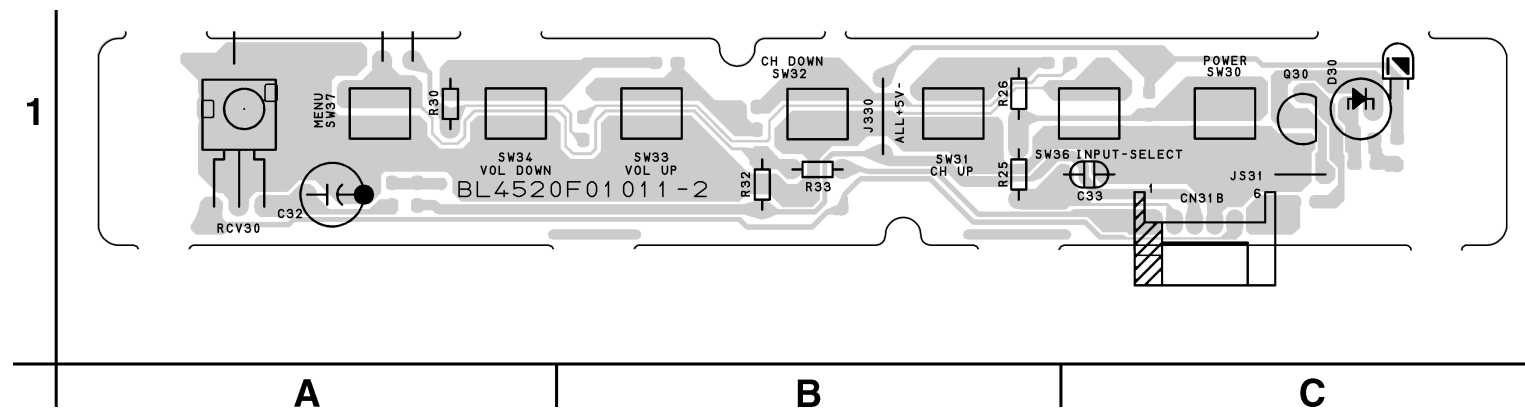

IR Sensor CBA Top & Bottom View

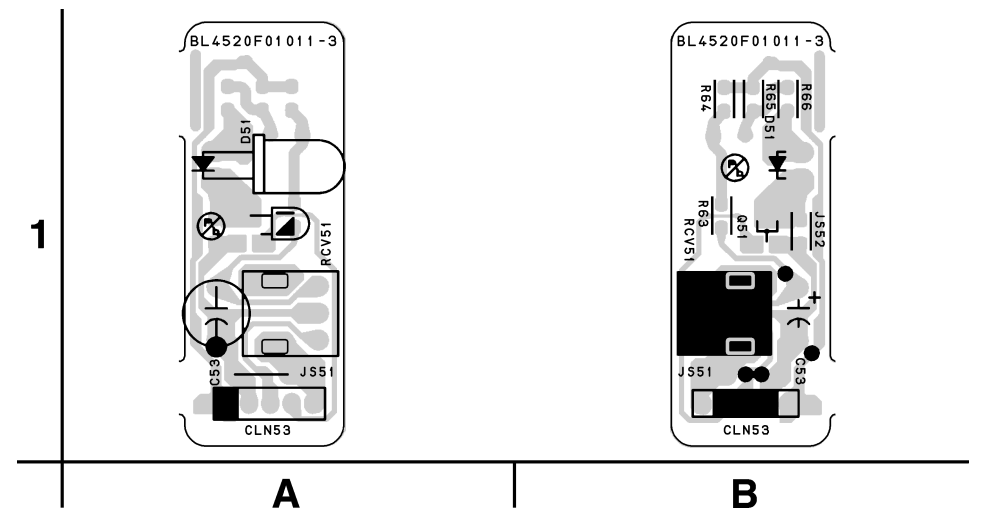

BL4520F01011-3

Function CBA Bottom View

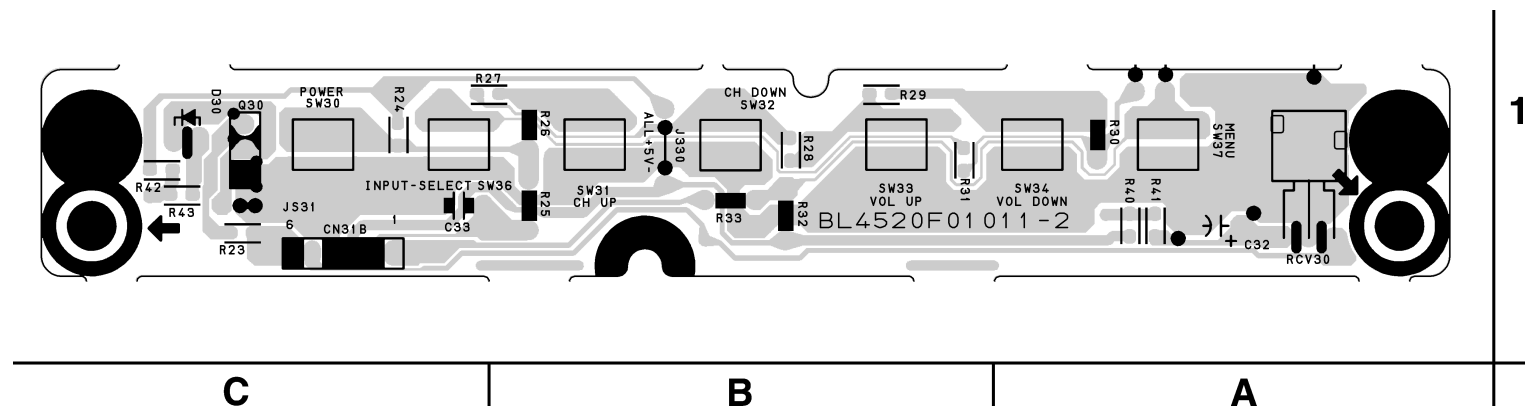

BL4520F01011-2

Inverter CBA Top View

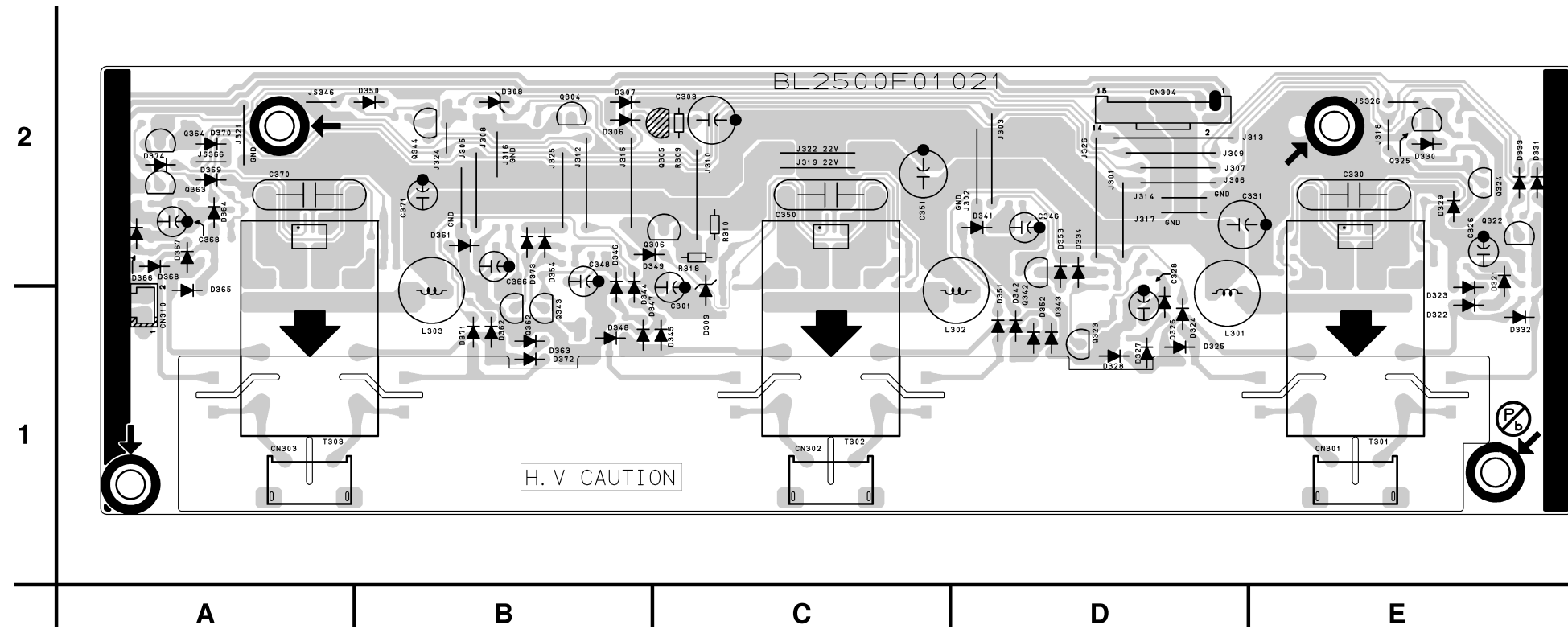

Inverter CBA Bottom View

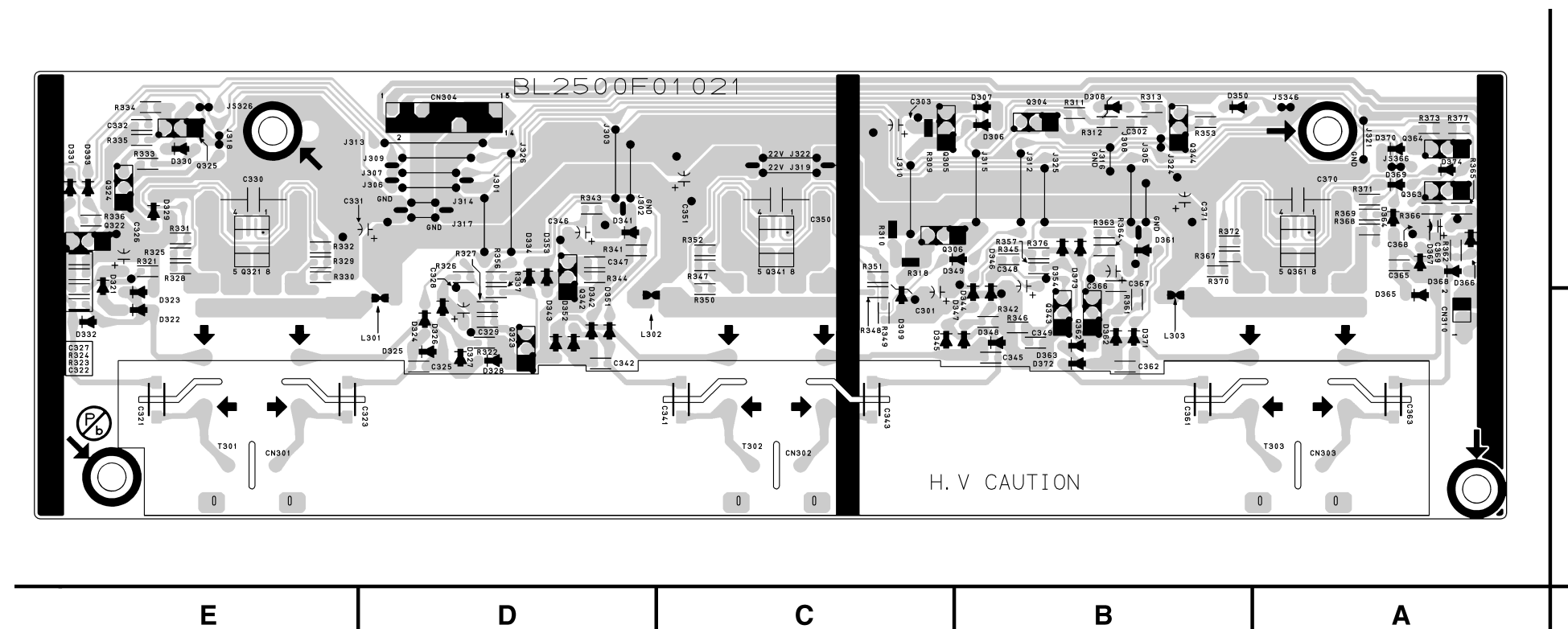

WIRING DIAGRAMS

