

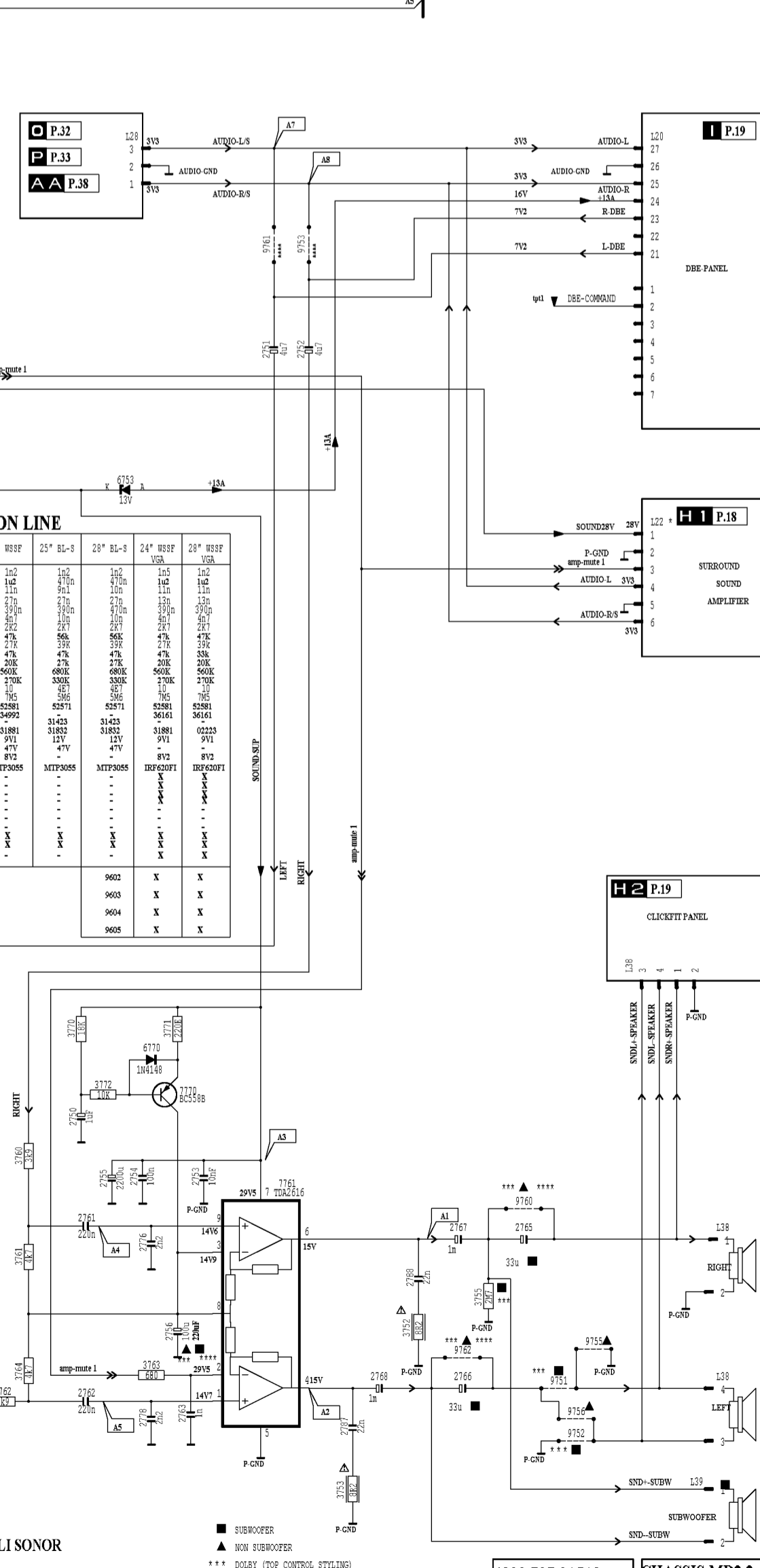

# LARGE SIGNAL PANEL

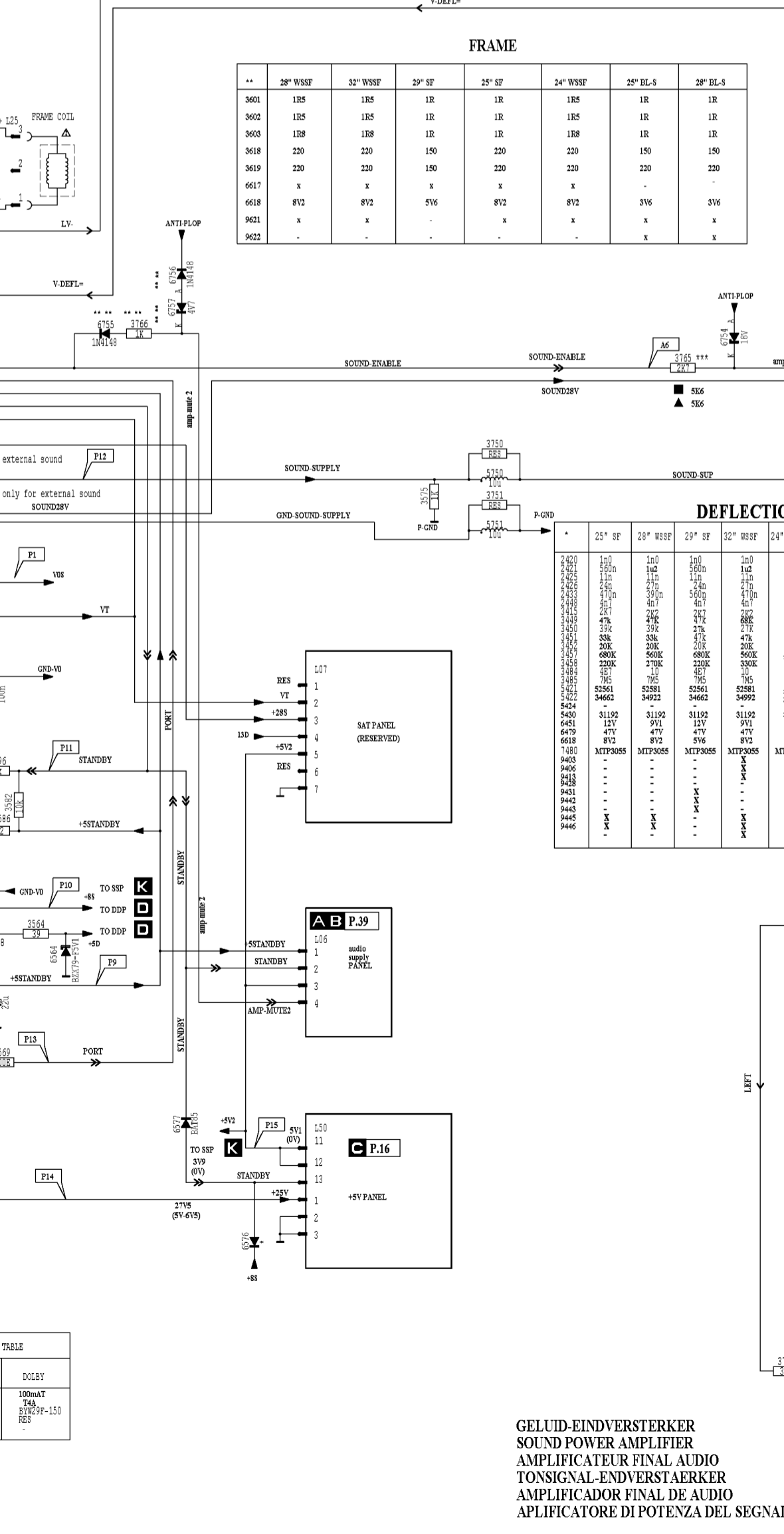
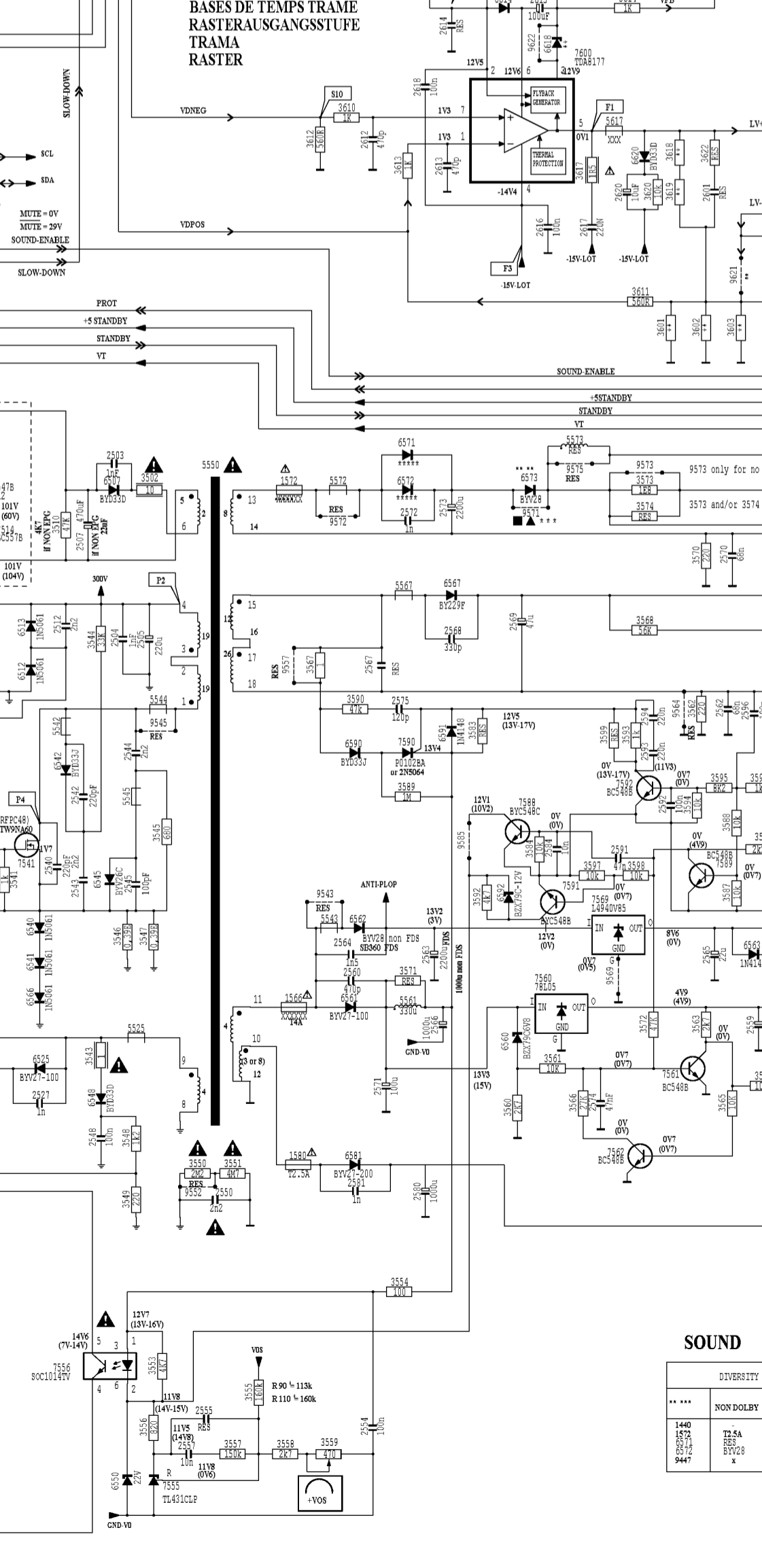
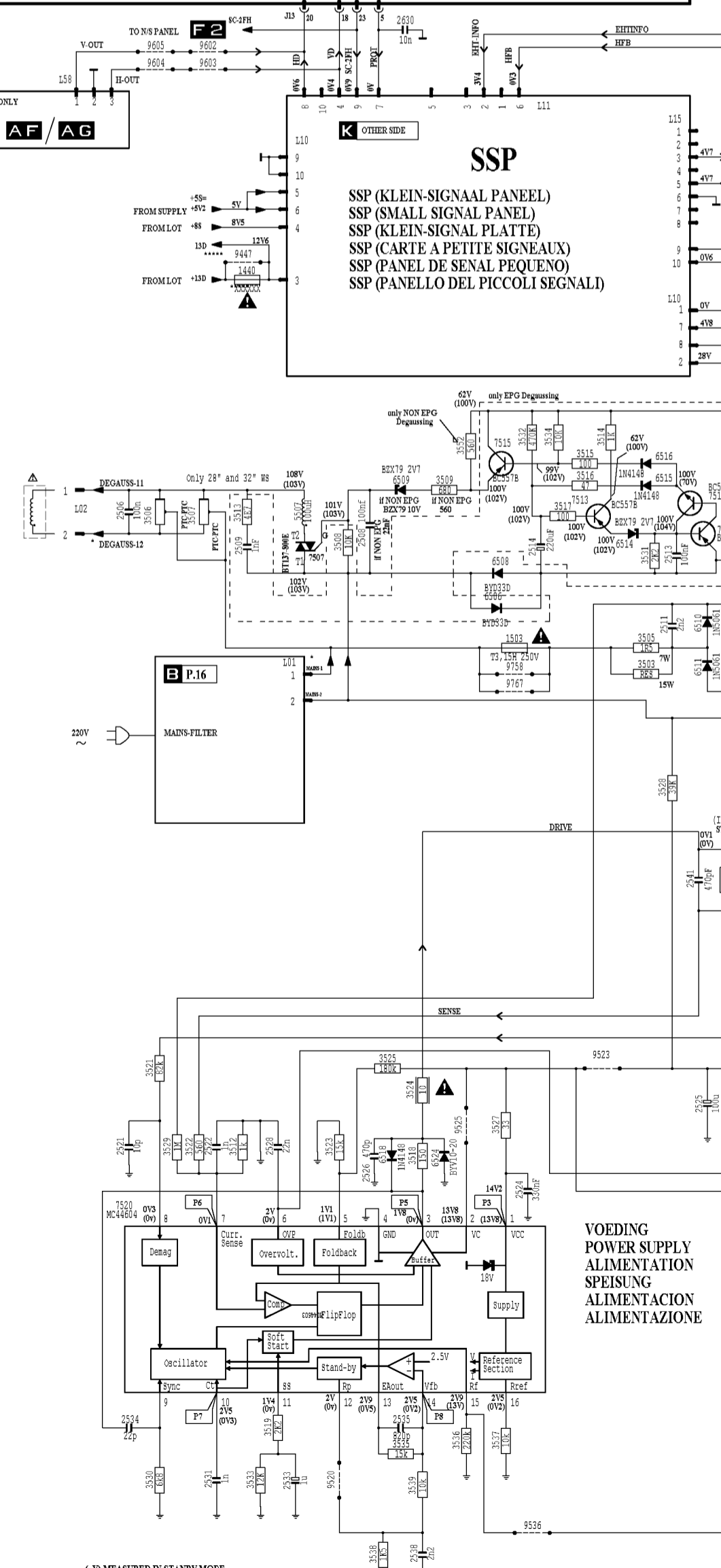
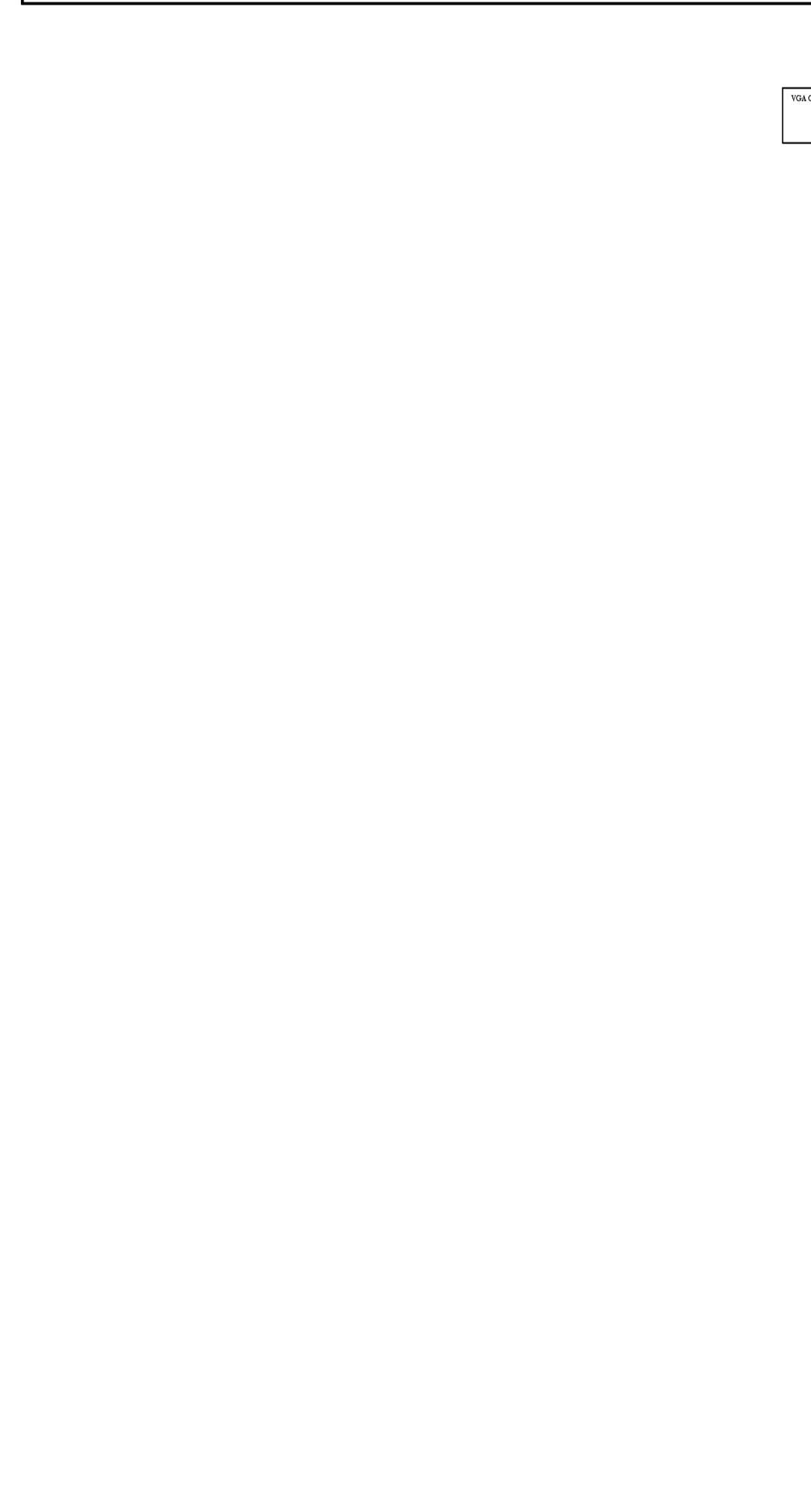
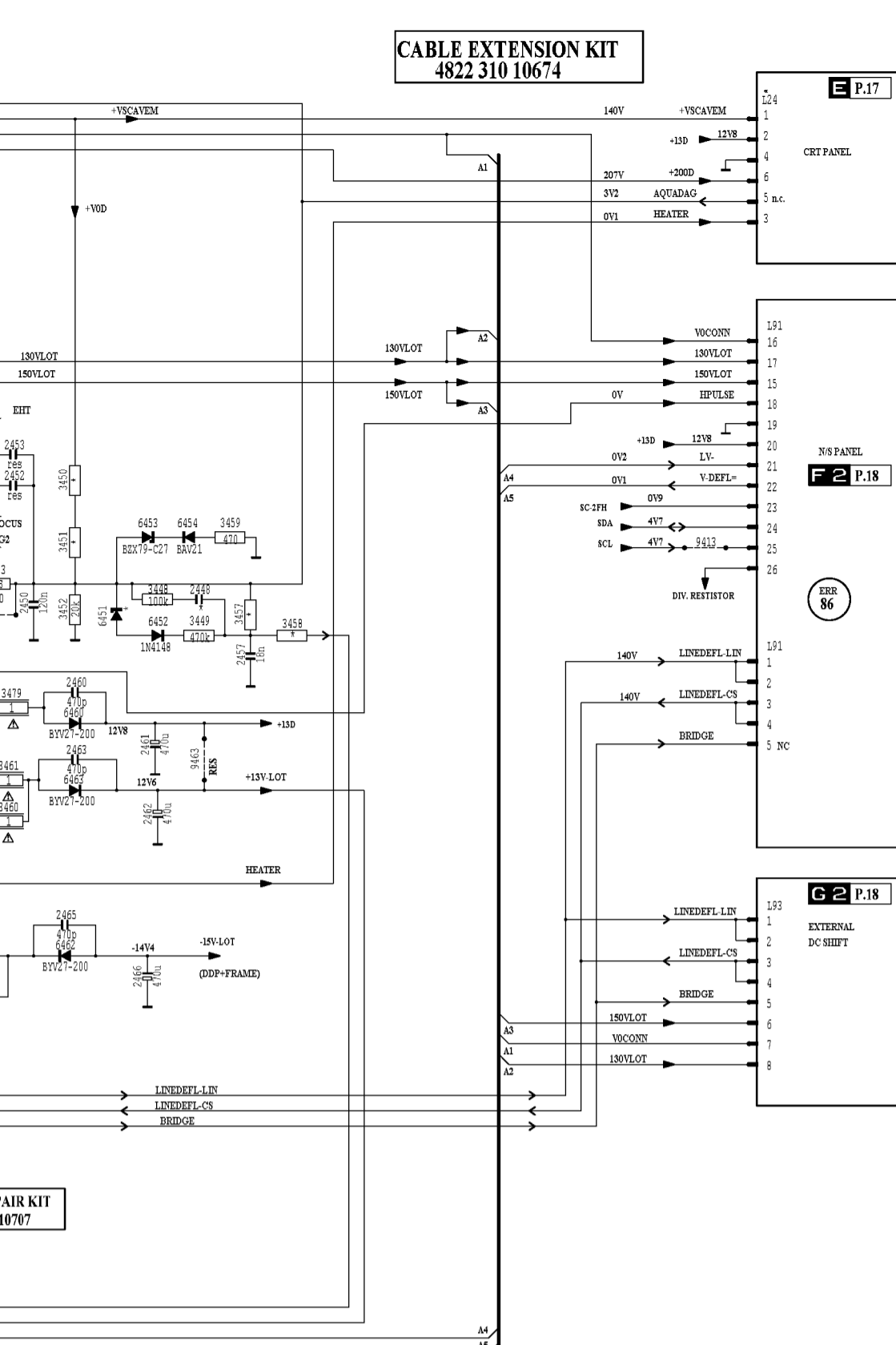
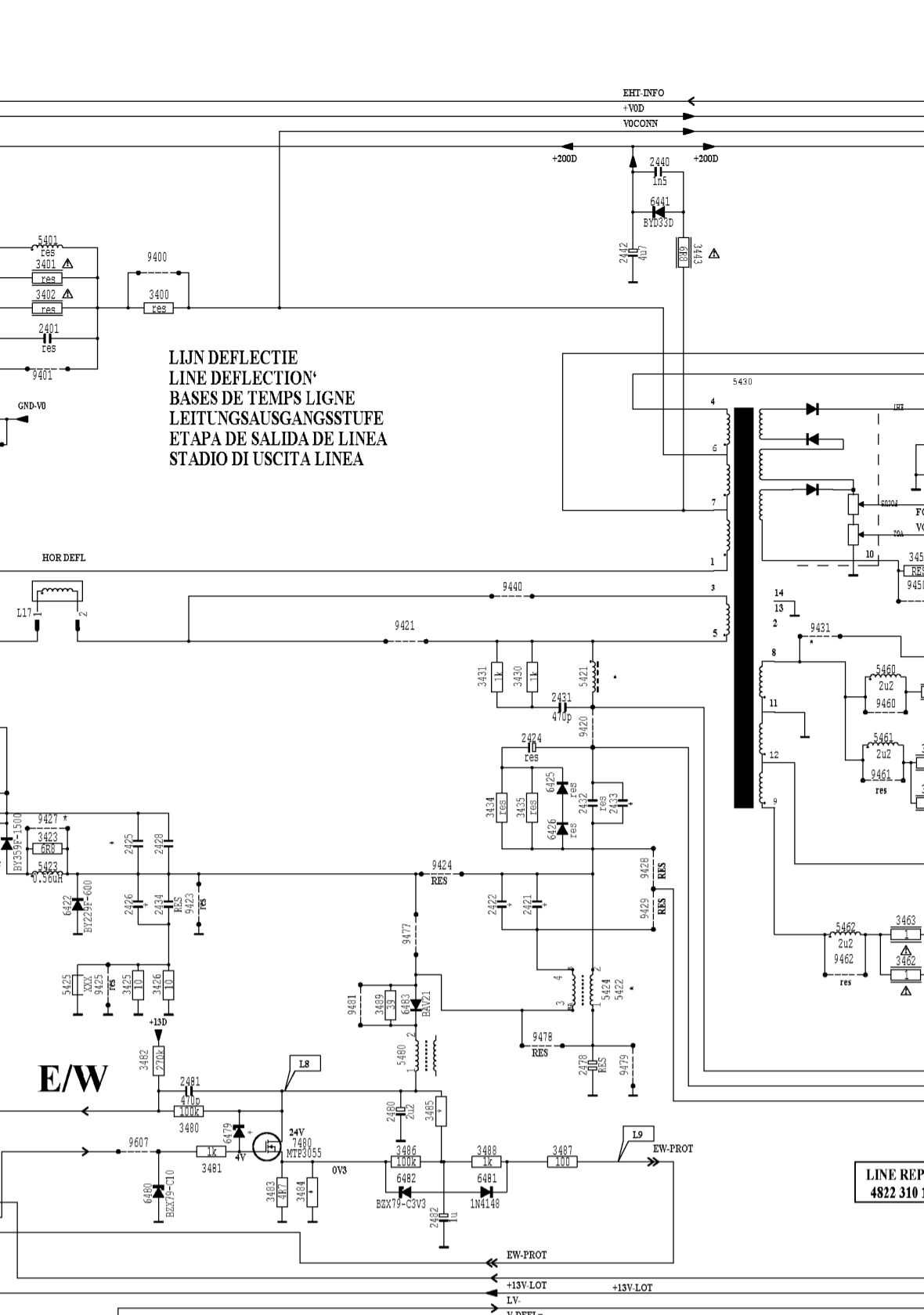
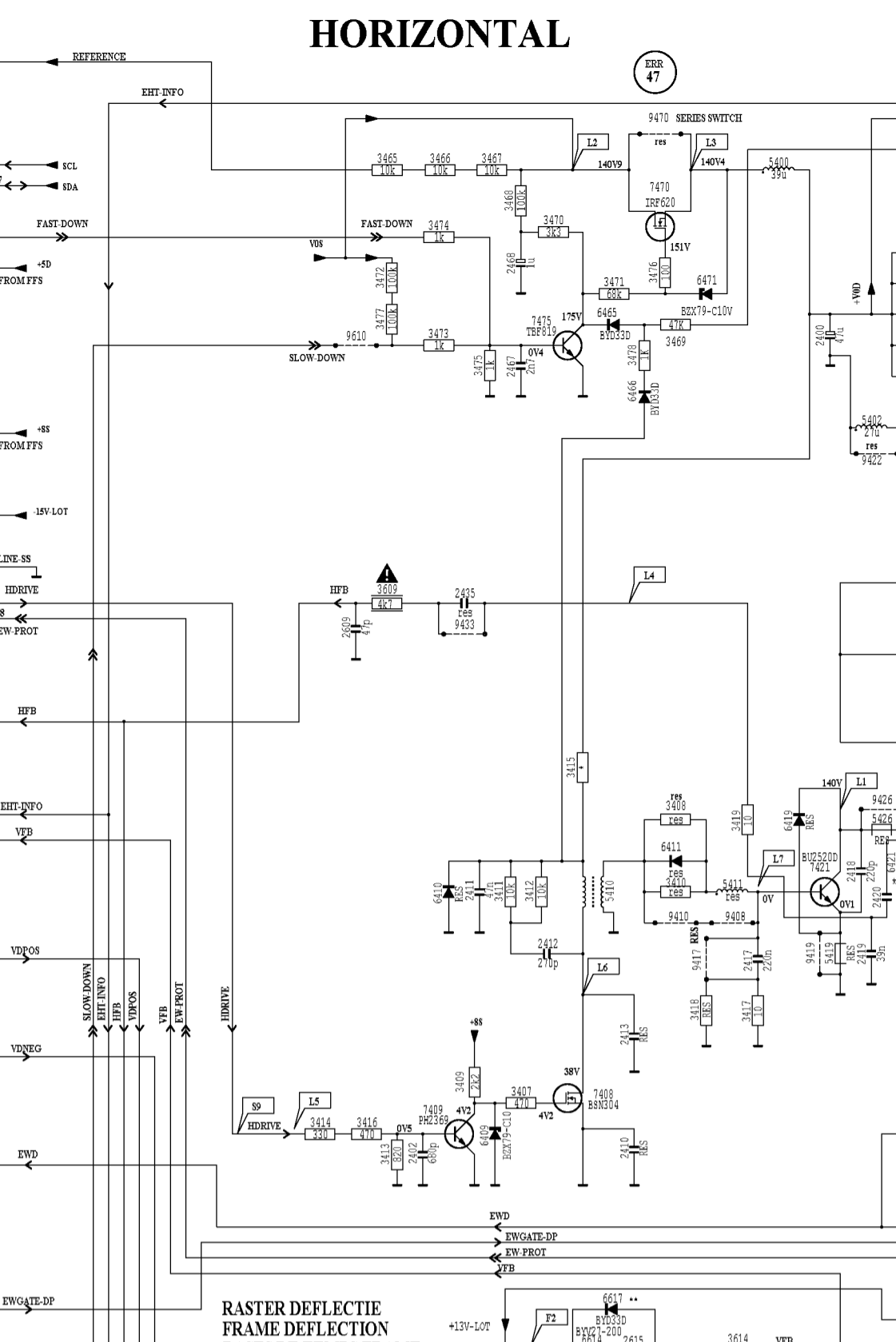
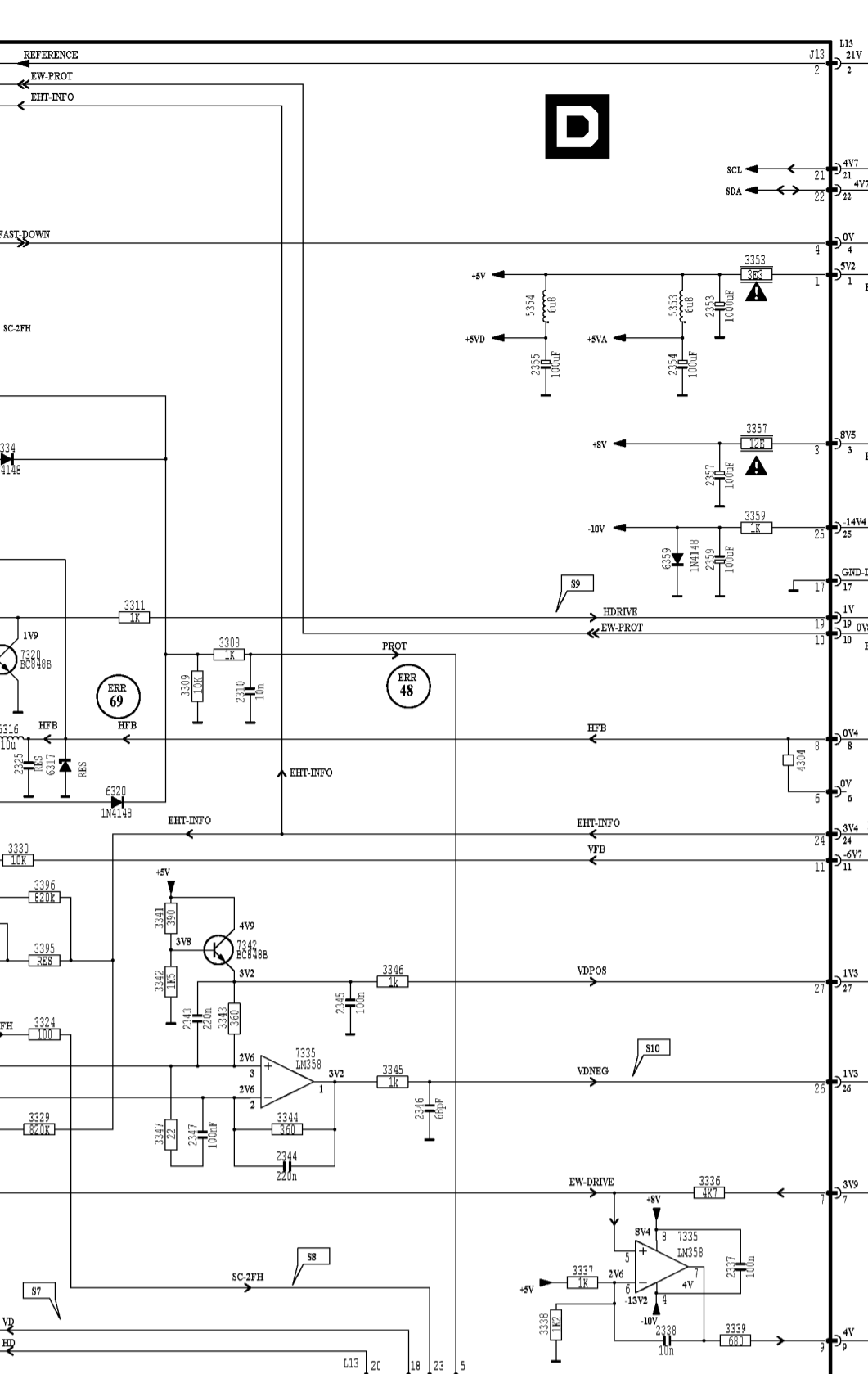
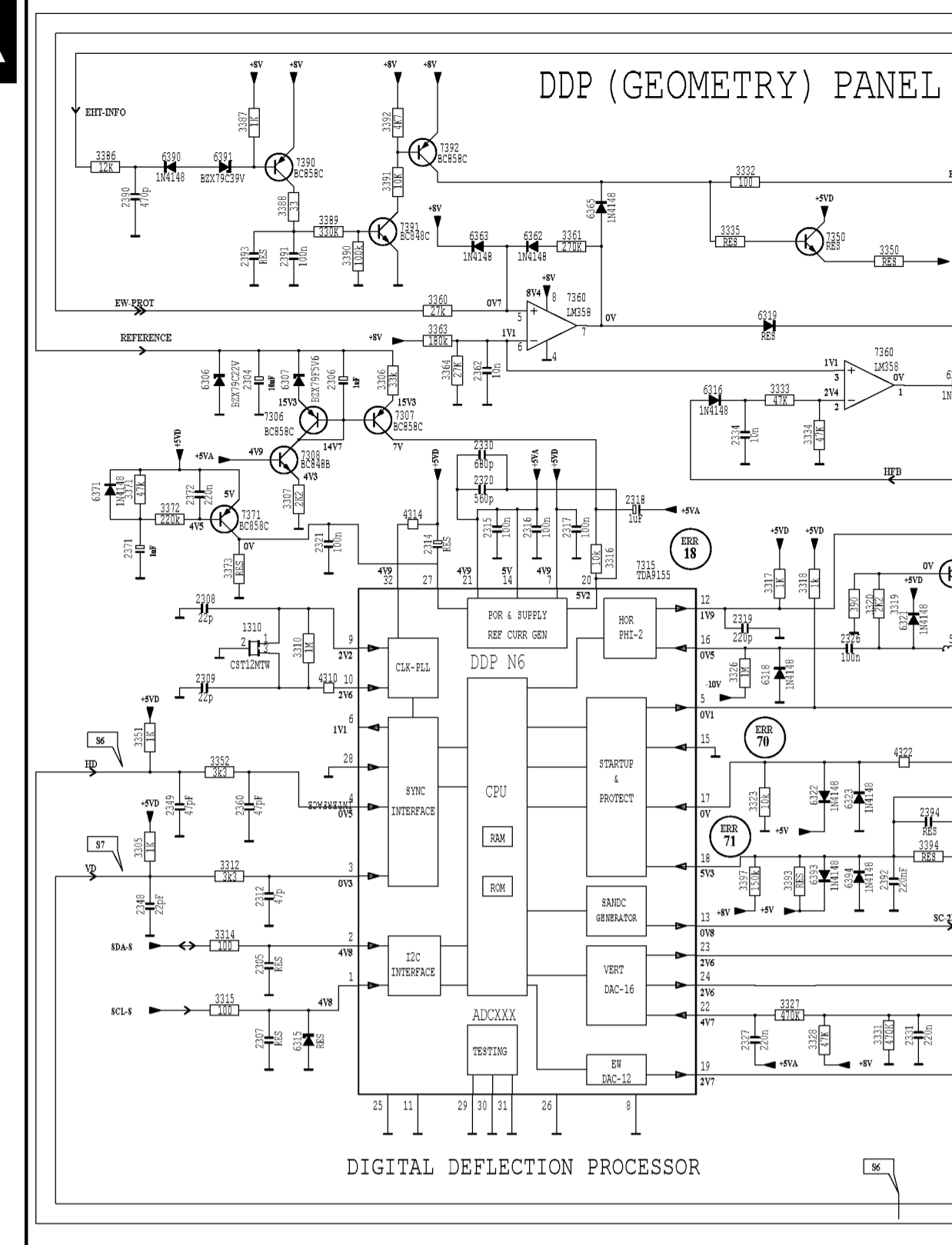

(\*) MEASURED IN STANDBY MODE

GELUID-EINDVERSTERKER  
SOUND POWER AMPLIFIER  
AMPLIFICATEUR FINAL AUDIO  
TONSIGNAL-ENDERSTAECKER  
AMPLIFICADOR FINAL DE AUDIO  
APPLICAZIONE DI POTENZA DEL SEGNALE SONOR

■ SUBWOOFER  
▲ HIGH SUBWOOFER  
♦♦♦ DOLBY DSP CONTROL (STYLING)  
♦♦♦ COBLESSE DOLBY PROTECT CONTROL (STYLING)

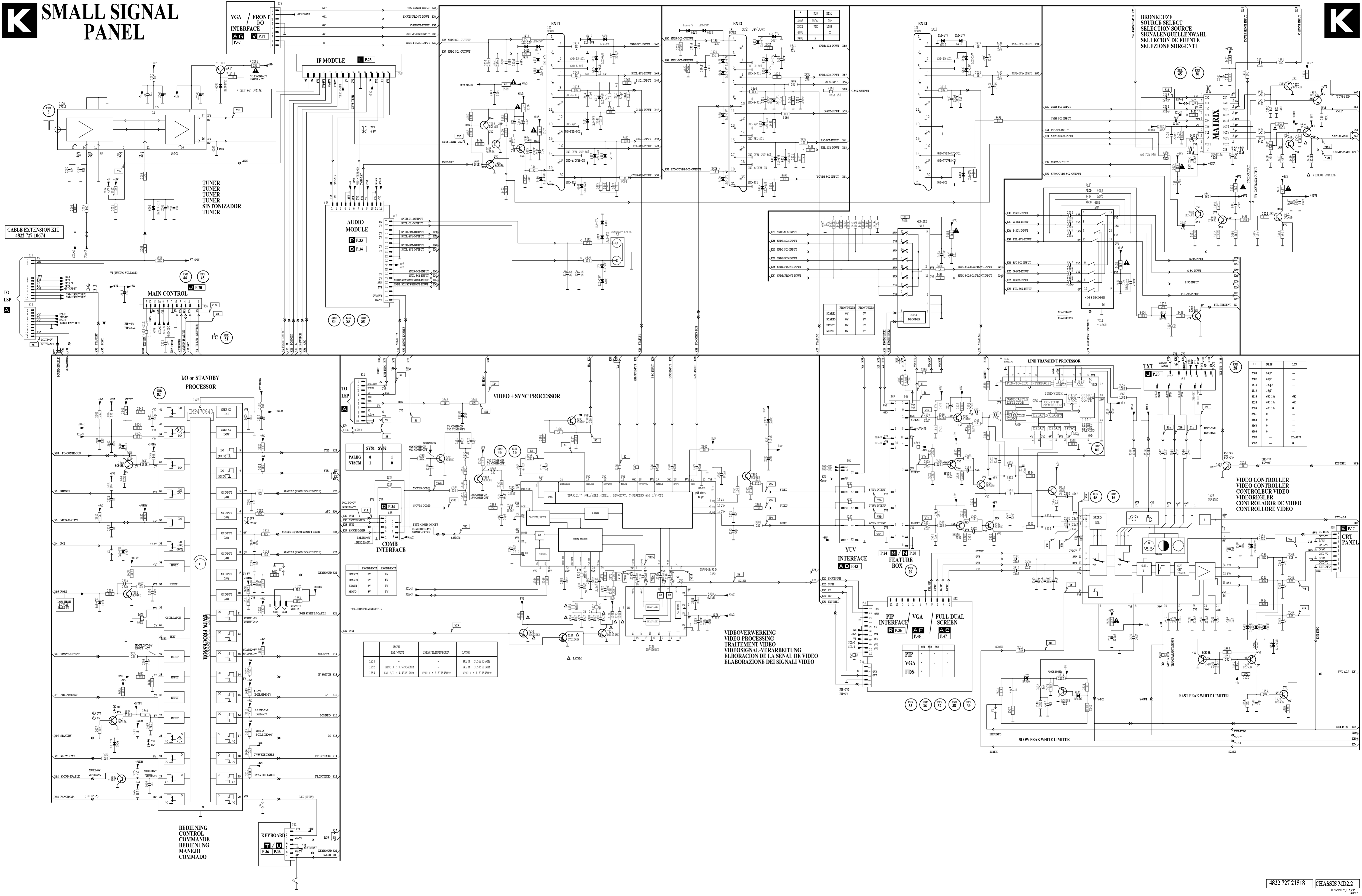

TUNER  
TUNER  
TUNER  
SINTONIZADOR  
TUNER

IF MODULE  
P.13

AUDIO MODULE  
P.33  
P.34

MAIN CONTROL  
P.20

IO or STANDBY  
PROCESSOR

VIDEO + SYNC PROCESSOR

COMB INTERFACE  
P.34

VIDEOOVERWERKING  
VIDEO PROCESSING  
TRAITEMENT VIDEO  
VIDEOSIGNAL-VERARBEITUNG  
ELABORACION DE LA SENAL DE VIDEO  
ELABORAZIONE DEI SIGNALI VIDEO

SECH	BAL/NELLI	DELMO/OLIVIERI/FURERA	LATM
1210	-	-	PAL N : 3.57515000
1232	NTSC M : 3.57515000	-	PAL N : 3.57515000
1254	PAL M/P : 4.43361000	NTSC M : 3.57515000	NTSC M : 3.57515000

YUV INTERFACE  
P.43

FEATURE BOX  
P.29

PIP INTERFACE  
P.36

VGA / FULL DUAL SCREEN  
P.46  
P.47

PIP  
VGA  
FDS

VIDEO CONTROLLER  
VIDEO CONTROLLER  
CONTROLEUR VIDEO  
VIDEOREGLER  
CONTROLORE VIDEO

FAST PEAK WHITE LIMITER

SLOW PEAK WHITE LIMITER

BEDIENING CONTROL  
COMMANDE  
BEDIENUNG  
MANEJO  
COMANDO

KEYBOARD  
P.36  
P.36