

Lage- und Verdrahtungsplan · Layout and Wiring Diagram · Plan de position et de câblage TR 300 hifi





6 BEREICHSDREHSCHALTER (ABS 6)

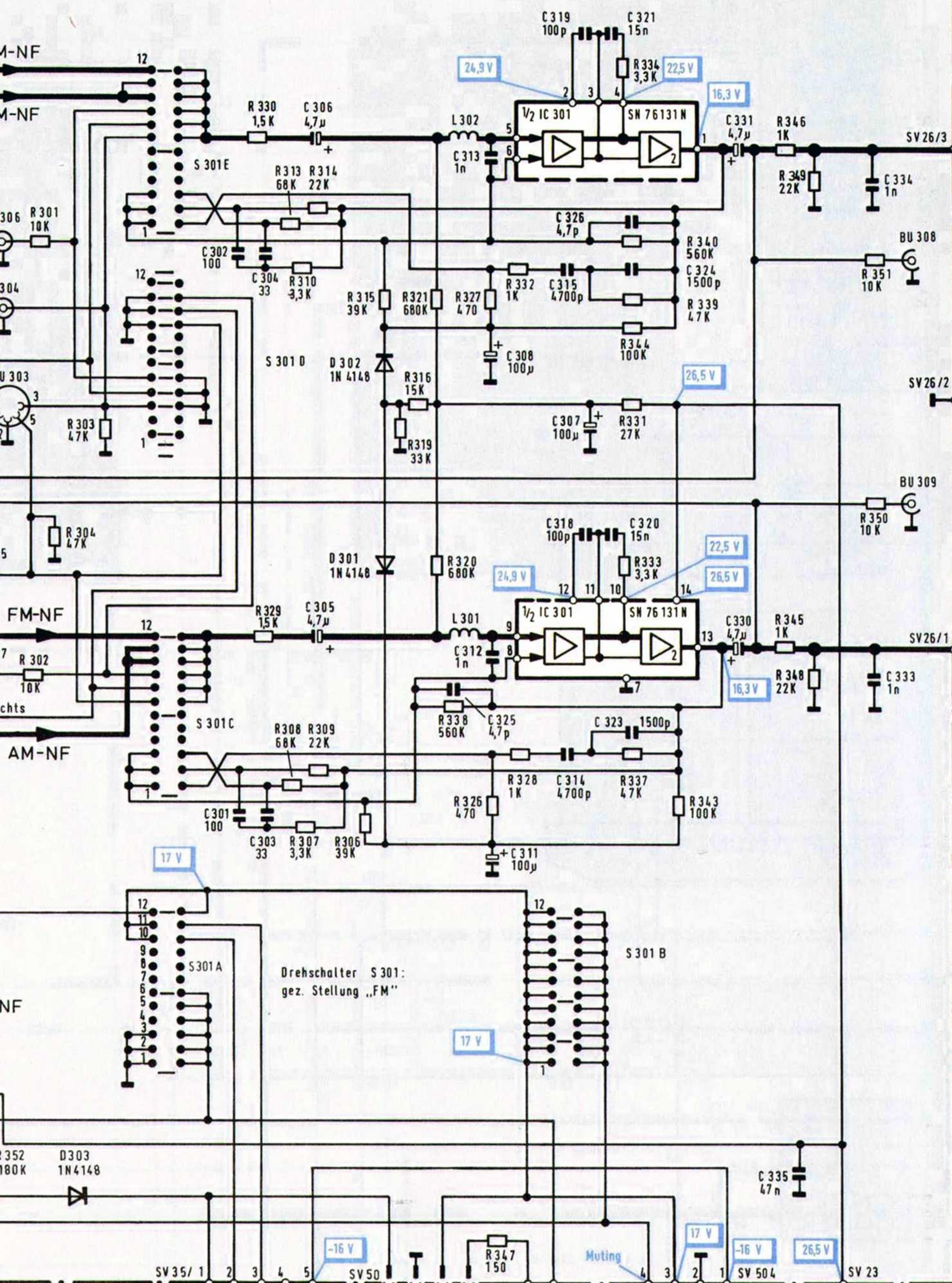

BS 5327 NF-SCHALTERPLATTE (ABS 8)

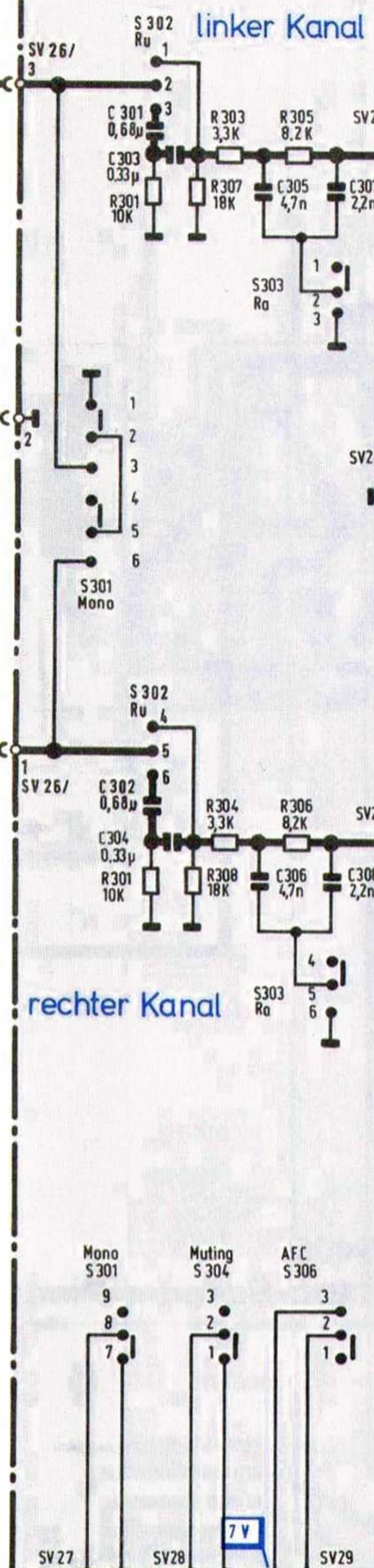

BS 5318 NF-EINSTELLER-PLATTE (ABS 7)

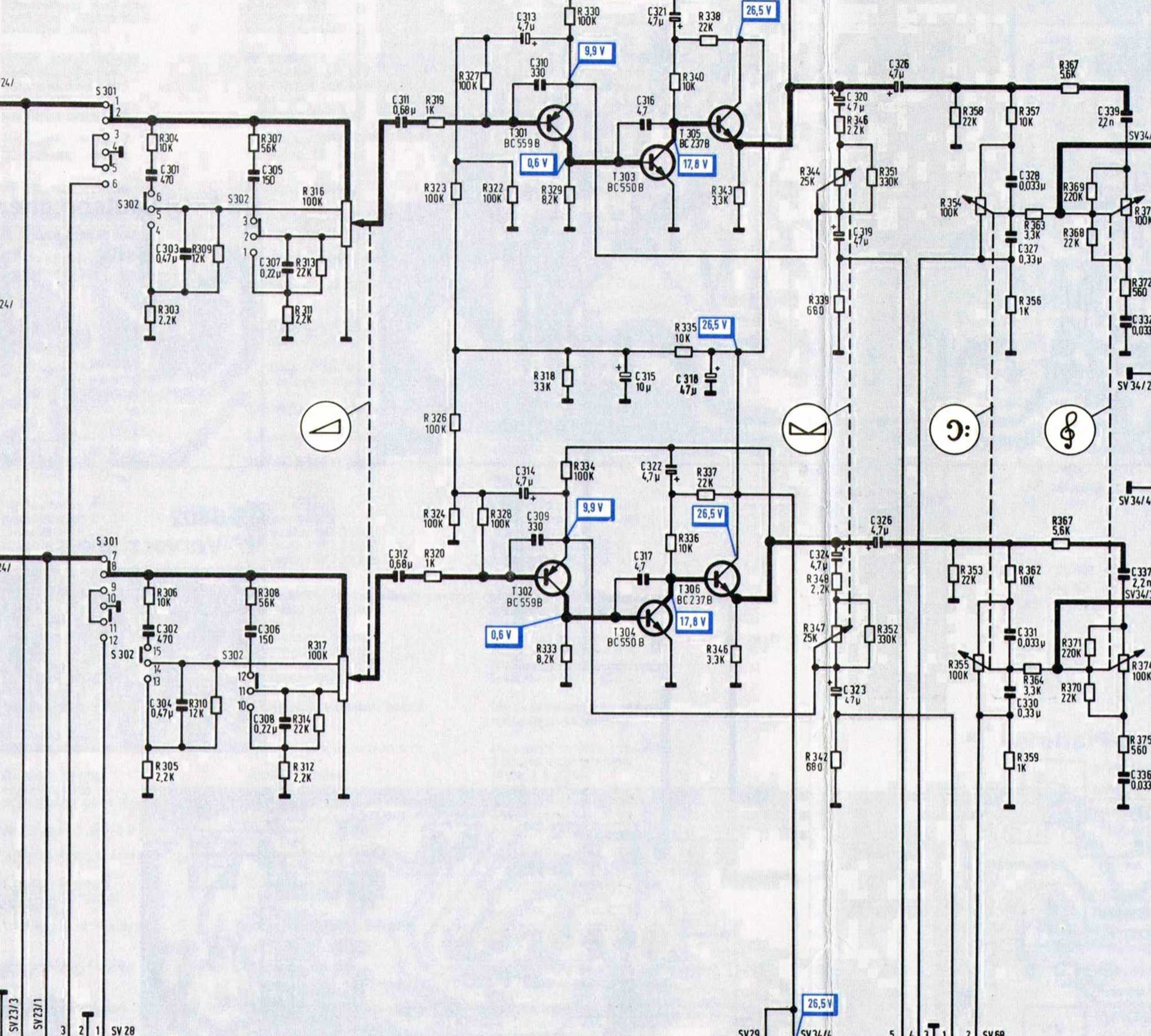

BS 5401 NF-ENDSTUFENPLATTE (ABS 9)

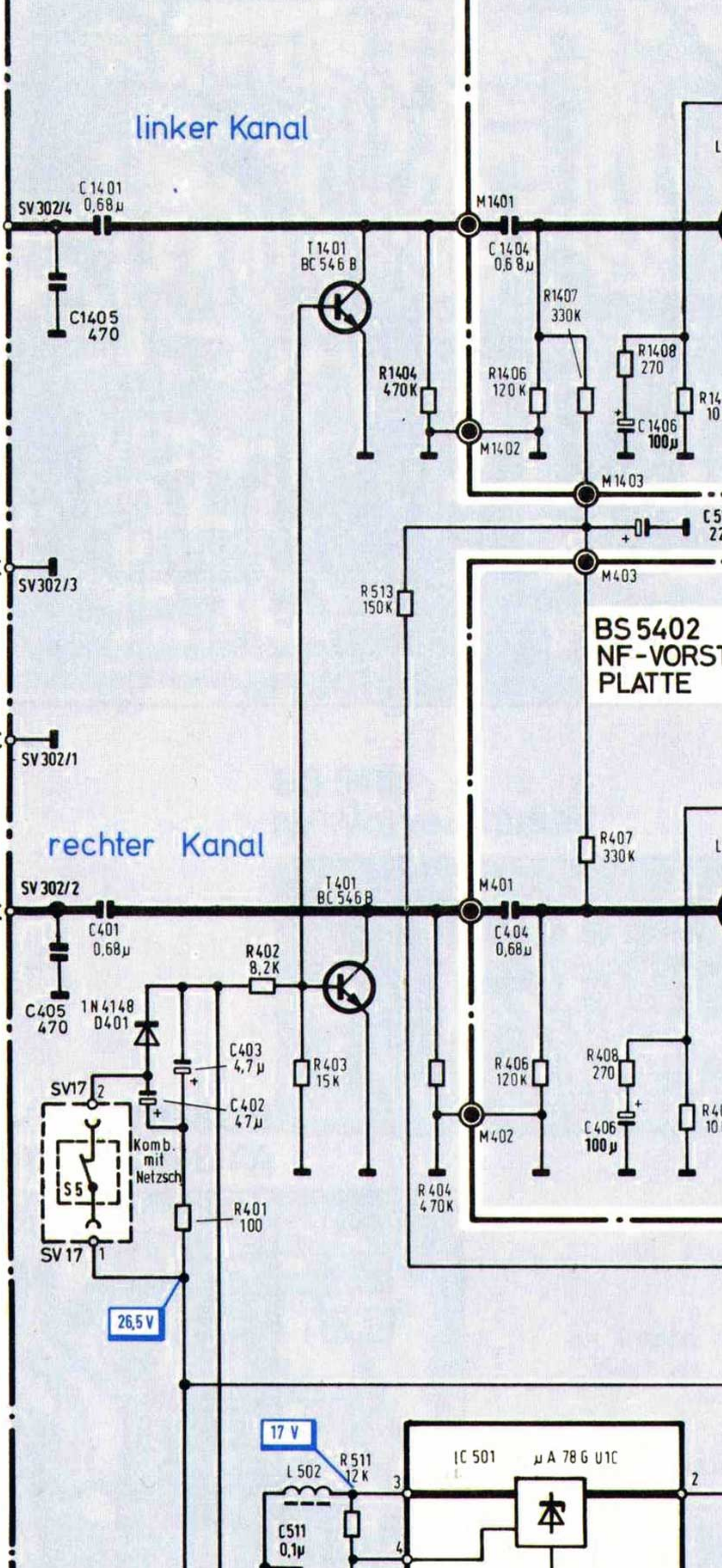

BS 5402 NF-VORSTUFEN-PLATTE

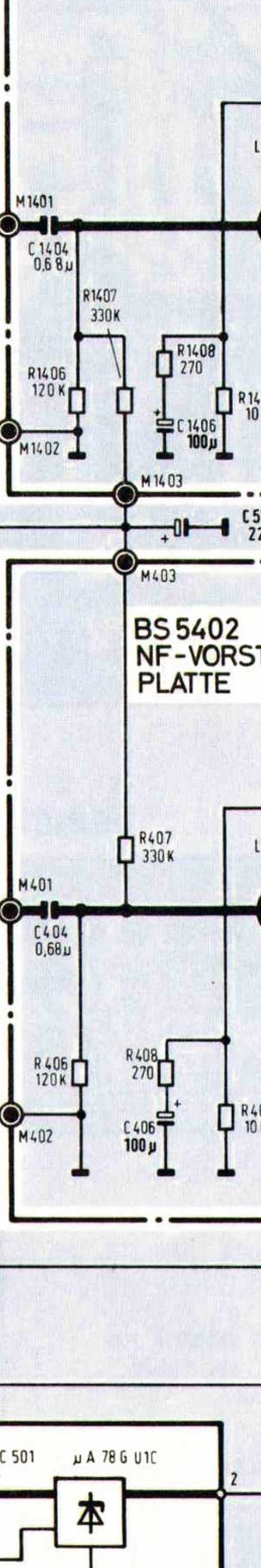

BS 5710 (ABS 303) INVERTERPLATTE

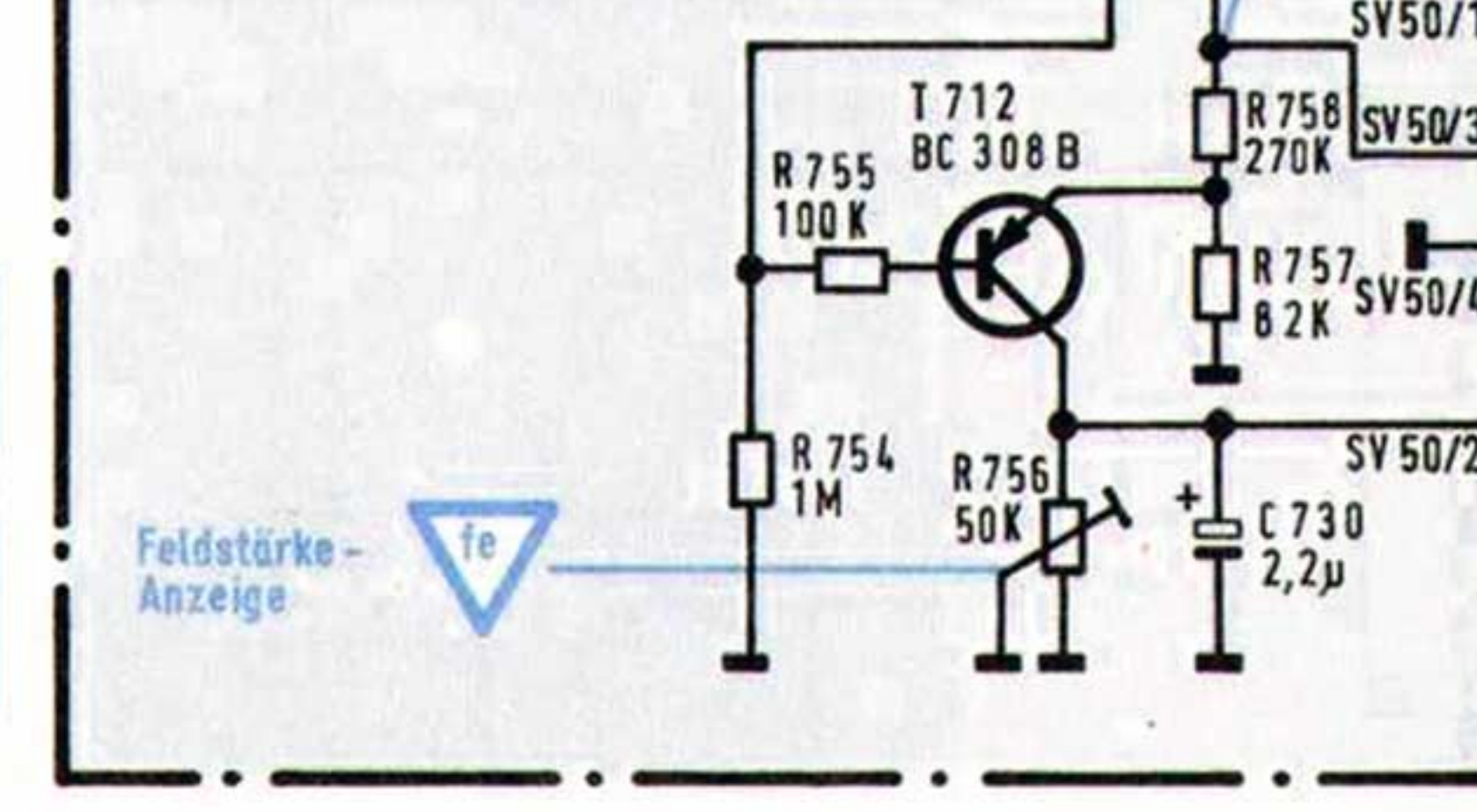

BS 5712 LED ANZEIGE (ABS 13)

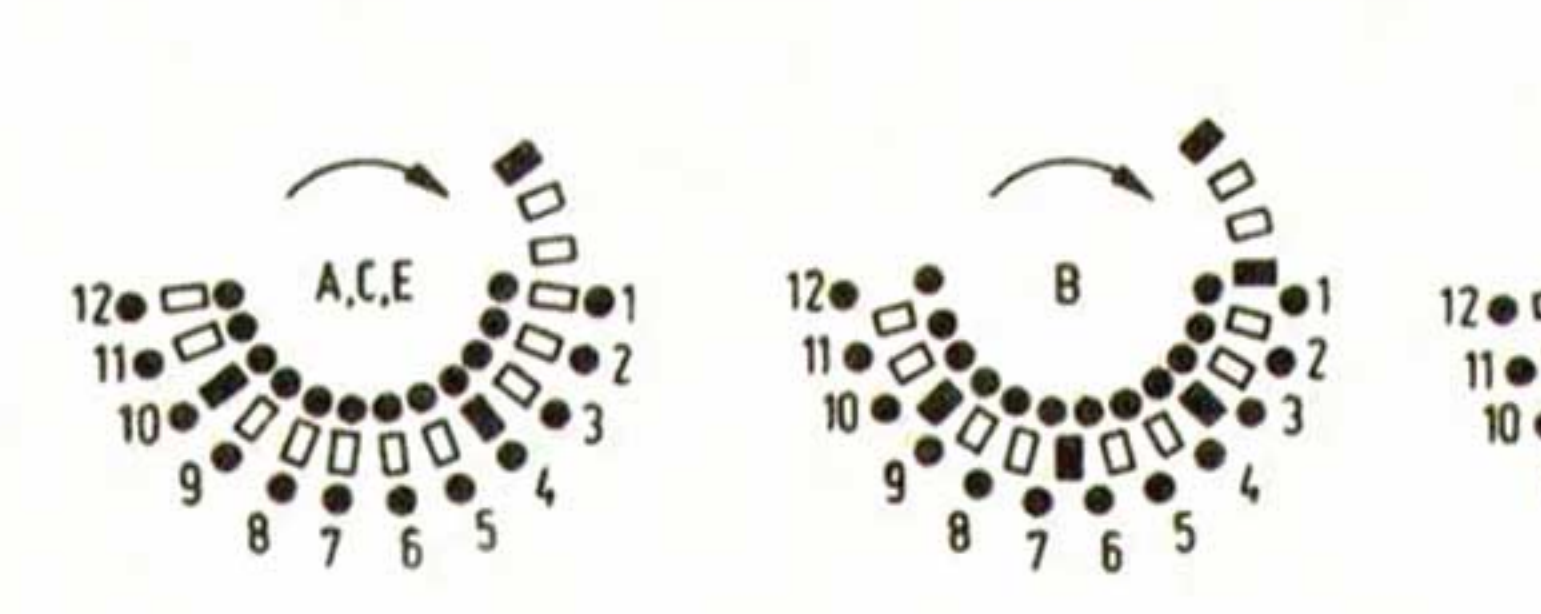
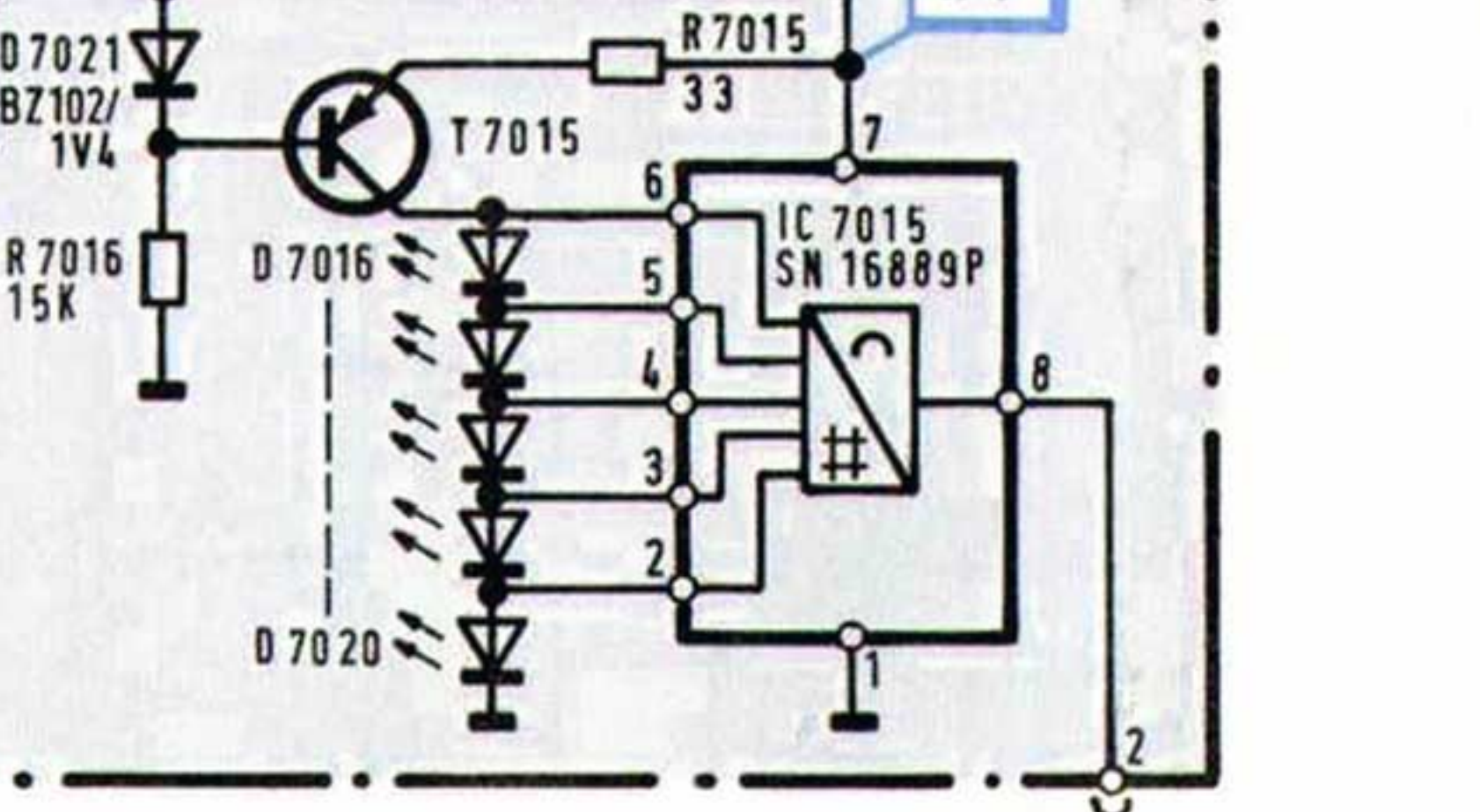

Rotary switch S 301
Seen from front of set
Shown in switch position LW
Switching sequence LW, MW, FM, PU, Tape, Aux

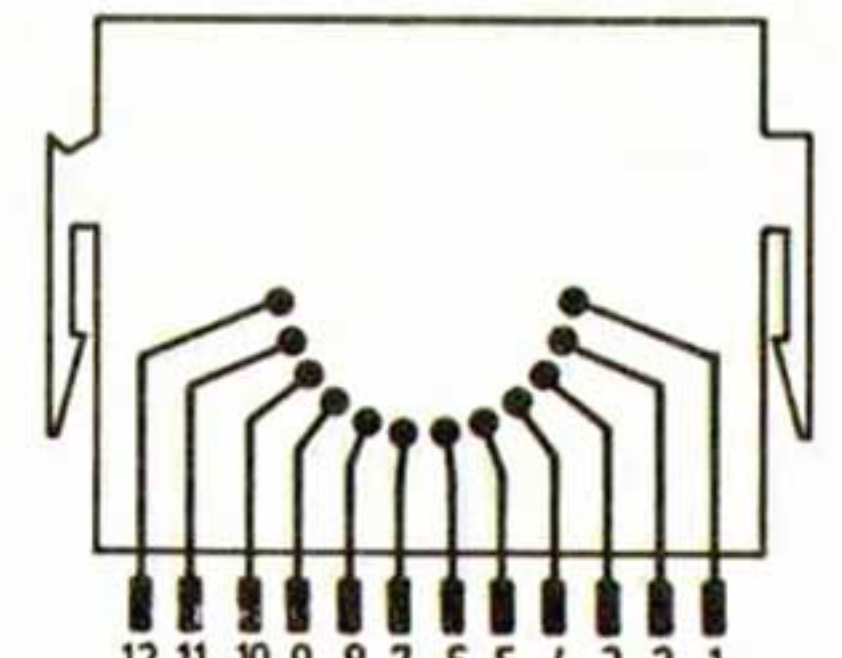

Commutateur S 301
rotatif vu de la chambre à cran d'arrière
Position du commutateur: LW
Ordre commutateur: LW, MW, FM, PU, Tape, Aux

Schalter von Lötseite gesehen,
alle Schalter in Ruhestellung.
Switches seen from soldering side.
All switches in neutral position.
Commutateur vu du côté soudure,
tous les commutateur en position
de repos.

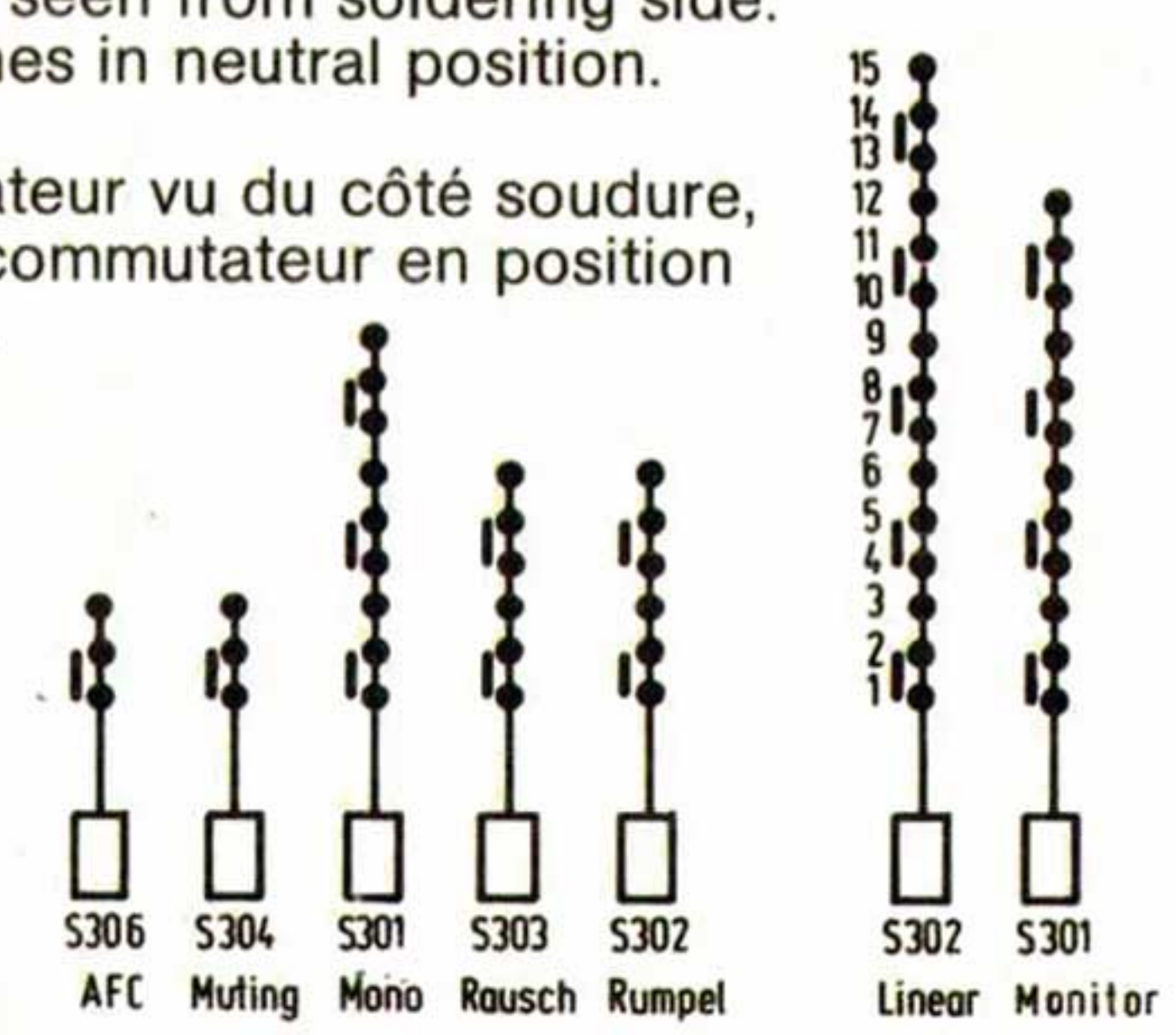

NF - Schalterplatte
BS 5327

NF - Einstellerplatte
BS 5318

BS 5510 (ABS 401) STROMVERSORGUNG -16V

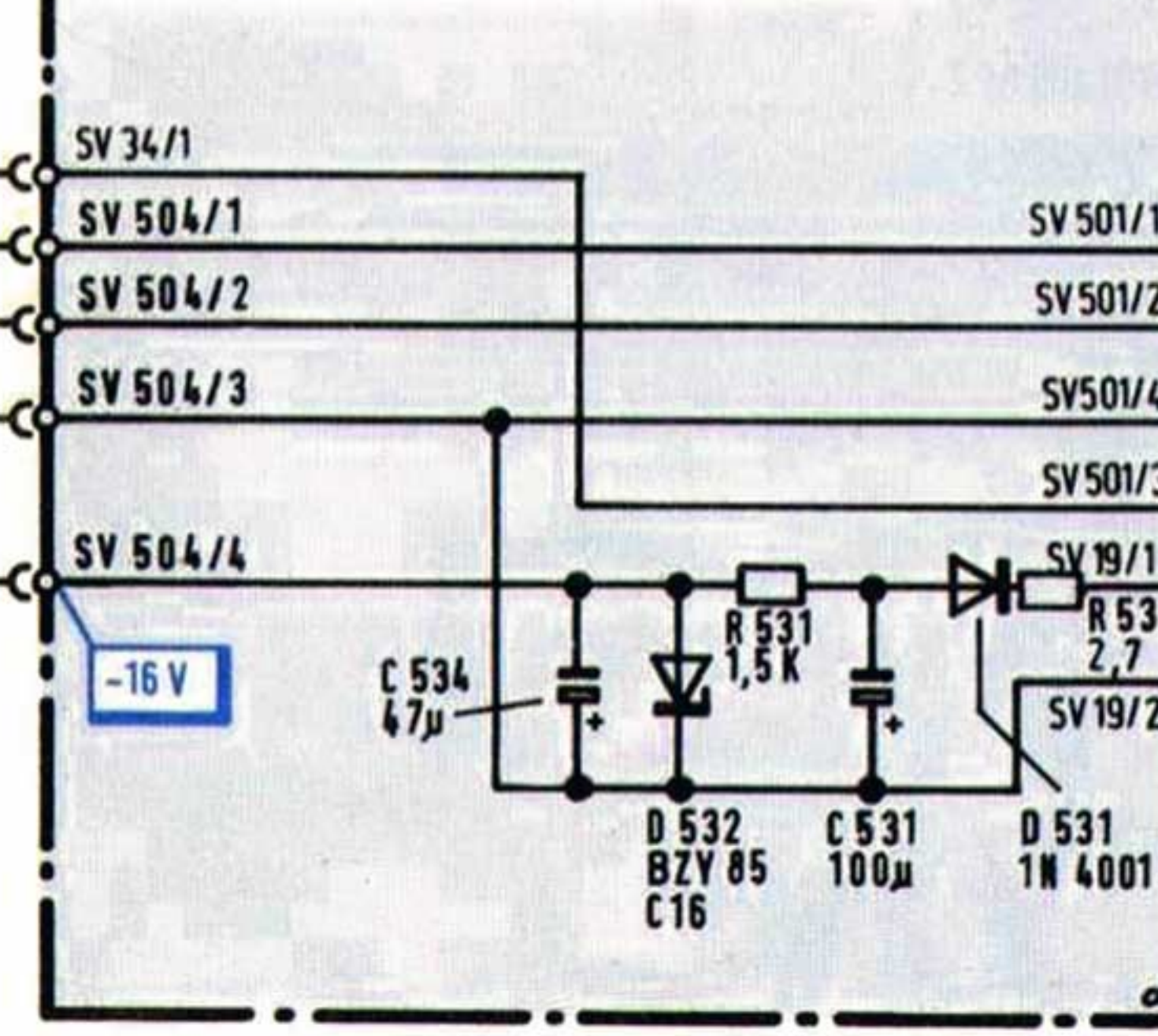

untere Abst.-Spg.
lower tuning voltage
Tension d'accord inférieure

obere Abst.-Spg.
upper tuning voltage
Tension d'accord supérieure

HIFI-CHASSIS 1000

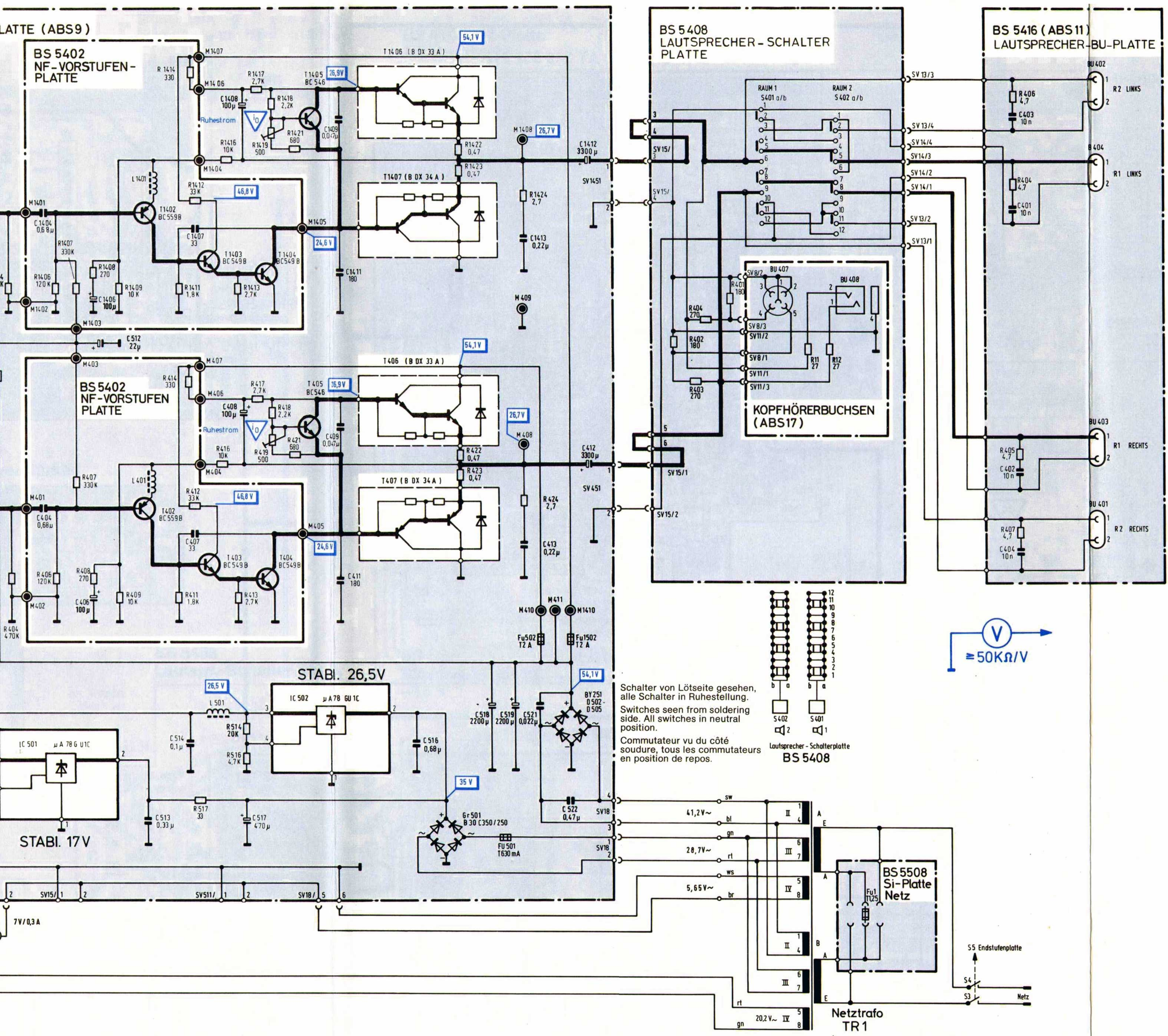

TR 300 hifi

- Stummabstimmung
Muting
Accord silencieux
- Übersprechdämpfung
Minimum crosstalk
Minimum de diaphonie
- Ruhestrom
Quiescent current
Courant sans signal
- Feldstärke-Anzeige
Tuning indicator
Indicateur de syntonisation

TR 300 hifi

Übersetzung · Translation · Traduction

- AM-Oszillator-Kreise
Circuits oscillateur AM
AM-Oscillateur Circuit
- AM-Oszillator/Mischstufe/ZF/Demodulator
Oscillateur AM/Etage Melangeur/FI/Demodulateur
AM-Oscillator/Mixer Stage/IF/Demodulator
- FM-Abstimmung
Accord FM
FM Tuning
- AM-Abstimmung
Accord AM
AM Tuning
- Abstimm-Spannung
Tension d'accord
Tuning Voltage
- NF links
BF gauche
AF - Left
- NF rechts
BF droite
AF - Right
- Decoder
Decodeur
Decoder
- FM - NF
FM - BF
FM - AF
- AM - NF
AM - BF
AM - AF
- FM-Vorstufe
Etage d'entree FM
FM RF Stage
- FM-Oszillator
Oscillateur FM
FM Oscillator
- FM-Mischstufe
Etage melangeur FM
FM Mixer Stage
- FM-ZF-Verstärker
Amplificateur FI-FM
FM-IF-Amplifier
- FM-ZF-Verstärker/Demodulator
Amplificateur FI-FM/Demodulateur
FM-IF-Amplifier/Demodulator
- AM-Vorkreise
Circuits d'entree AM
AM-RF Circuit

- VERSTÄRKER
AMPLIFIER
AMPLIFICATEUR
- VERST. (4-stufig)
AMPL. (4-stage)
AMPLI (4 étages)
- STEREO-SCHALTER
STEREO SWITCH
COMMUTATEUR STEREO
- PHASENVERGLEICH
PHASE COMPERATOR
COMPARATEUR DE PHASE
- GEREGLTER VERSTÄRKER
AMPLIFIER WITH AGC
AMPLI AVEC CAG
- MISCHSTUFE
MIXER STAGE
ETAGE MELANGEUR
- OSZILLATOR
OSCILLATOR
OSCILLATEUR
- GLEICHSPG.-VERSTÄRKER
DC-AMPLIFIER
AMPLI COURANT CONTINU
- DECODER-SCHALTER
DECODER SWITCH
COMMUTATEUR DU DECODEUR
- STABILISIERUNG
STABILISATION
STABILISATION
- FREQUENZ-TEILER
FREQUENCY-DIVIDER
DIVISEUR DE FREQUENCE
- LAUTSTÄRKE
VOLUME
- STUMMABSTIMMUNG
MUTING
ACCORD SILENCIEUX
- SCHWELLVERT-SCHALTER
LEVEL SWITCH
COMMUTATEUR VALEUR SEUIL CAG
- BALANCE
- BEGRENZER (4-stufig)
LIMITER (4-stage)
LIMITEUR (4 étages)
- GLEICHRICHTER
RECTIFIER
REDRESSEUR
- HÖHEN
TREBLES
AIGUS
- DEMODULATOR
DEMODULATEUR
DEMODULATEUR
- ANALOG-DIGITAL-WANDLER
- TIEFEN
BASSES
GRAVES