

SERVICE MANUAL
LINEAR TRACKING TURNTABLE
MODEL LT-20

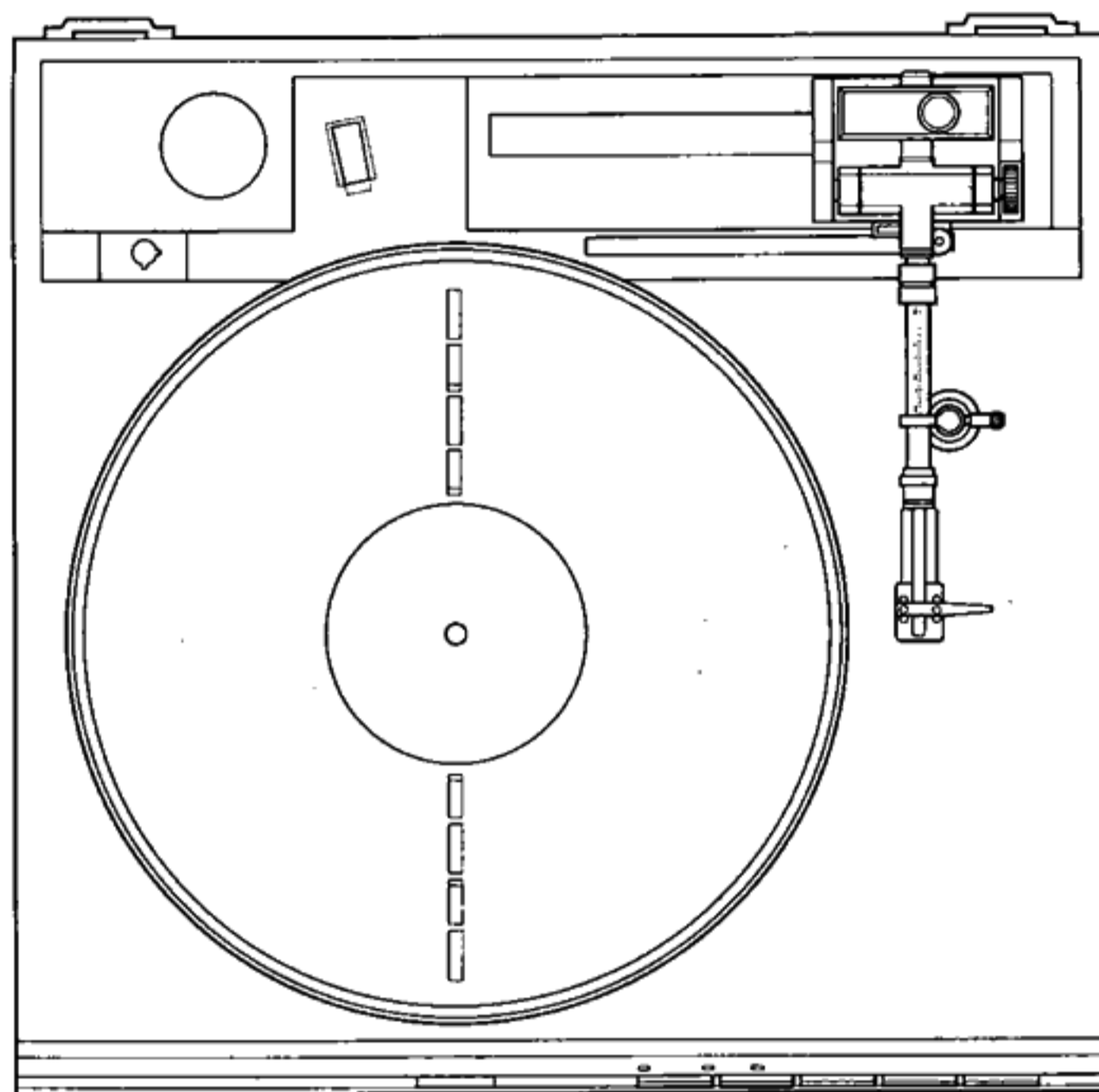

CONTENTS

IDENTIFICATION AND OPERATION	2
SCHEMATIC REPRESENTATION OF LT-20 AUTOMATIC FUNCTIONS	2
SPECIFICATIONS	3
DISASSEMBLY INSTRUCTIONS	3
ADJUSTMENTS	4
INTERNAL DIAGRAMS AND PINOUT OF INTEGRATED CIRCUITS	8
INFORMATION ON LOGIC IC (MSM-5831RS)	10
WIRING DIAGRAM	11
PRINTED CIRCUIT BOARDS	13
SCHEMATIC DIAGRAM	15
EXPLODED VIEW	17
PARTS LIST	18
PACKING INSTRUCTIONS	20

IDENTIFICATION AND OPERATION:

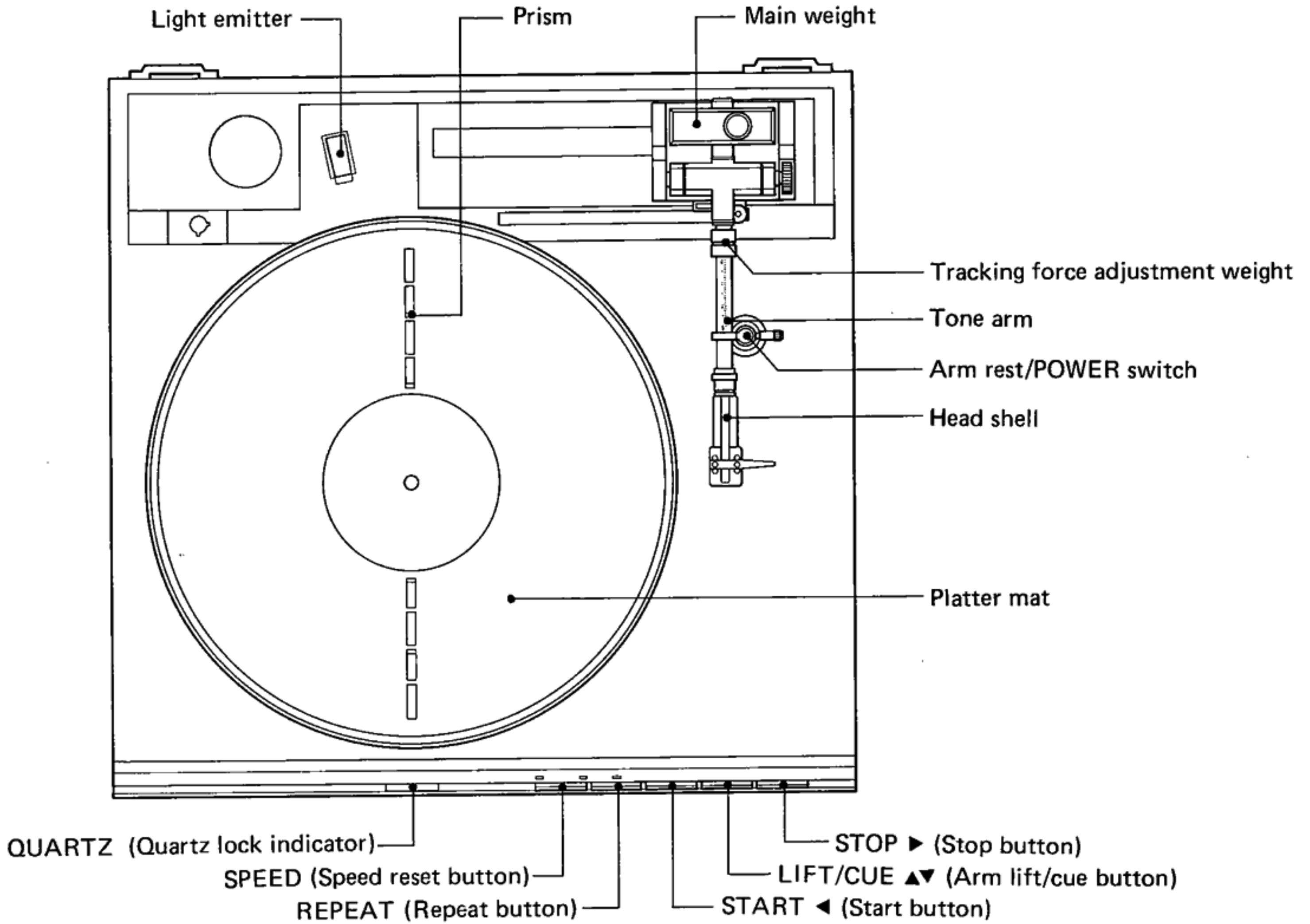

SCHEMATIC REPRESENTATION OF LT-20 AUTOMATIC FUNCTIONS

<p>Power on: turn the locking arm of the arm rest in a counterclockwise direction. Tonearm becomes free.</p>		<p>Stylus-lift priority: press (▲▼) to reverse stylus descent. Stylus ascent cannot be reversed before completion.</p>	
<p>Auto lead-in: press the start (◀) button once to commence audition.</p>		<p>Free travel: press (◀) and (▶) buttons to move the tone arm in either direction, then (▲▼) to lower it.</p>	
<p>Auto return: the tone arm returns automatically at the end of the disc.</p>		<p>Return: if, while pressing (▶) the tone arm moves over the edge of the disc, it will return rapidly to rest.</p>	
<p>Auto cut: press the stop (▶) button once to interrupt and end disc audition.</p>		<p>Quick response: any movement except lift/cue of the stylus can be interrupted by a new command.</p>	
<p>Free access lead-in: continue to press the start (◀) button and the tone arm will travel on over the disc until pressure is released. Press the lift/cue button (▲▼) to lower it.</p>		<p>Stylus protection: when there is no disc on the platter, the stylus will not descend, and the tone arm will return to rest.</p>	
<p>Repeat: pressing the repeat button turns the repeat function alternately on and off. When on, the indicator lights.</p>		<p>Manual lead-in: first switch on the platter motor, then lift the stylus over to the lead-in groove.</p>	
<p>Lift-up and cueing: pressing the lift/cue (▲▼) button alternately lowers and raises the tone arm.</p>		<p>Manual lead-out: lift the stylus and return the tone arm to the rest position. The platter will stop automatically.</p>	

SPECIFICATIONS:

1. PHONO MOTOR SECTION

Drive system	Direct drive
Motor	Quartz PLL DC servo motor
Platter Diameter	304mm (11-15/16")
Weight	1.3 kg (2.9 lbs)
Material	Aluminum diecast
Platter speed	33-1/3, 45 rpm
Wow and Flutter	0.025% (Wrms)
	±0.04% Wp-p, DIN 45-507
Signal to noise ratio	78 dB (DIN-B)
	65 dB (IEC-B)

2. TONEARM SECTION

Type	Straight type universal, static balance
Overall length	220 mm (8-11/16")
Effective length	171 mm (6-3/4")
Tracking error	Maximum 0.1°
Head shell	GFRP 6.2 g
Cartridge weight range	10–18g w/head shell

3. GENERAL

Power consumption	14 W
Dimensions (W x H x D)	424 x 142 x 417 mm (16-3/4 x 5-5/8 x 16-3/8")
Weight	10 kg (22 lbs)

Design and specifications are subject to change without notice for improvement.

DISASSEMBLY INSTRUCTIONS:

1. Removal of Front Panel

- 1) Remove the nine screws securing the bottom cover.
- 2) Remove the three screws (with washers) shown in Fig. 1.
- 3) The front panel can now be removed.

2. Removal of Tonearm Ass'y

- 1) Detach the E-ring and coil spring. Remove the slit plate by lifting point (A) slightly upwards and shifting the plate in the direction of arrow (B) (Shown in Fig. 2).
- 2) Loosen the wire holder on the tonearm's relay P.C.B.
- 3) Remove the two screws (1) securing the light receiving P.C.B. that functions to sense the tonearm position. Take off the P.C.B. holder, moving it in the direction of arrow (C).
- 4) Unsolder the six lead wires (white, blue, red, green and two black from left to right in the figure) leading out from the tonearm shaft.
- 5) Disconnect CONN-4 of the main P.C.B. and separate it from the other wires.
- 6) After removing the two screws (2), the tonearm ass'y can be removed by moving it upwards.
- 7) The tonearm can now be removed from the arm base and replaced.

NOTES

1. Except when it is necessary to remove the tonearm's horizontal movement mechanism (D) and lead wires, them as they are.
2. When attaching the P.C.B. holder during re-assembly, be careful not to pinch the lead wires from the tone arm.

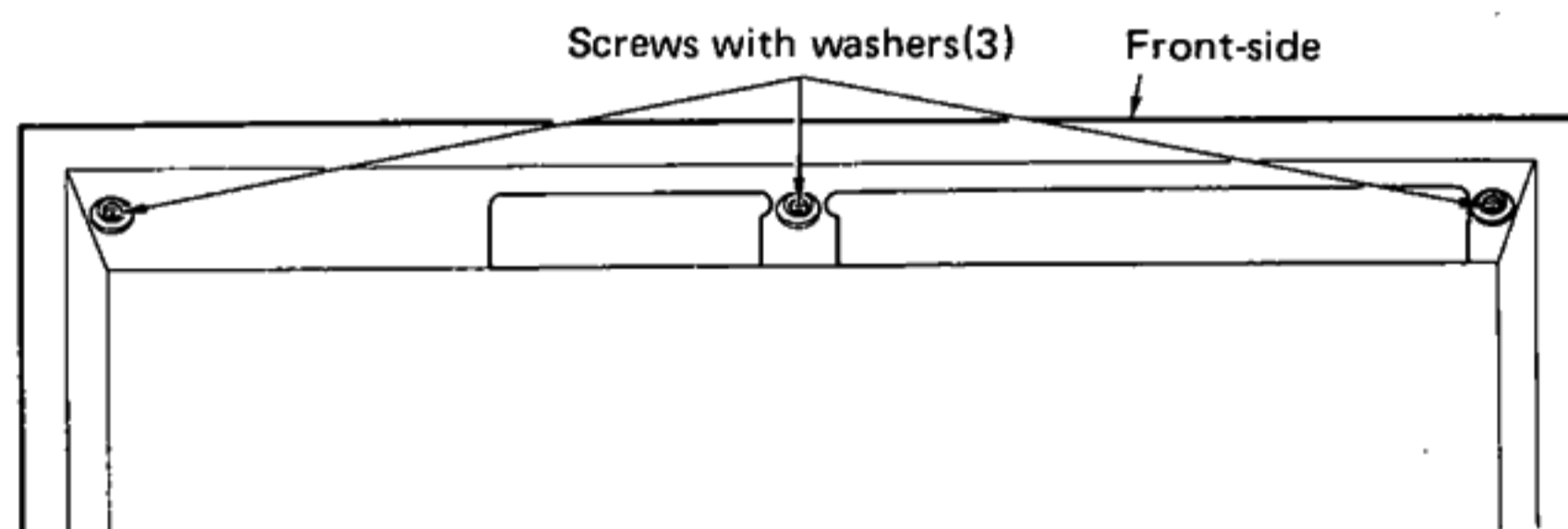

Fig. 1

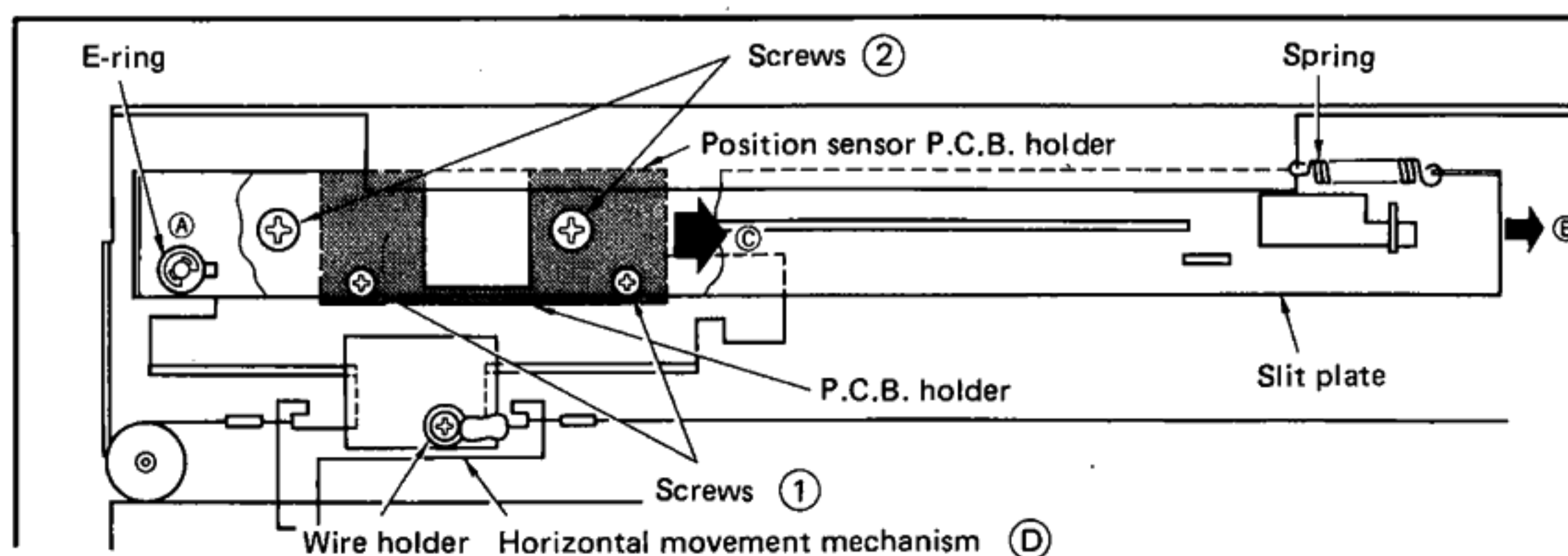

Fig. 2

3. Upon completion of assembly, twist the wires leading out from the tonearm's movable section to prevent.
4. After replacing the tonearm, be sure to perform tonearm adjustments.

ADJUSTMENTS:

1. Tracking Force Adjustment

- 1) Set the tracking force weight to the "0" position on the tonearm.

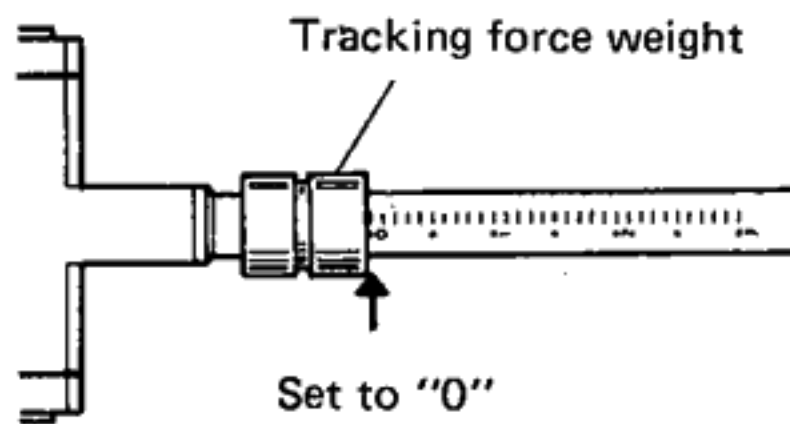

Fig. 3

- 2) Turn the power switch ON.
- 3) While lightly supporting the front of the head shell rotate the adjustment knob for the main weight until zero balance is achieved. See Fig. 4 below.

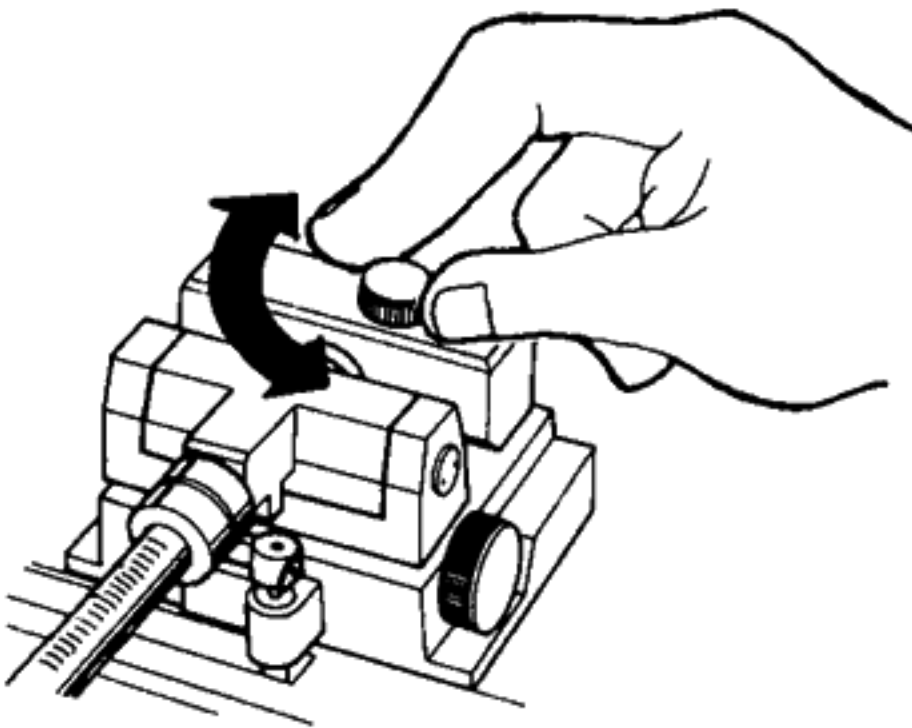

Fig. 4

- 4) Return the tonearm to the arm rest. Adjust the tracking force weight to the desired weight. See Fig. 5

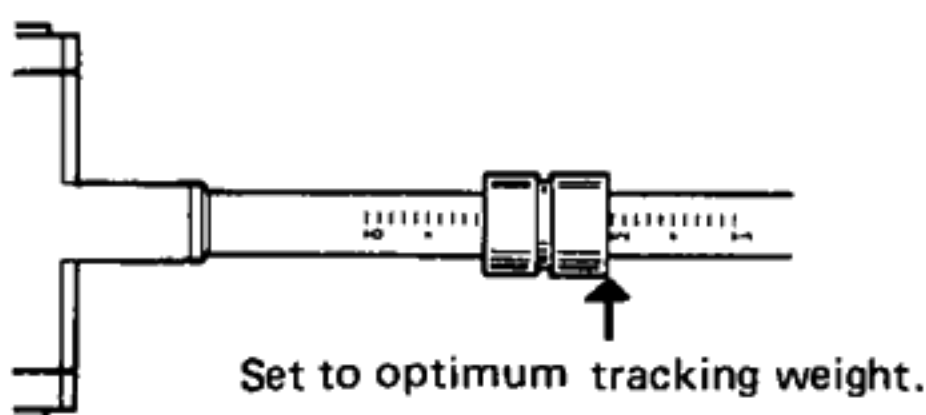

Fig. 5

NOTE:

Adjustments 2, 3, and 4 should always be done in sequence.

2. Tonearm Height Adjustment

- 1) Provide power to the unit.
- 2) Turn the power switch ON.
- 3) Loosen the arm height adjusting screw, by turning it counterclockwise. Then, after lifting the arm holder as high as it will go, secure it.
- 4) Place a (30 cm LP) record on the platter.
- 5) While maintaining the tonearm in the up position with one hand, depress the ◀ (START) button with the other to lower the tonearm.
- 6) Turn the power switch OFF.
- 7) With the set in this condition, adjust the tonearm so that it becomes level. While holding the arm holder, position the arm pipe parallel to the record surface and then secure it in place by turning the arm height adjusting screw in a clockwise direction. See Fig. 6 and 7 below.

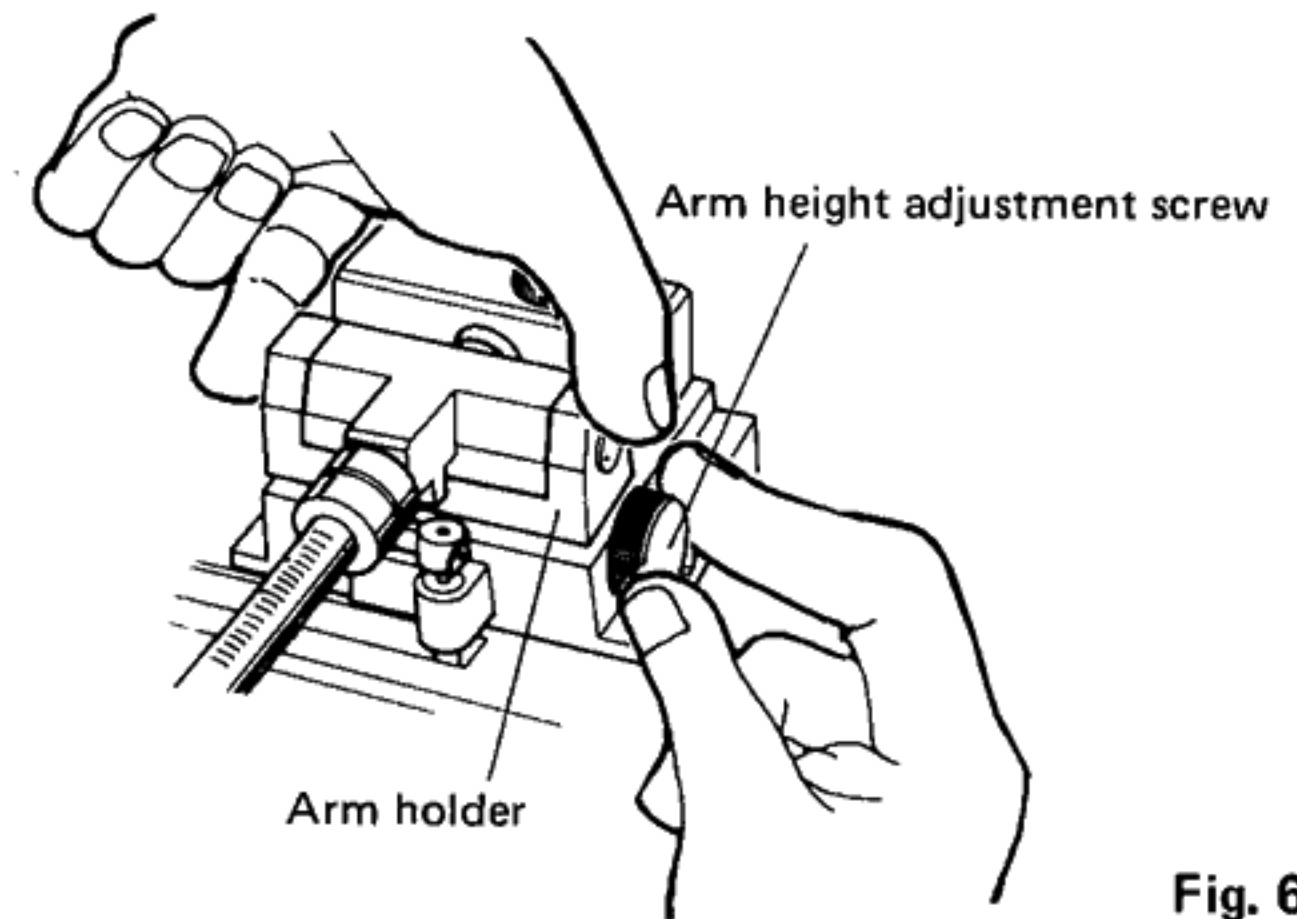

Fig. 6



Fig. 7

- * Be sure to perform adjustment 3 (Stylus Height Adjustment) after completing the steps above.

3. Stylus Height Adjustment

- 1) After completing adjustment of the tonearm height, turn on the power switch. With the set in the "Play" mode, depress the ▲▼ (LIFT/CUE) button, which will cause the tonearm to be lifted up.
- 2) The height obtained at this point will be the stylus height. The optimum height should be 5 mm (1/5") if it is other than this the Stylus Height Adjustment must be made using a hexagon wrench.* See Fig. 8.

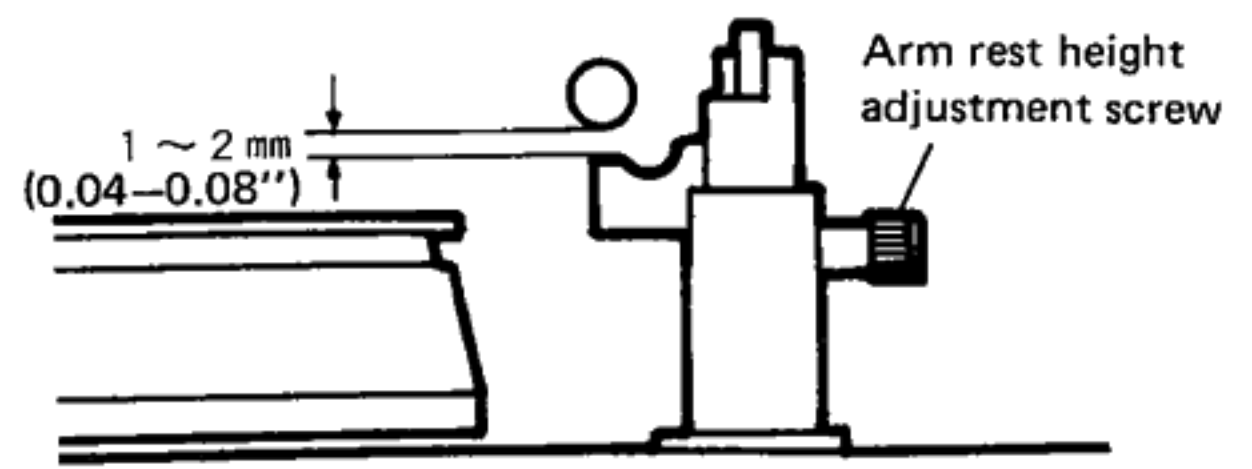

Fig. 9

NOTES

1) If the stylus height is too low

When the tonearm moves horizontally, the stylus will tend to come in contact with the record surface or platter.

2) If the stylus height is too high

Adjusted to a height decidedly higher than the proper one, the stylus will float at low portions of a warped record.

5. Adjustment of Lead-in Position

The cover label shown in Fig. 10 must be taken off prior to adjusting the lead-in and rest position.

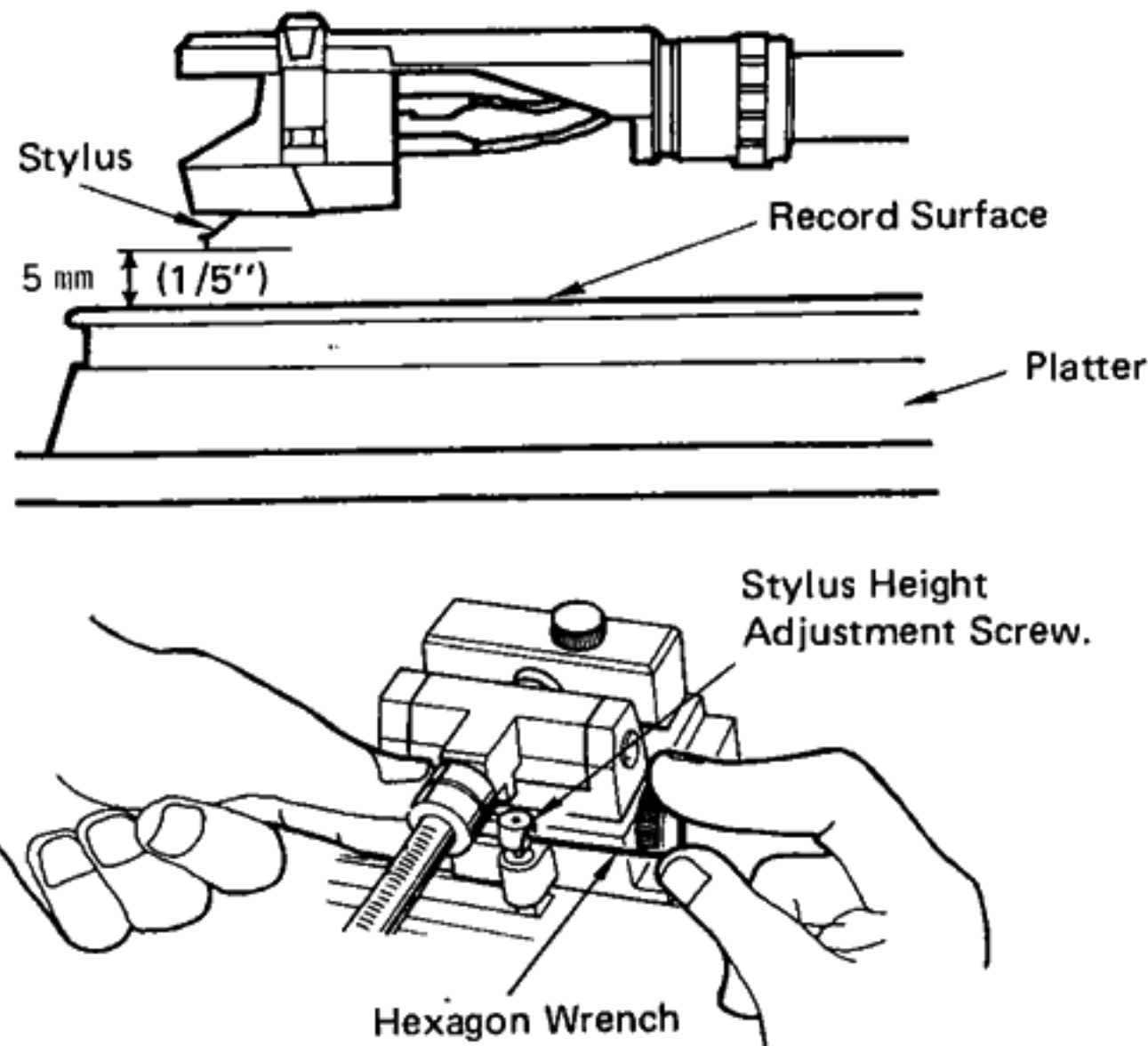

Fig. 8

* During adjustment, use care not to allow the hexagon wrench to fall into the mechanism.

4. Arm Rest Height Adjustment

Upon completion of Tonearm and Stylus height adjustments the Arm rest height must be checked as shown in Fig. 9. If adjustment is necessary follow the steps below.

- 1) Loosen the arm rest height adjustment screw and move the arm rest to the lowest position.
- 2) Depress the ► (STOP) button and return the tonearm to the arm rest.
- 3) Depress the ▲▼ (LIFT/CUE) button and lift up the tonearm. At this point, shift the tonearm a little towards the center spindle, and by moving the arm rest vertically, adjust it so that there will be a clearance of 1 ~ 2 mm between the tonearm and the flat portion of the arm rest. Secure the arm rest by tightening the arm rest height adjustment screw.

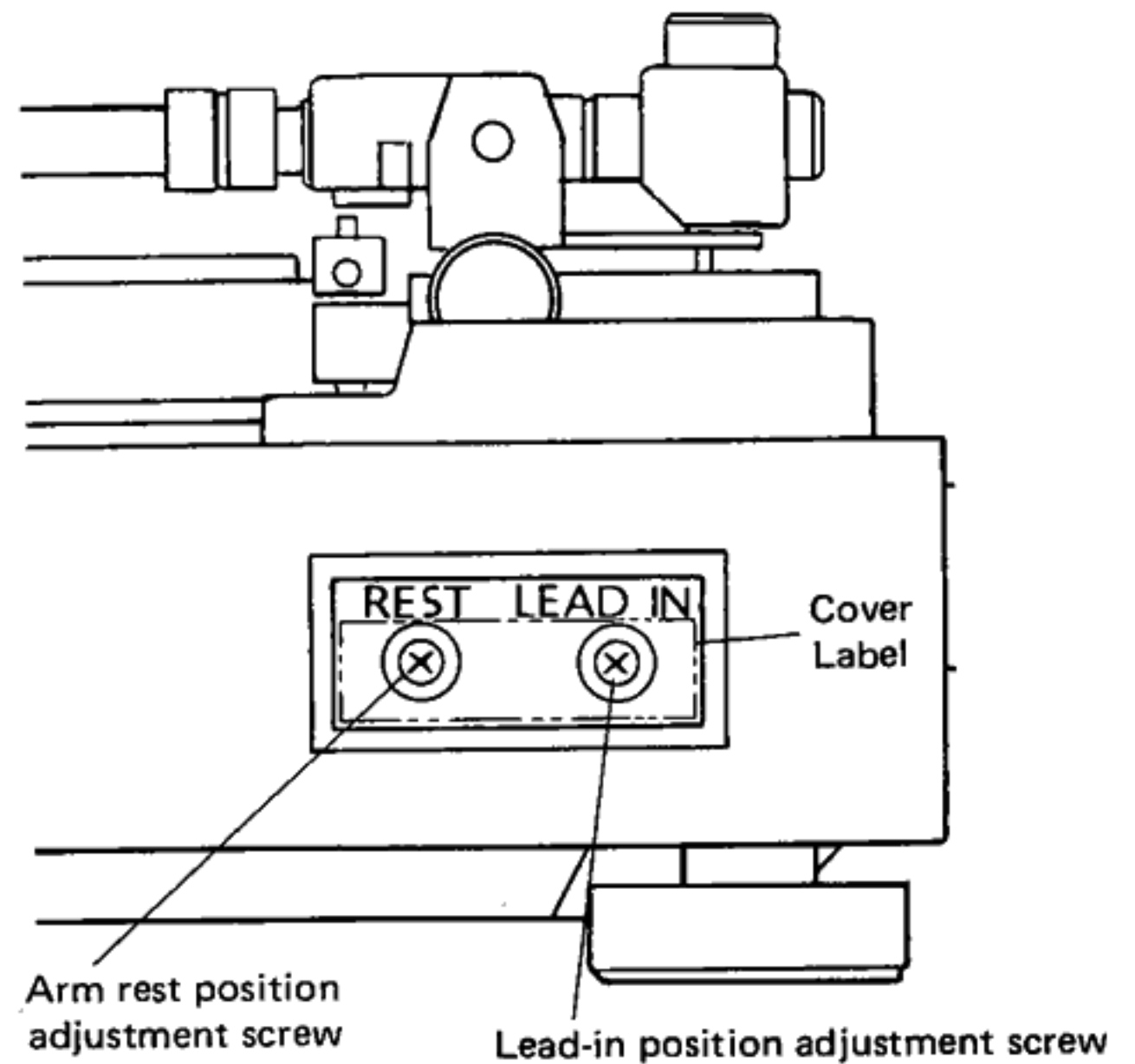

Fig. 10

- 1) With a 30 cm (12" LP) record placed on the platter, depress the ◀ (START) button and observe the lead-in to see to which side the stylus is off-position.
- 2) Turn the lead-in position adjustment screw a little using a screwdriver. Depress the ► (STOP) button and return the tonearm to the arm rest.
- 3) Depress the ◀ (START) button and check the lead-in position again. If it is still improper, repeat Step 2).
- 4) After adjusting the lead-in position to the optimum one with a 30 cm record, repeat the same adjustment with a 17 cm (7") record.

NOTES

- 1) Care should be used during adjustment as not to damage the stylus as it may set down outside of the record surface.
- 2) Be careful not to set the lead-in position too far inward. This may cause improper pick-up sensing.

6. Rest Position Adjustment

- * When returning the tonearm to the arm rest, if the arm does not set properly into the notch in the arm rest (hits either the right or left side of the arm rest during descent), perform the following adjustments. See Fig. 11 below.

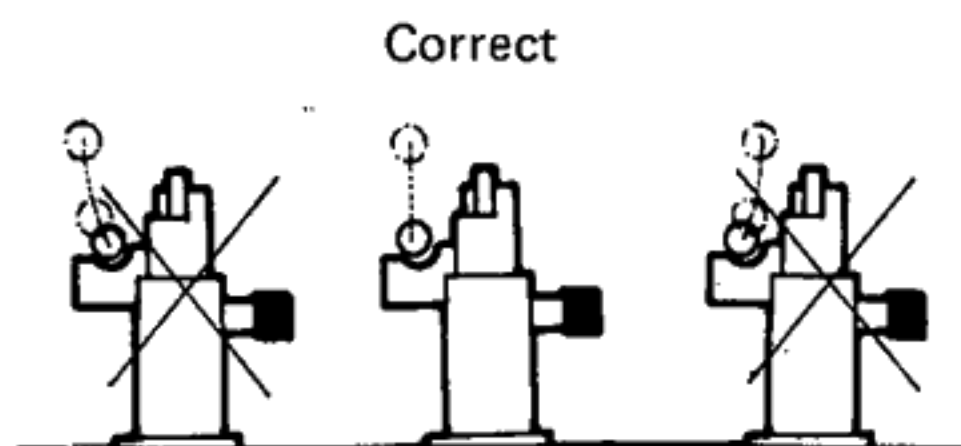

Fig. 11

- 1) Depress the ◀ (START) button to cause lead-in of the tonearm. (Watch carefully as the tonearm may fail to perform proper lead-in.)
- 2) Using a screwdriver, slightly turn the arm rest position adjustment screw.
- 3) Depress the ▶ (STOP) button to return the tonearm to the arm rest. Confirm that the tonearm descends properly without touching either the right or left side of the arm rest. If it does not descend properly into the notch, adjust its position by repeating the above adjustments.

Upon completion of adjustments, confirm proper lead-in. If the stylus fails to descend properly into the lead-in groove, re-adjust by following the instructions given in Adjustment 5. (Adjustment of Lead-in Position.)

7-1 Adjustment of Horizontal Tracking Angle

- 1) Remove the bottom cover of the turntable.
- 2) Disconnect the lead wire connected to Pin 9 of the main P.C.B. This will prevent platter rotation.
- 3) Disconnect CONN-4 (5 pin plug) from the main P.C.B.
- 4) Fig. 13 gives a detailed view of CONN-4. Push pins 3 and 5 (at Point A shown in Fig. 13) with a minus ⊖ screwdriver and remove the lead wire.

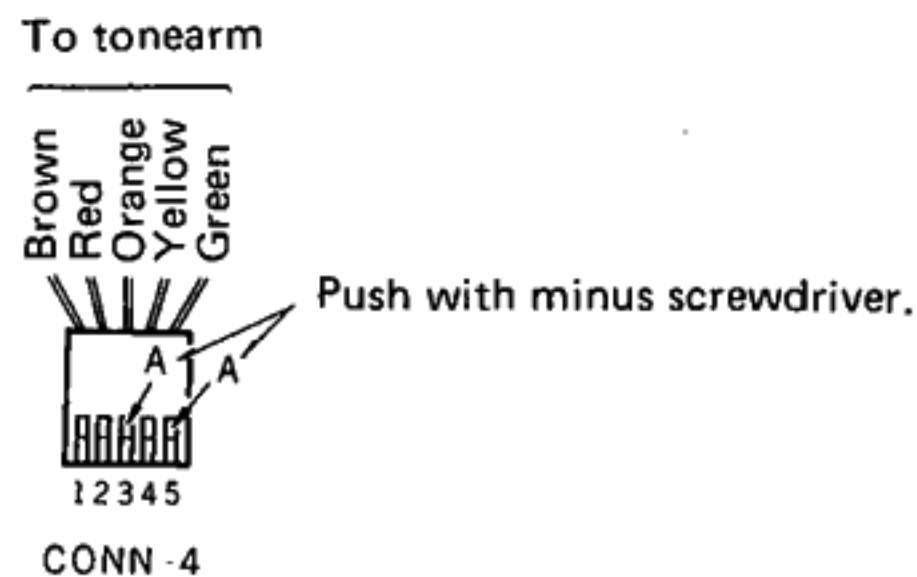

Fig. 12

- 5) Reconnect CONN-4 to the main P.C.B.
- 6) Connect the minus-side of an ammeter to pin 3 on the body-side of CONN-4, and the plus-side to the orange lead removed from CONN-4.
- 7) Connect the minus-side of the other ammeter to pin 5 on the body-side of CONN-4 and the plus-side to the green lead removed from CONN-4.

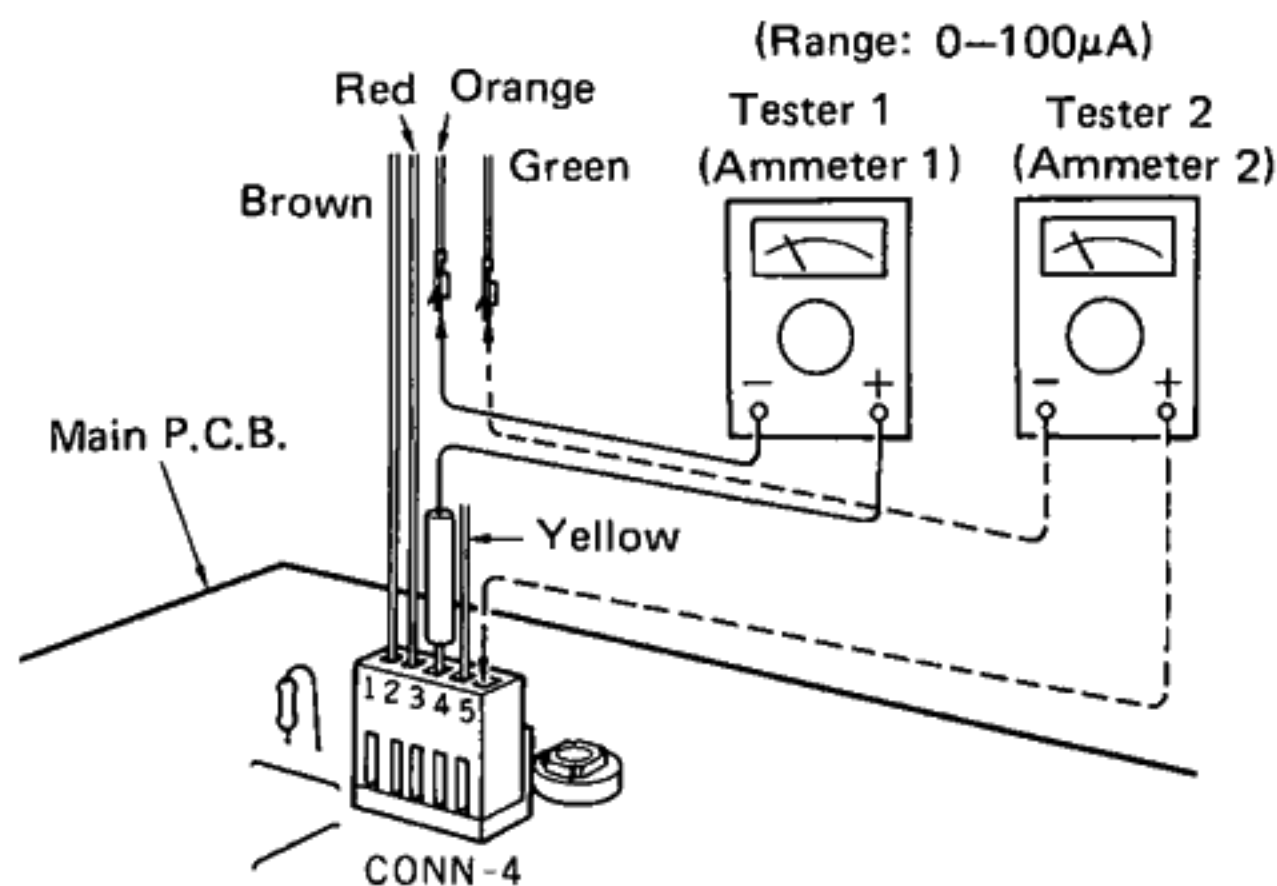

Fig. 13

- 8) After turning on the power, depress the ◀ (START) button. The tonearm will be activated and descend into the record's lead-in groove. The tonearm will not move further due to no platter rotation although the tracking servo will be turned on.
- 9) Again turn off the power switch.
- 10) Disengage the drive belt for the horizontal drive motor.
- 11) Position the tonearm so the space "A" and "B" are equal to each other as shown in Fig. 14 below.

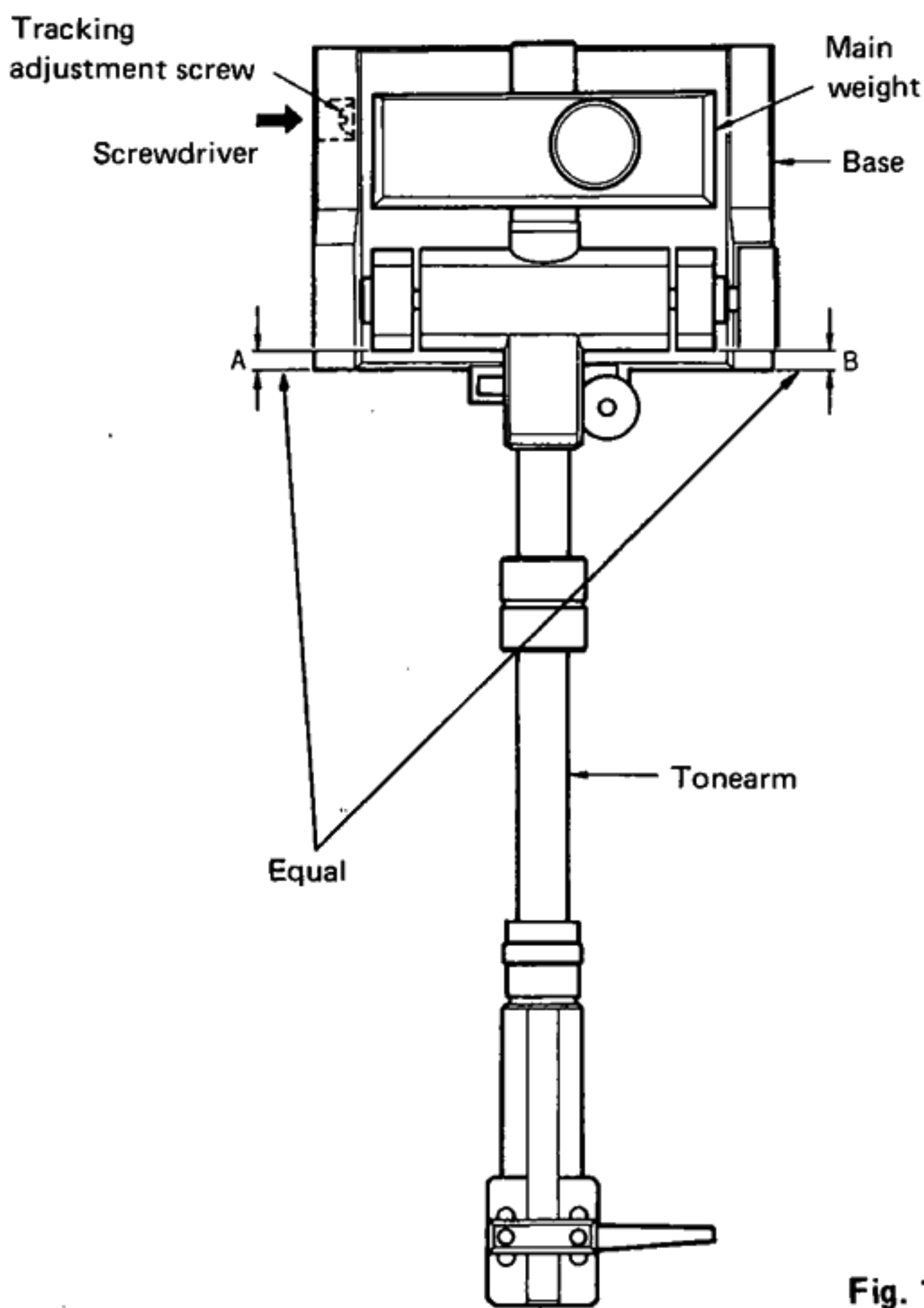

Fig. 14

- 12) Read the current indicated on both the ammeters connected in steps 6) and 7).
- 13) If the two current indications are not equal adjust the Tracking Adjustment screw. When these two measurements are equal they should be in the range of 8 to $20\mu\text{A}$.
- 14) Disconnect the ammeters and reinsert the lead wires to CONN-4. Reconnect CONN-4 to the main P.C.B.

7-2 Adjustment of Tracking Servo Amplifier

- 1) The tracking servo amplifier gain is to be adjusted only after adjustment 7-1) has been completed.
- 2) Connect a DC voltmeter between Pin 12 of the main P.C.B. and ground (Pin 10). Adjust VR101 for a reading of 5.5 volts. Then with the voltmeter connected between Pin 13 and ground adjust VR102 for 5.5 volts on the voltmeter.
- 3) After completing the adjustments apply lock-tight to the semi-fixed resistors.
- 4) Reconnect the lead wire to Pin 9 to restore platter operation. Re-engage the drive belt to restore horizontal drive motor operation.

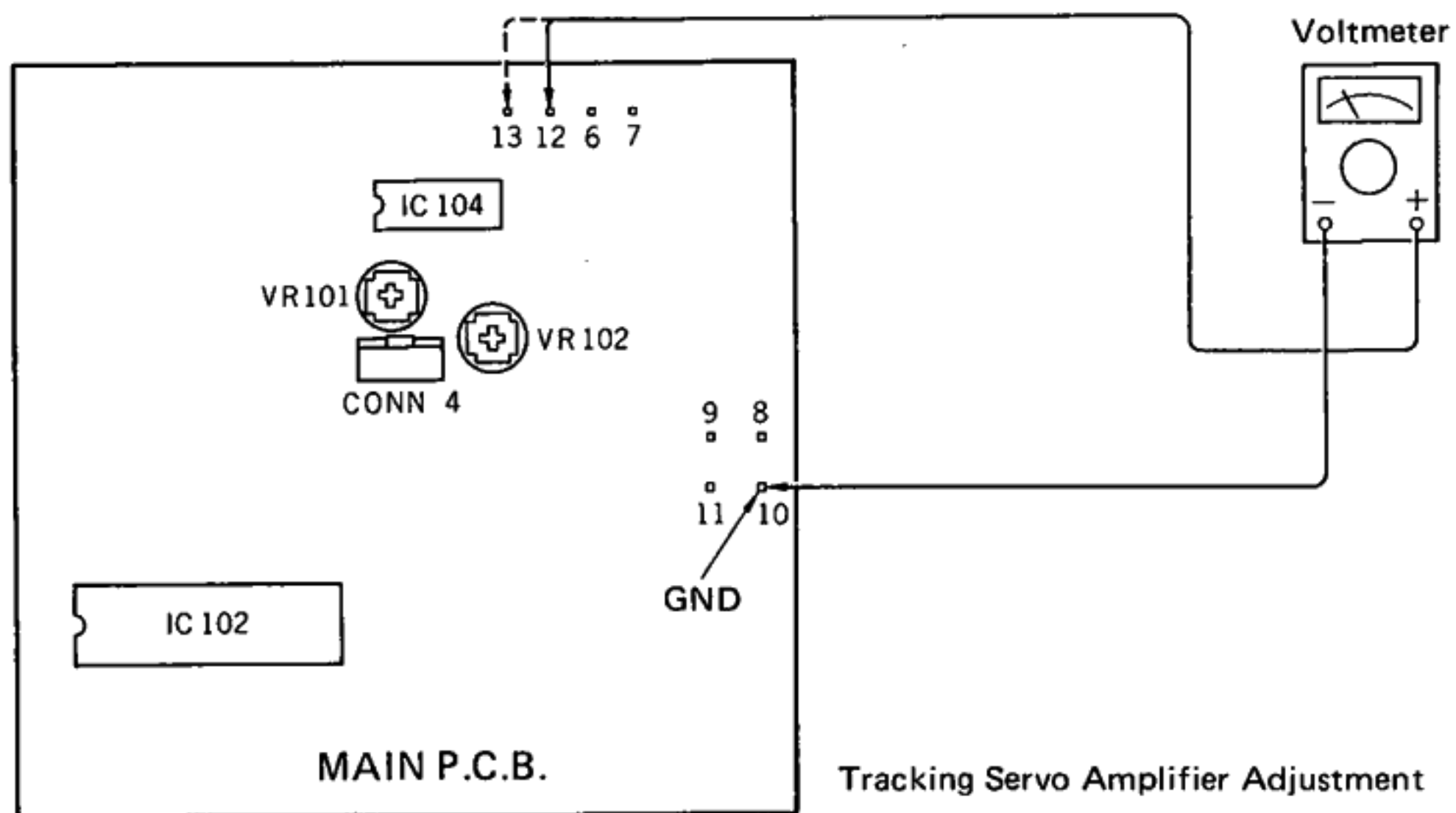
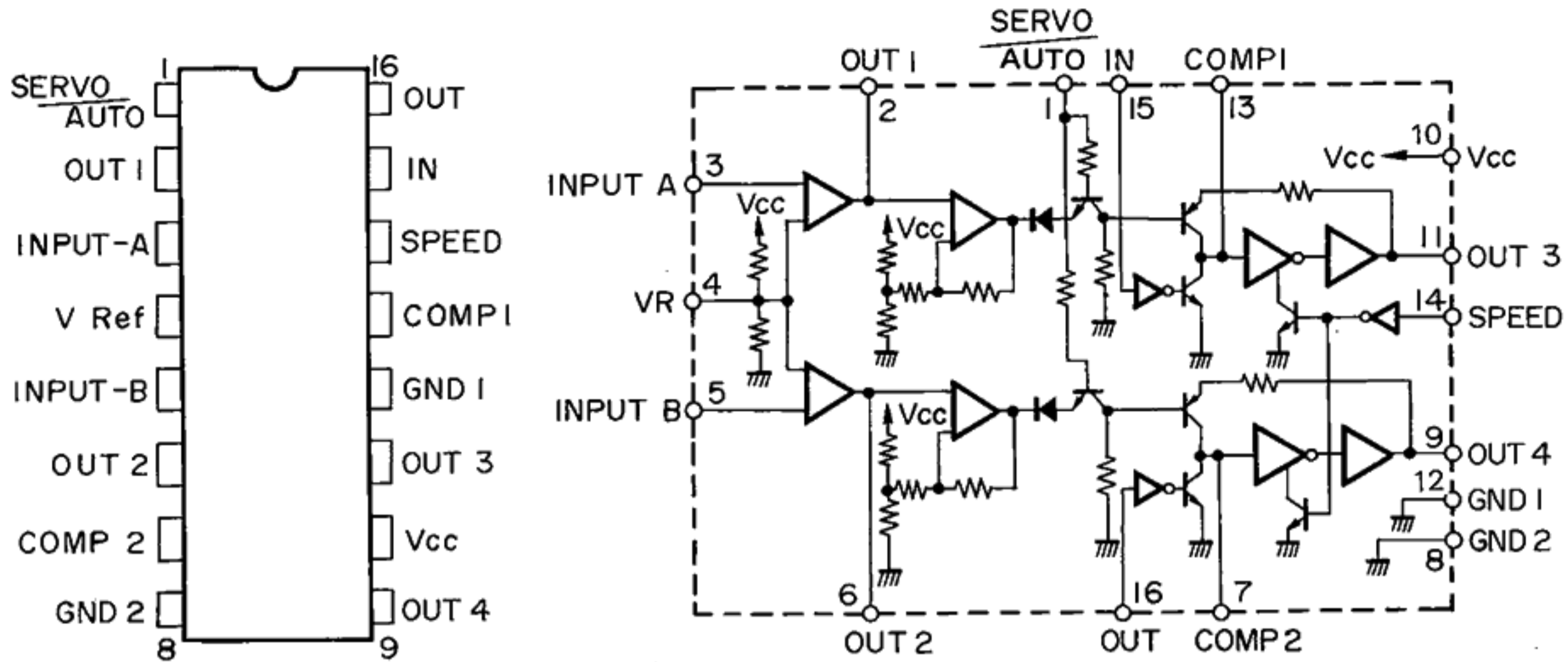

Fig. 15

INTERNAL DIAGRAMS AND PINOUT OF INTEGRATED CIRCUITS:

MSA117RS HORIZONTAL DRIVE I.C.



TC4011BP

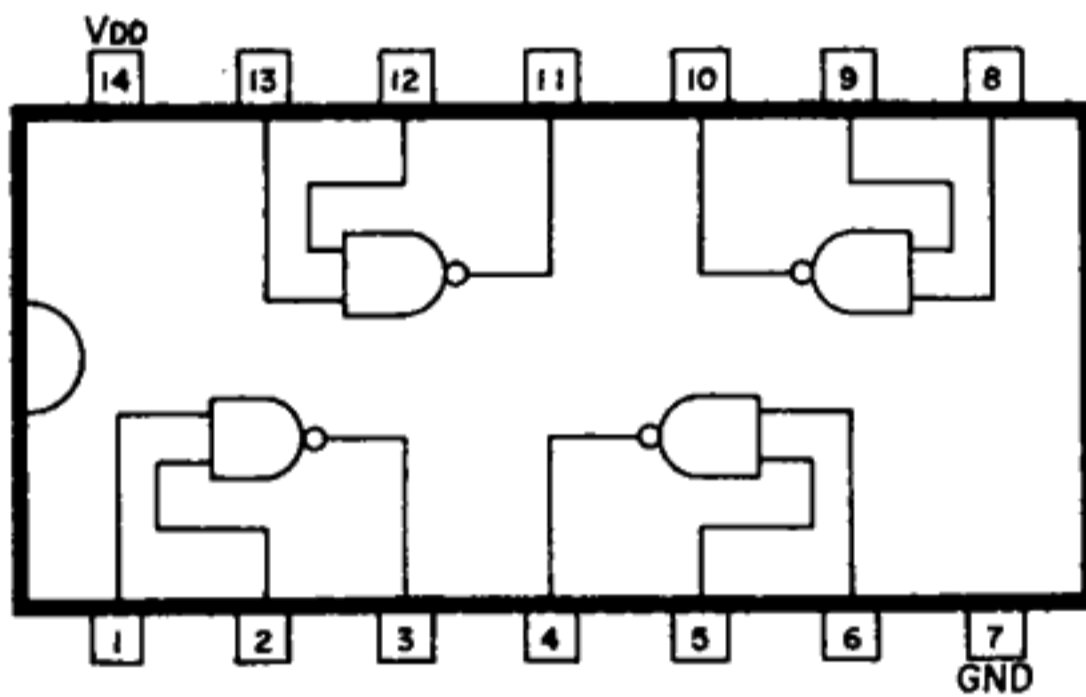

TC9142P

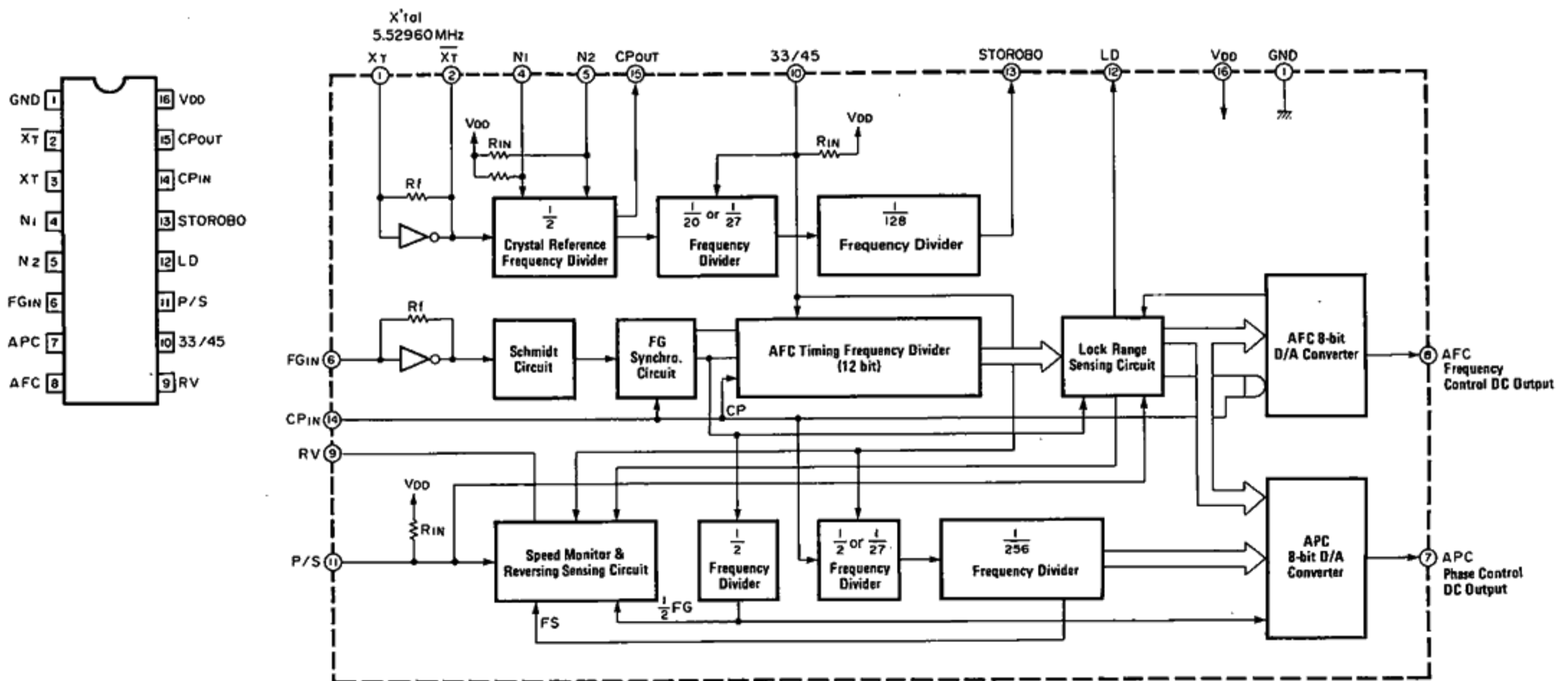

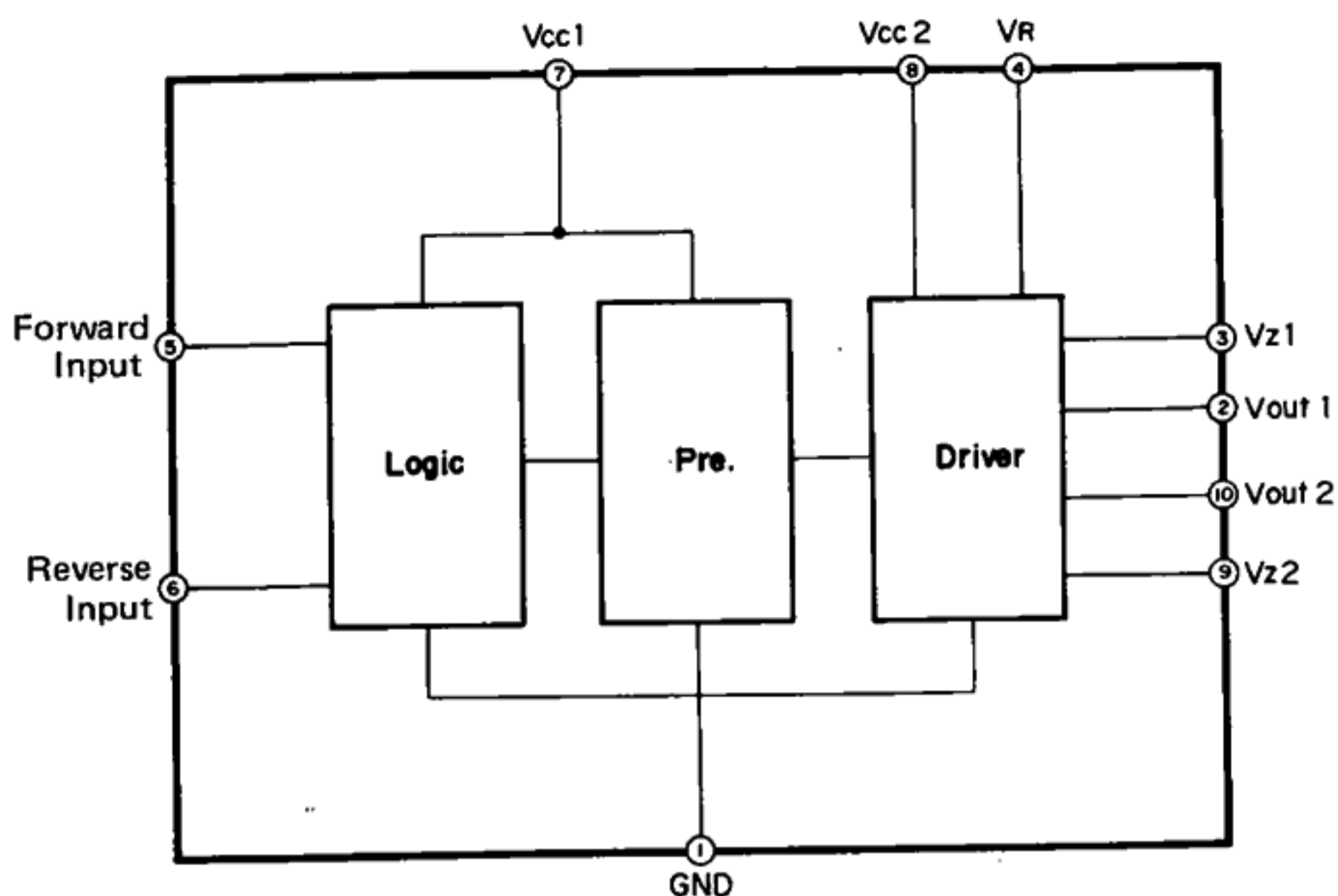

INPUT/OUTPUT TRUTH TABLE

F IN	R IN	Vout1	Vout2
H	H	L	L
L	H	L	H
H	L	H	L
L	L	OPEN	OPEN

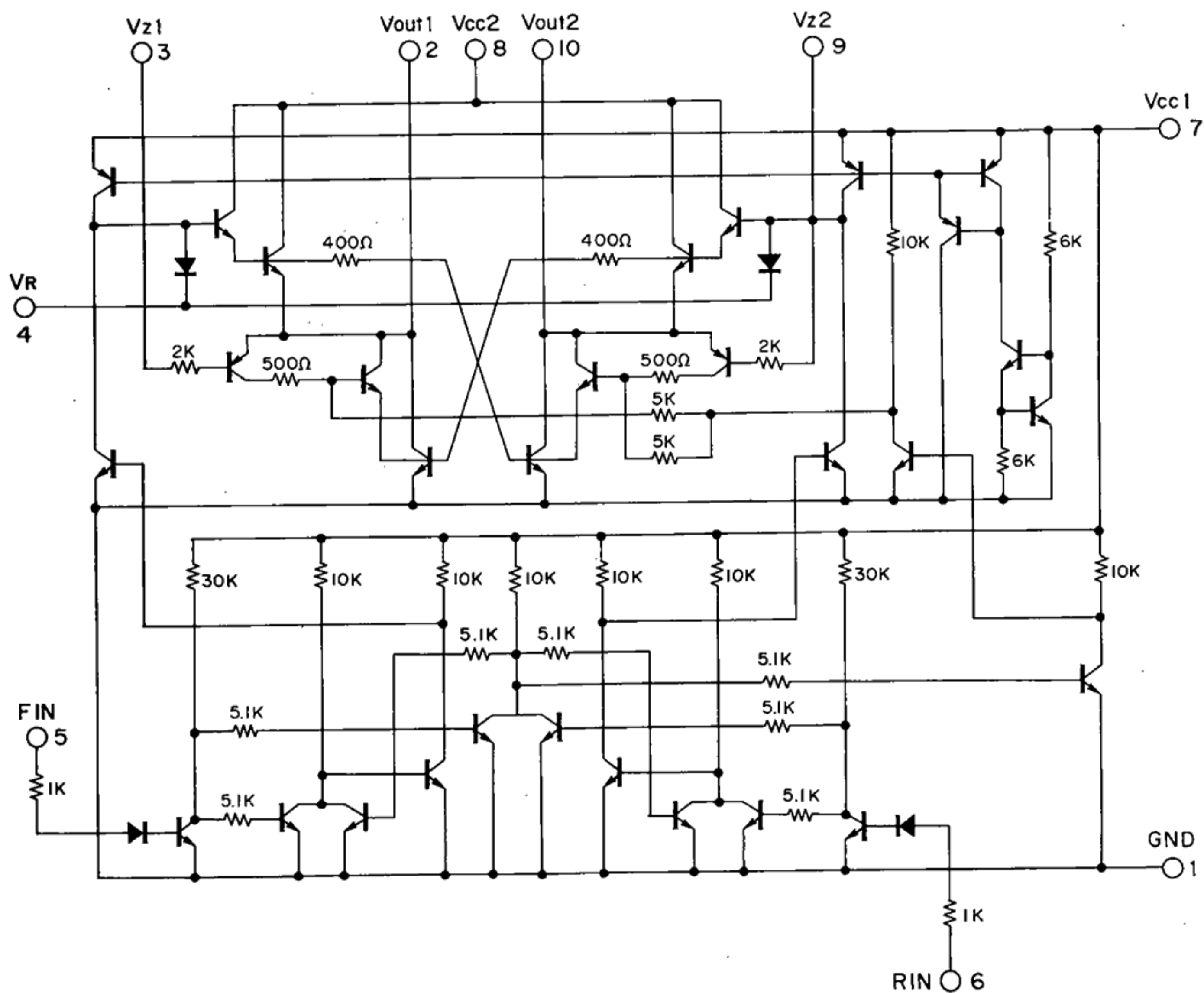

INFORMATION ON LOGIC IC (MSM-5831RS)

1. Circuit Construction

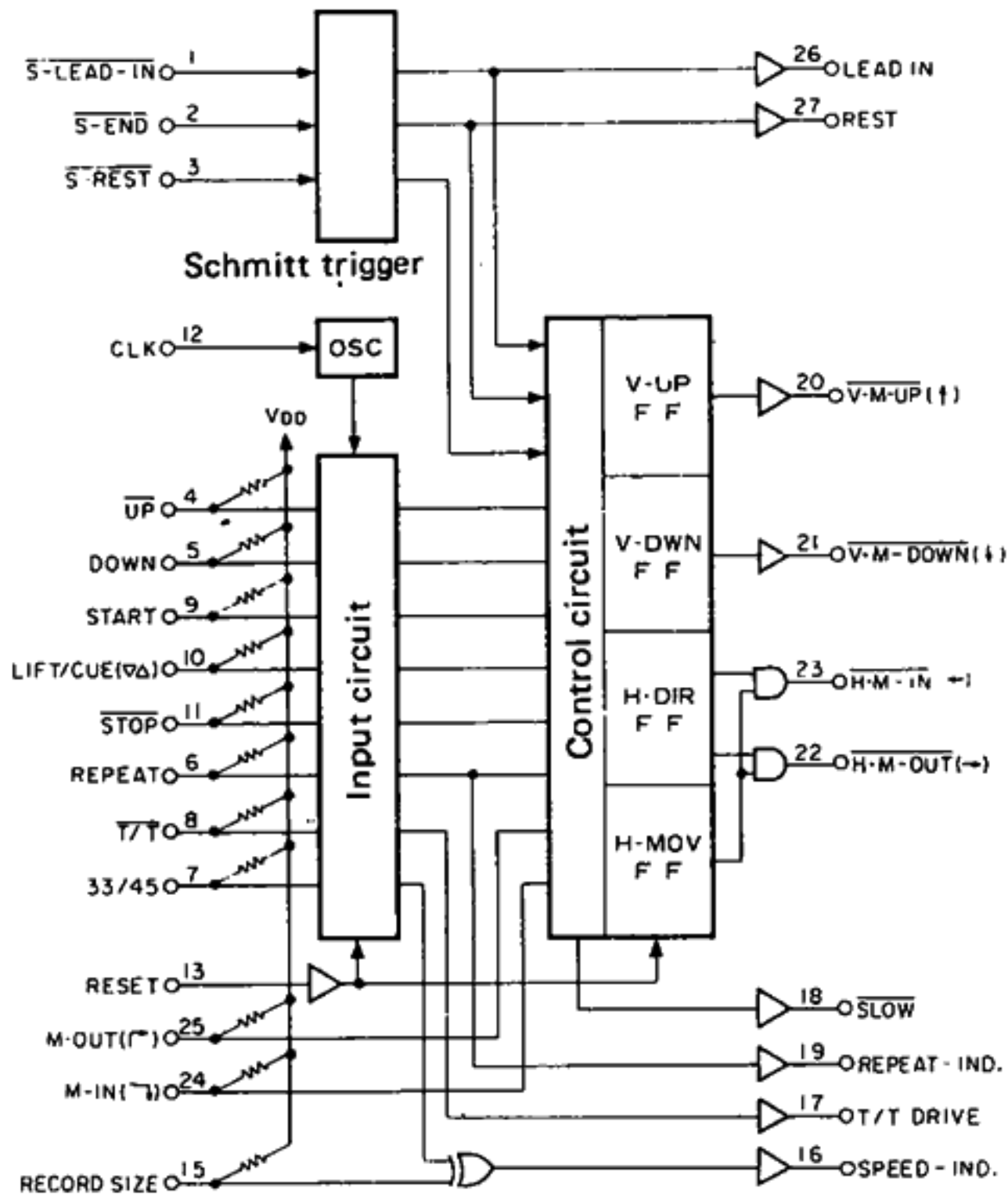

2. Pin and Function

1 (S-LEAD-IN):

L when tonearm is on a record, otherwise H.

2 (S-END):

Becomes L when tonearm is moving inwards on a record and reaches the end groove, otherwise H.

3 (S-REST):

L when at arm rest, otherwise H.

4 (\overline{UP}):

L when tonearm is being lifted or moving horizontally, otherwise H.

5 (DOWN):

L when tonearm is at arm rest or on a record, otherwise H.

6 (REPEAT):

Ordinarily H. When L is fed into this pin, the tonearm continues the repeat operation. To release, feed in L once more or make 11 (STOP) L.

7 (33/45):

Used when selecting platter speed manually. Making this pin L causes speed to change from 33-1/3 rpm to 45 rpm or vice versa.

9 (START), 10 (LIFT/CUE), 11 (\overline{STOP}):

When START becomes L, the tonearm moves inwards; when STOP becomes L, the tonearm moves outwards. When LIFT/CUE becomes L, the tonearm is lifted or lowered. Note that, while the tonearm is being lifted, making this pin L produces no change, but if L is fed in during the lowering process, it changes back to upwards.

12 (CLK):

By connecting an external resistor/condensor combination to the input, a reference clock pulse is generated internally.

13 (RESET):

A resistor/condensor combination is connected to the input. Immediately after switching on the power, the RESET input becomes L, blocking automatic movement of the tonearm.

14 (Vss):

Connects to ground.

15 (RECORD SIZE):

L indicates 30 cm LP, H indicates 17 cm EP.

16 (SPEED-IND):

L indicates 33-1/3 rpm, H indicates 45 rpm. Can be changed freely by making 7 (33/45) L.

17 (T/T-DRIVE):

When 9 (START) becomes L, this pin becomes H and the platter rotates. When record play is finished and the returns to arm rest position, this pin becomes L and platter rotation stops.

18 (SLOW):

To move the tonearm horizontally while on a record, this output becomes L and the horizontal motion speed is low. At H level, the motion speed is high.

19 (REPEAT-IND):

When 6 (REPEAT) is L in the repeat mode, this pin becomes L.

20 ($\overline{V.M-UP}$), 21 ($\overline{V.M-DOWN}$), 22 ($\overline{H.M-OUT}$), 23 ($\overline{H.M-IN}$):

When the tonearm is at rest position or on a record and thus 5 (DOWN) is L, at first 20 ($\overline{V.M-UP}$) becomes L and the tonearm moves up, causing 5 (DOWN) to become H. At that time 4 (\overline{UP}) is L, and when the tonearm stops at the upper limit, the horizontal motion starts. When the tonearm moves inwards, 23 ($\overline{H.M-IN}$) is L, when it moves outwards, 22 ($\overline{H.M-OUT}$) is L. When the tonearm has moved to the pre-set horizontal position and is being lowered, 21 ($\overline{V.M-DOWN}$) becomes L. Thus, of these 4 signals during tonearm movement, there is always one which becomes L, but never two or more simultaneously.

27 (REST):

Same as output of 3 ($\overline{S-REST}$).

28 (Vpp):

Supply voltage INPUT.

WIRING DIAGRAM:

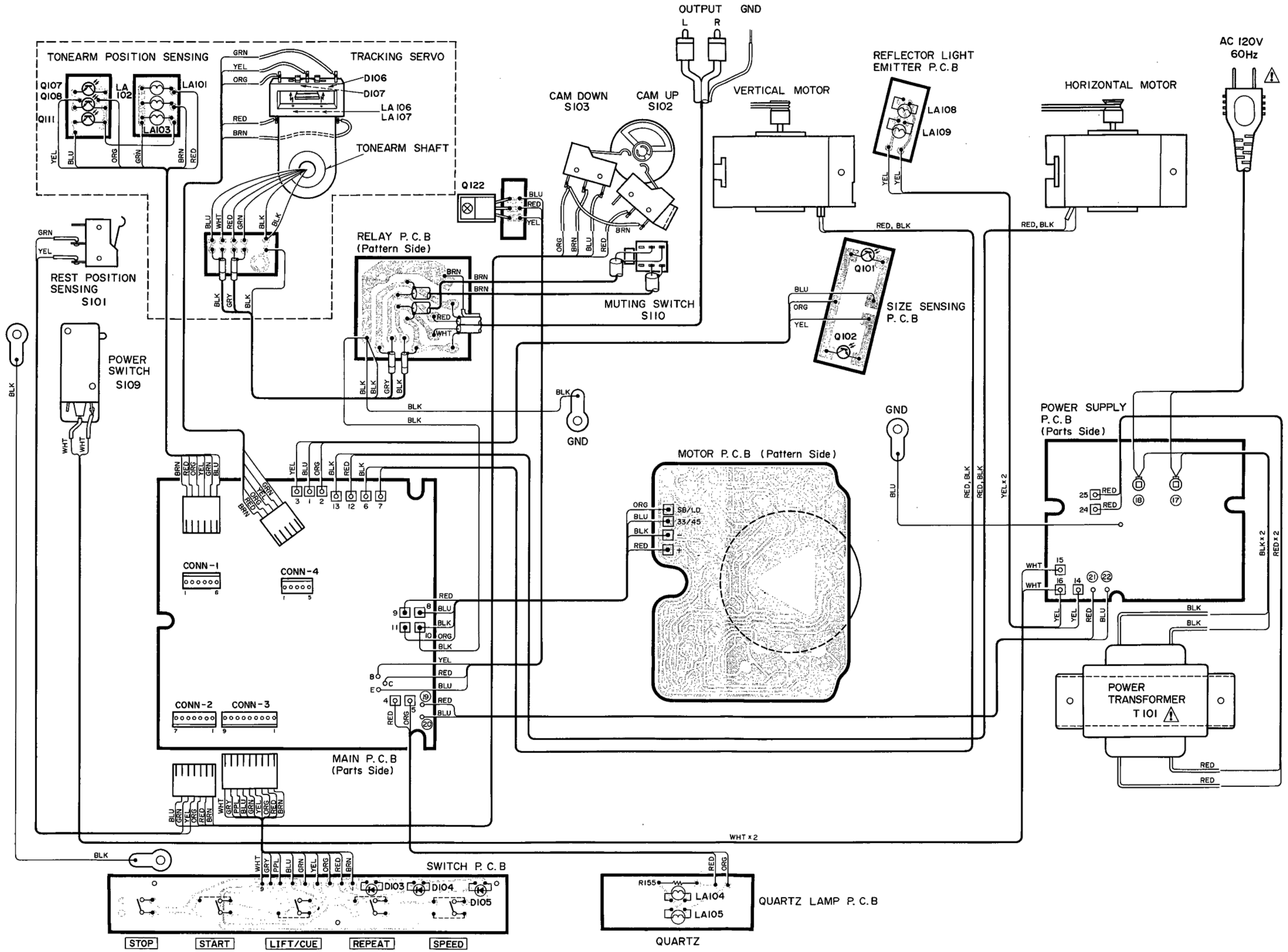

PRINTED CIRCUIT BOARDS

MAIN P.C BOARD

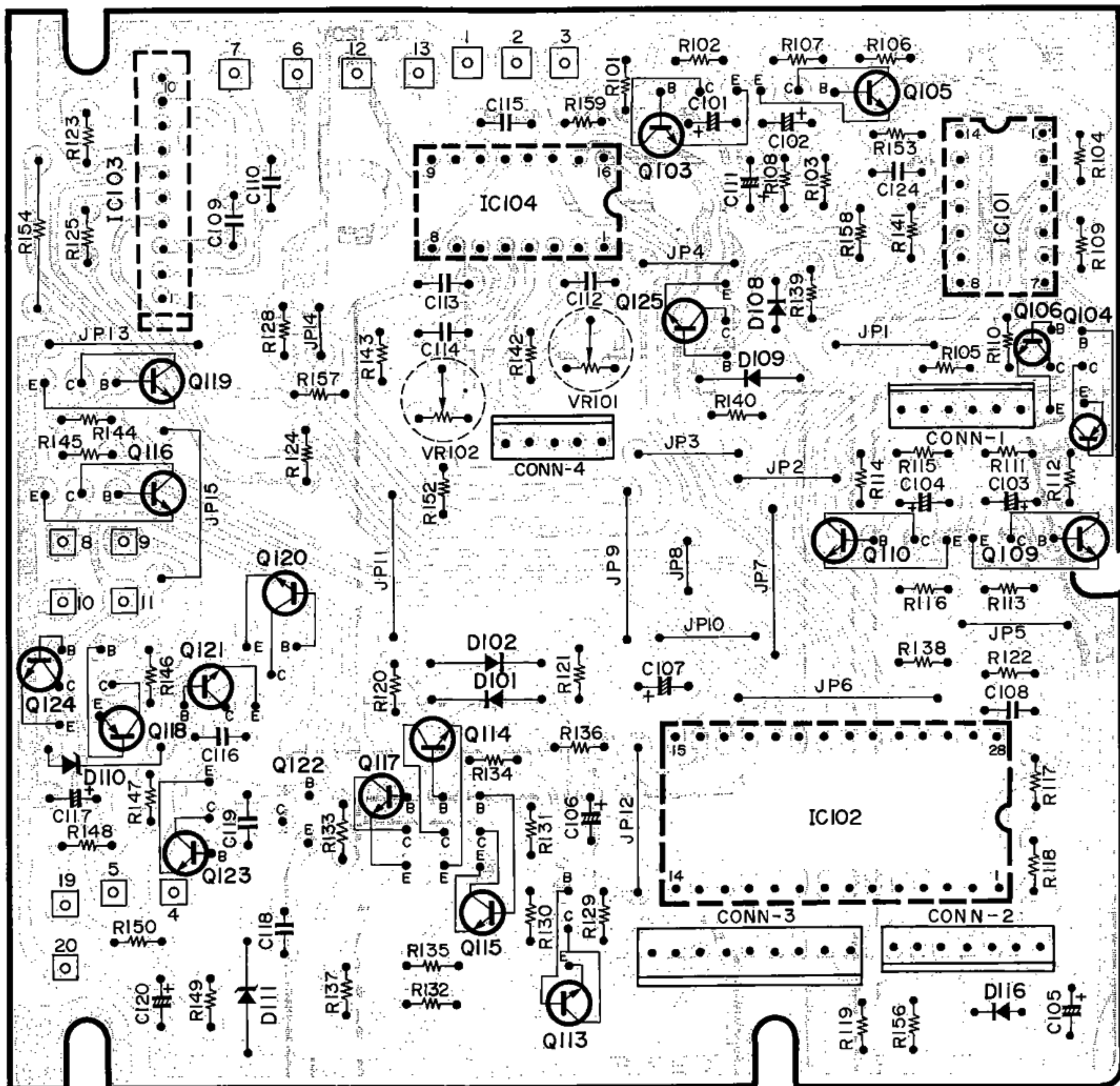

DD MOTOR P.C BOARD

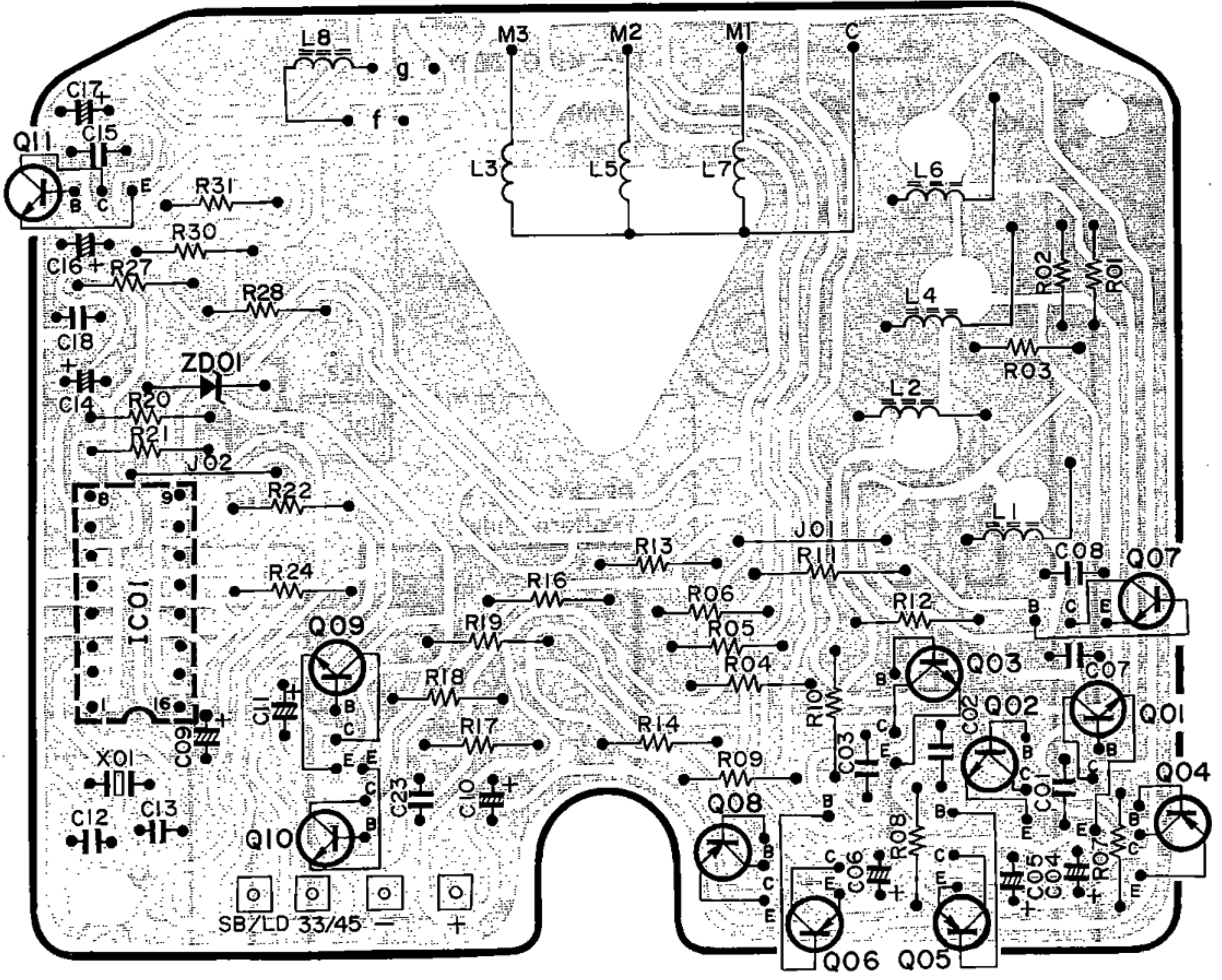

POWER SUPPLY P.C BOARD

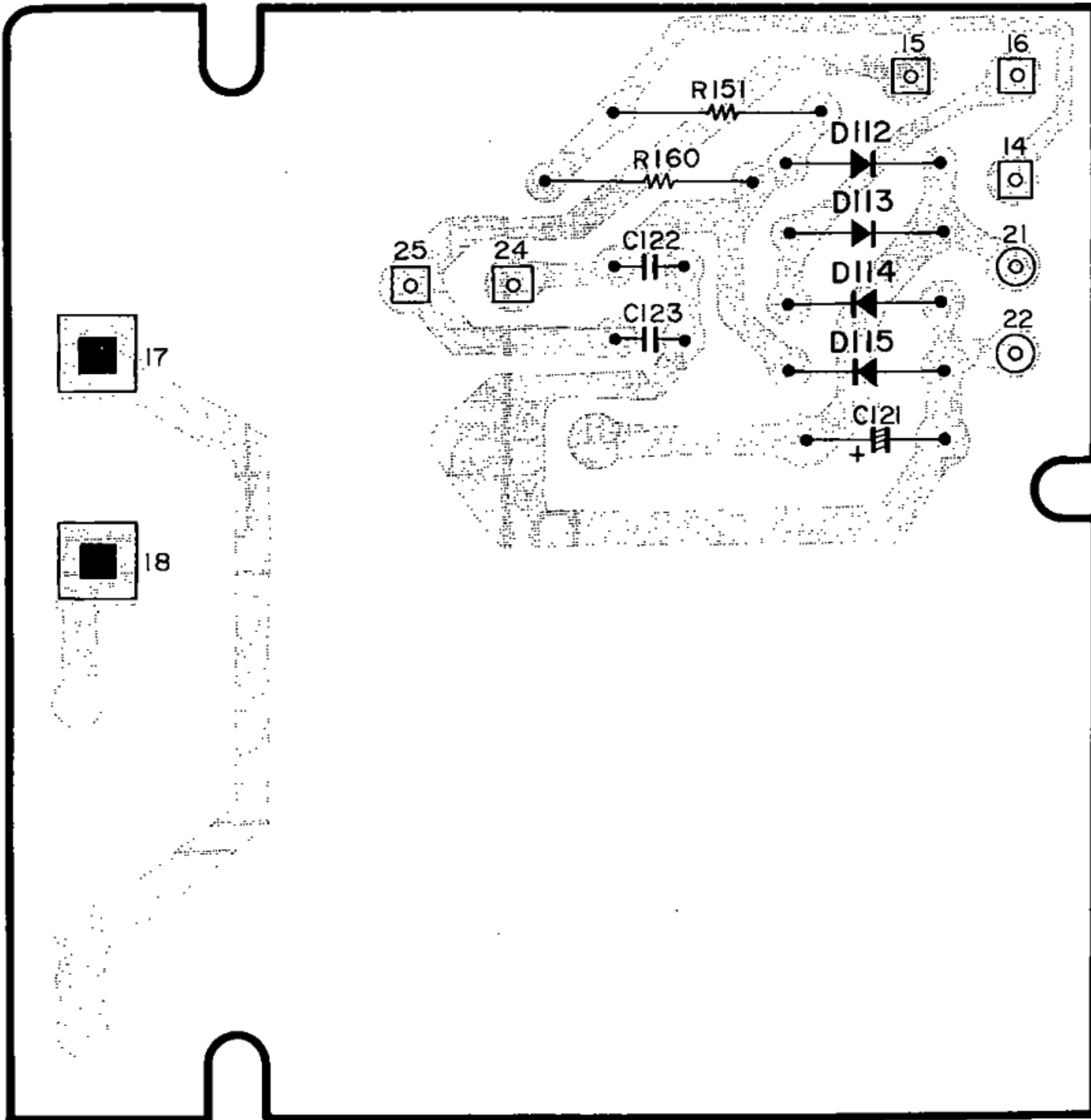

SCHEMATIC DIAGRAM:

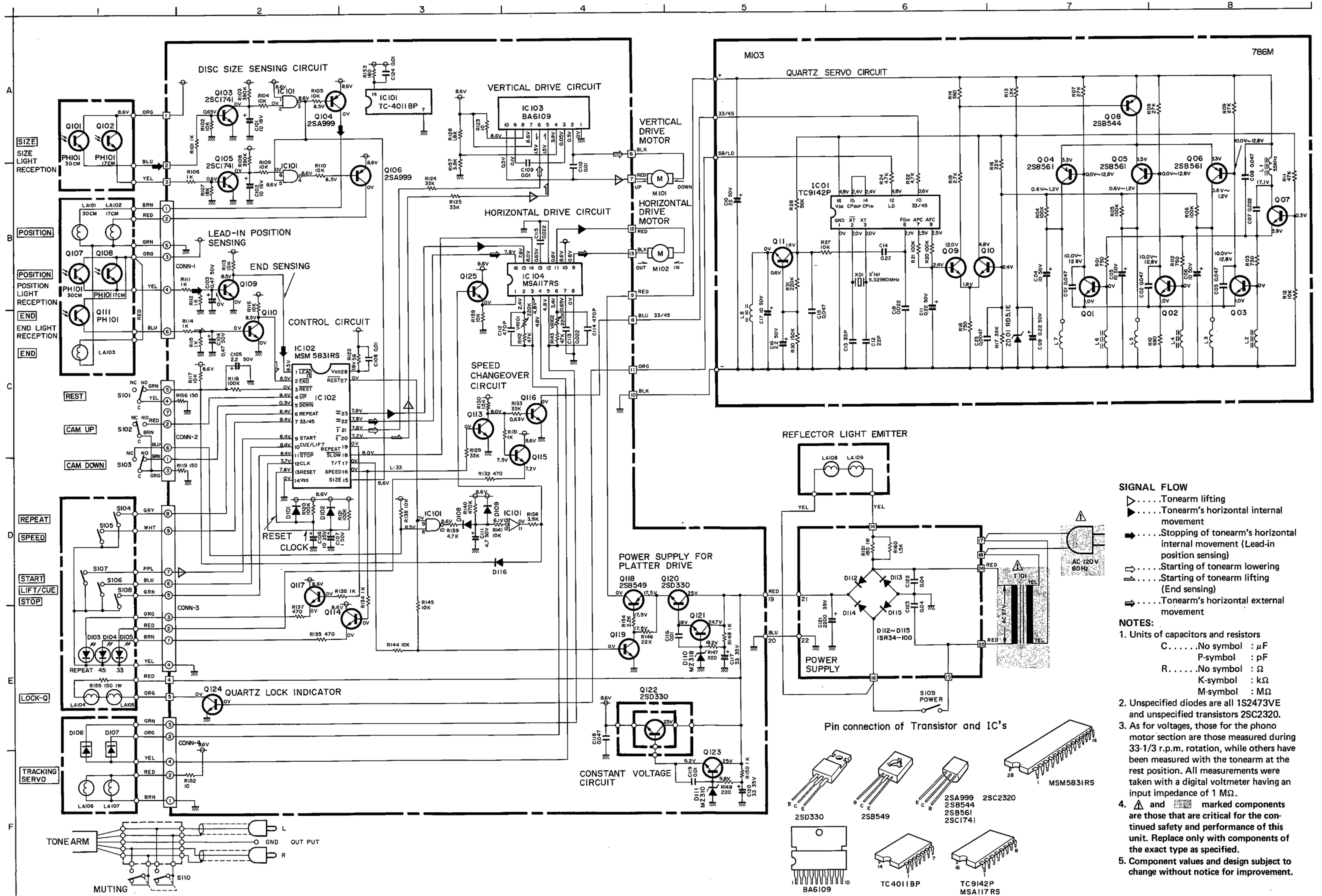

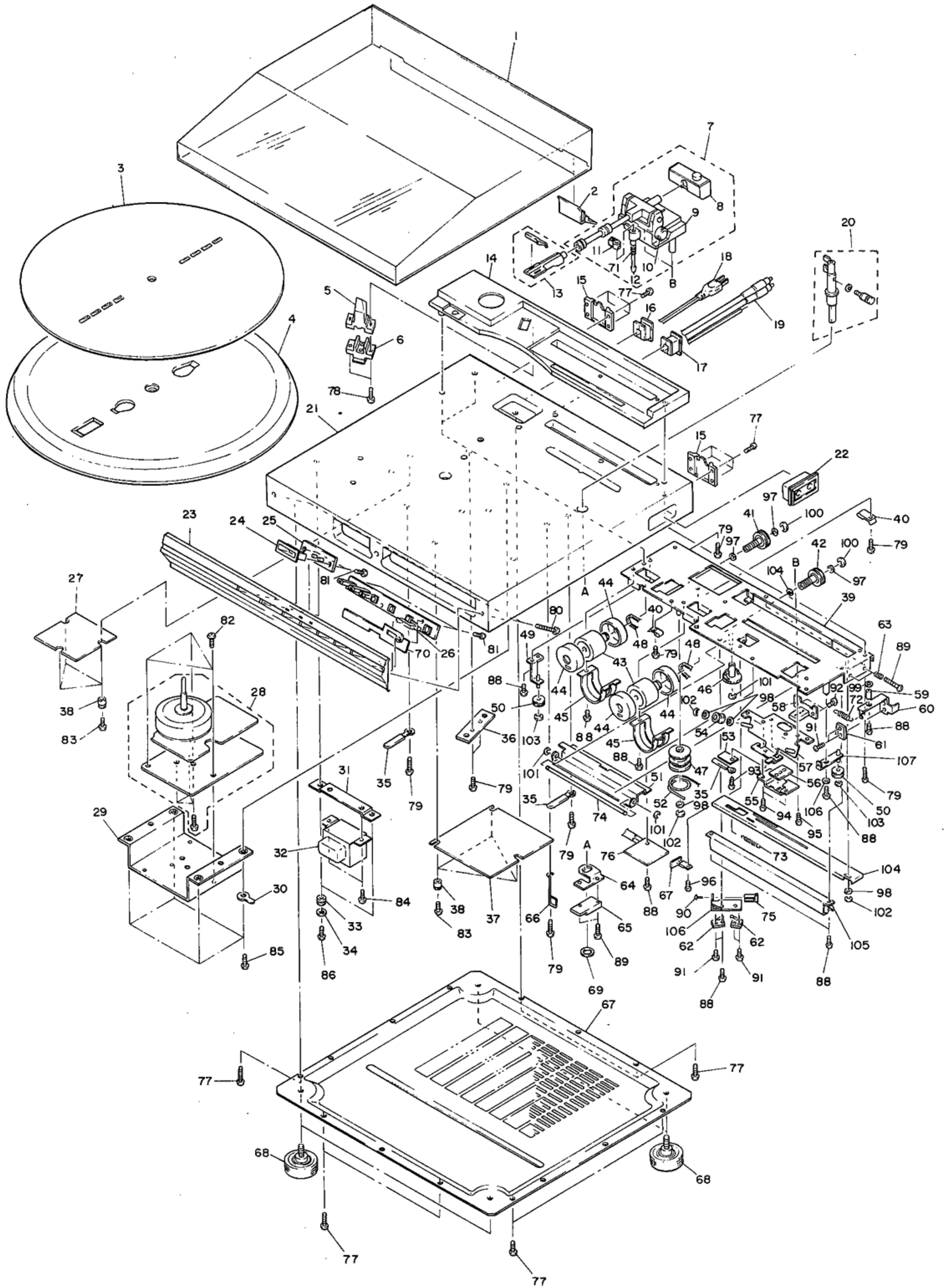

EXPLODED VIEW:





PARTS LIST:

Symbol No.	Parts No.	Description
1	M07527690	Dust Cover
2	M07527127	Hinge
3	M07543622	Platter Sheet-Assy
4	M07543620	Platter
5	M07137605	Refelector (Emitter)
6		Holder
7	M07543600	Tonearm-Assy (with weight-assy)
8	M07527635	Weight-Assy
9		Base
10		Knob
11	M07527753	Arm Lifter
12		Shaft
13	M07543616	Head Shell-Assy
14	M07543225	Ornament
15		Hinge-Holder
16	M07527445	Clamper
17	M07527446	Clamper
18	M07461440	Power Cord
19	M07527446	Output Cord
20	M07527618	Arm Rest-Assy
21		Cabinet
22		Cover
23	M07543100	Panel-Assy
24		Holder
25		PCB-Assy
26	M07527210	Knob
27		PCB-Assy
28	M07543550	Motor (786M)
29		Holder
30		Terminal
31		Holder
32	M07543500	Power Transformer
33		Gum-Bush
34		Washer
35		Clamper
36		PCB-Assy
37		PCB-Assy (Logic)
38		Metal Coller
39		Base
40		Clamper
41	M04165646	Gear (Vertical)
42	M07527645	Gear (Horizontal)
43	M07469639	Motor
44		Cover
45		Holder
46	M07527646	Gear (UP-DOWN)
47	M04165621	Gear (Horizontal-Big)
48	M04162628	Belt
49		Holder
50		Pulley
51		Holder
52	M07543670	Wire
53		Cover
54		Pulley
55		Holder
56		PCB-Assy
57		Holder
58		Holder
59		Metal Coller
60		Holder
61	M04165459	Switch-Micro (Rest)
62	M07297450	Switch-Micro (CAM UP, DOWN)

Symbol No.	Parts No.	Description
63		Spring
64		Holder
65	M07179660	Switch-Micro (POWER)
66		Clamper
67		Cover-Bottom
68	M07550190	Leg
69		Nut M14
70		Shield-Plate
71		Spring
72		Spring
73		Spring
74		Shaft
75		Holder
76		P.C.B.-Ass'y
77		Tapping-Screw 1 - 3 x 14
78		Screw-Metal M3 x 16
79		Tapping-Screw 1 - 3 x 12
80		Tapping-Screw 1 - 3 x 20
81		Tapping-Screw 1 - 3 x 10
82		Screw-Metal M3 x 6
83		Tapping-Screw 1 - 3 x 20
84		Screw-Bind M4 x 5
85		Tapping-Screw 1 - 4 x 14
86		Tapping-Screw 1 - 3 x 25
87		
88		Screw-Metal M3 x 8
89		Screw-Bind M3 x 16
90		Screw-Bind M2.6 x 5
91		Screw-Bind M2 x 8
92		Screw-Bind M3 x 5
93		Screw-Bind M3 x 8
94		Screw-Bind M3 x 4
95		Screw-Bind M4 x 6
96		Screw-PC M3 x 6
97		Washer 2 Φ
98		Washer 2.4 Φ
99		Washer 3 Φ
100		E-ring 2
101		E-ring 3
102		E-ring 2.4
103		E-ring 1.5
104		Shade-Plate
105		Holder
106		Holder
107		Holder

NOTE:  and  marks components which have special characteristics to maintain the safety performance of this unit. When replacing any of these parts, be sure to use only the specified parts.

Symbol No.	Parts No.	Description
Diodes		
D101	M07060320	1S2473VE
D102	M07060320	1S2473VE
D103	M07543325	SR535D
D104	M07543326	SG235D
D105	M07543326	SG235D
D106	M07297320	SP254FS
D107	M07297320	SP254FS
D108	M07060320	1S2473VE
D109	M07060320	1S2473VE
D110	M07151322	MZ318
D111	M07171322	MZ310
D112	M07391320	1SR34-100
D113	M07391320	1SR34-100
D114	M07391320	1SR34-100
D115	M07391320	1SR34-100
D116	M07060320	1S2473VE
ZD 01	M07452323	5.1E3
ICs		
IC101	M07297343	TC4011BP
IC102	M07437343	MSM-5831RS
IC103	M07527343	BA6109
IC104	M07527344	MSA117RS
IC 01	M07508310	TC9142P
Transistors		
Q101	M07137303	PH101
Q102	M07137303	PH101
Q103	M07137307	2SC1741
Q104	M07390304	2SA999
Q105	M07137307	2SC1741
Q106	M07390304	2SA999
Q107	M07137303	PH101
Q108	M07137303	PH101
Q109	M07390303	2SC2320
Q110	M07390303	2SC2320
Q111	M07137303	PH101
Q113	M07390303	2SC2320
Q114	M07390303	2SC2320
Q115	M07390303	2SC2320
Q116	M07390303	2SC2320
Q117	M07390303	2SC2320
Q118	M07230307	2SB549
Q119	M07390303	2SC2320
Q120	M07061304	2SD330
Q121	M07390303	2SC2320
Q122	M07061304	2SD330
Q123	M07390303	2SC2320
Q124	M07390303	2SC2320
Q125	M07390303	2SC2320

Symbol No.	Parts No.	Description
Q 01	M07390303	2SC2320
Q 02	M07390303	2SC2320
Q 03	M07390303	2SC2320
Q 04	M07215304	2SB561
Q 05	M07215304	2SB561
Q 06	M07215304	2SB561
Q 07	M07390303	2SC2320
Q 08	M07508308	2SB544
Q 09	M07390303	2SC2320
Q 10	M07390303	2SC2320
Q 11	M07390303	2SC2320
Electrical Parts		
LA101	M07374251	Lamp 12V 0.05A (Position)
LA102	M07374251	Lamp 12V 0.05A (Position)
LA103	M07374251	Lamp 12V 0.05A (END)
LA104	M07374251	Lamp 12V 0.05A (Lock)
LA105	M07374251	Lamp 12V 0.05A (Lock)
LA106	M07374251	Lamp 12V 0.05A (Tracking)
LA107	M07374251	Lamp 12V 0.05A (Tracking)
LA108	M07297250	Lamp 5V 0.06A (Reflector)
LA109	M07297250	Lamp 5V 0.06A (Reflector)
S101	M04165459	Micro Switch (REST)
S102	M07297450	Micro Switch (CAM UP)
S103	M07297450	Micro Switch (CAM DOWN)
S104	M07445660	Push Switch (REPEAT)
S105	M07445660	Push Switch (SPEED)
S106	M07445660	Push Switch (START)
S107	M07445660	Push Switch (LIFT/CUE)
S108	M07445660	Push Switch (STOP)
S109	M07179660	Micro Switch (POWER)
S110	M07445661	Slide Switch (MUTING)
T101	M07543500 M07461440	Power Transformer  Power Cord 
VR101	M07543410	Semi Fixed (B220K)
VR102	M07543410	Semi Fixed (B220K)
Packing		
201	M07543900	Packing Box
202	M07527910	Cushion Mold
203	M07543910	Cushion (DUST COVER)
204	M07527930	Packing Bag
205	M07527778	Screw-Metal M3 x 30
206	M04165726	Shade (EP)
207	M04165725	Shade (LP)
	M07543940	Instruction Booklet
	M07543945	Warranty Card
	M07191603	Adaptor 45 rpm
	M07462012	Stylus Gauge
	M07297013	H-Wrench

PACKING INSTRUCTIONS:

Securing of transformer for transport

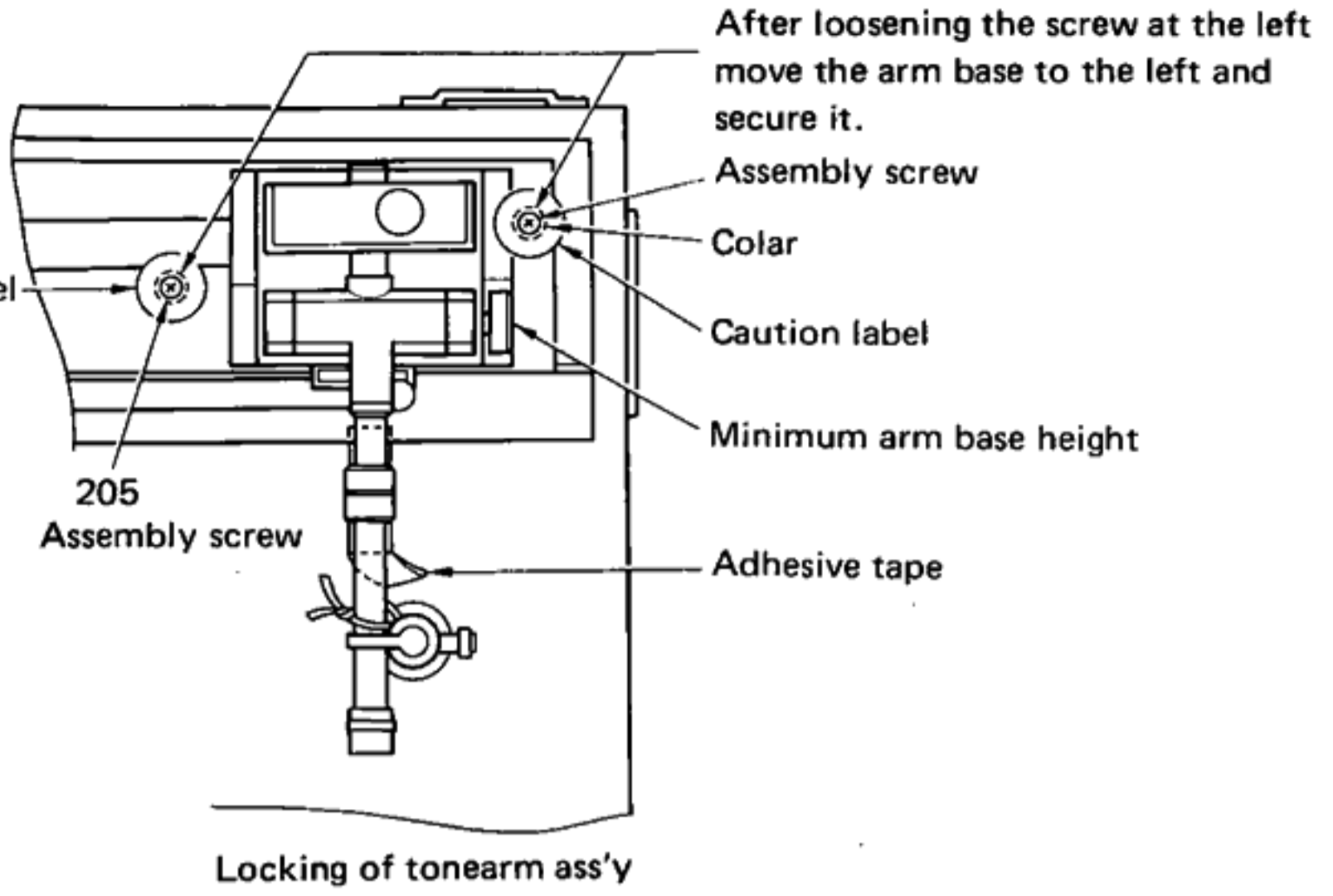
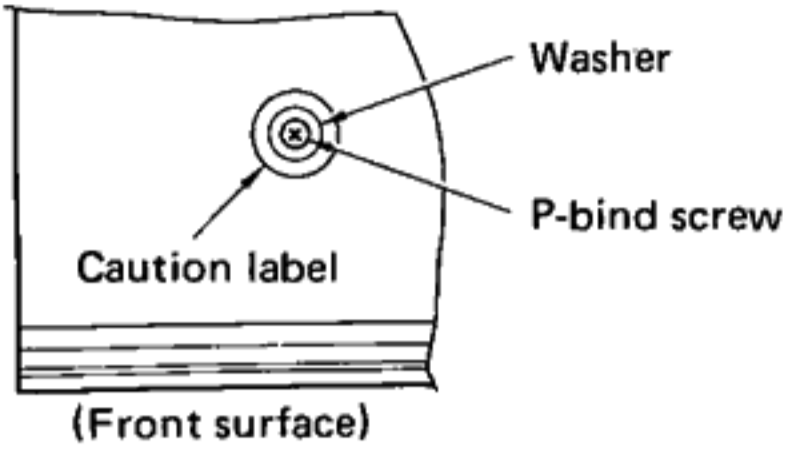

Fold and fit on top of both sides of dust cover.

