

10.6 A 715G7350 PSU
10-6-1 AC input

A01

AC input

A01

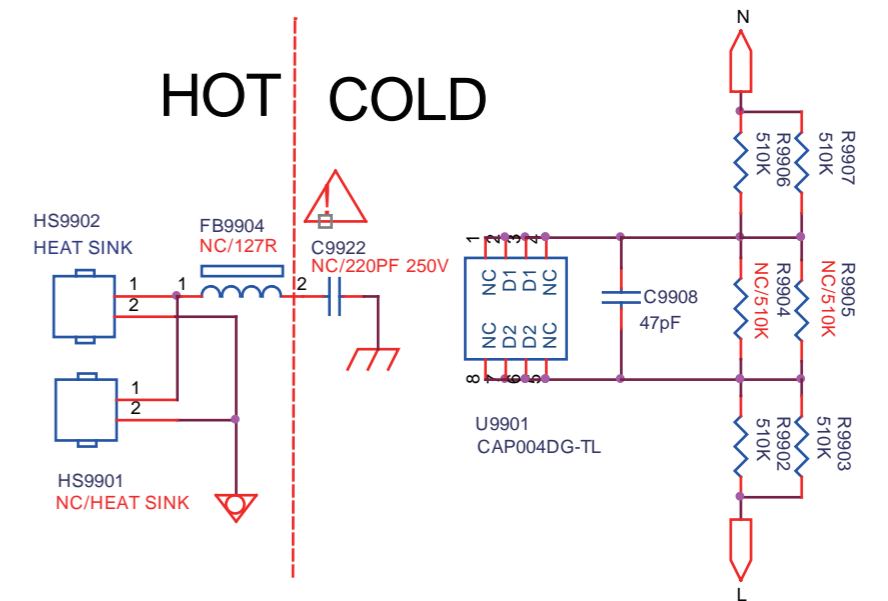
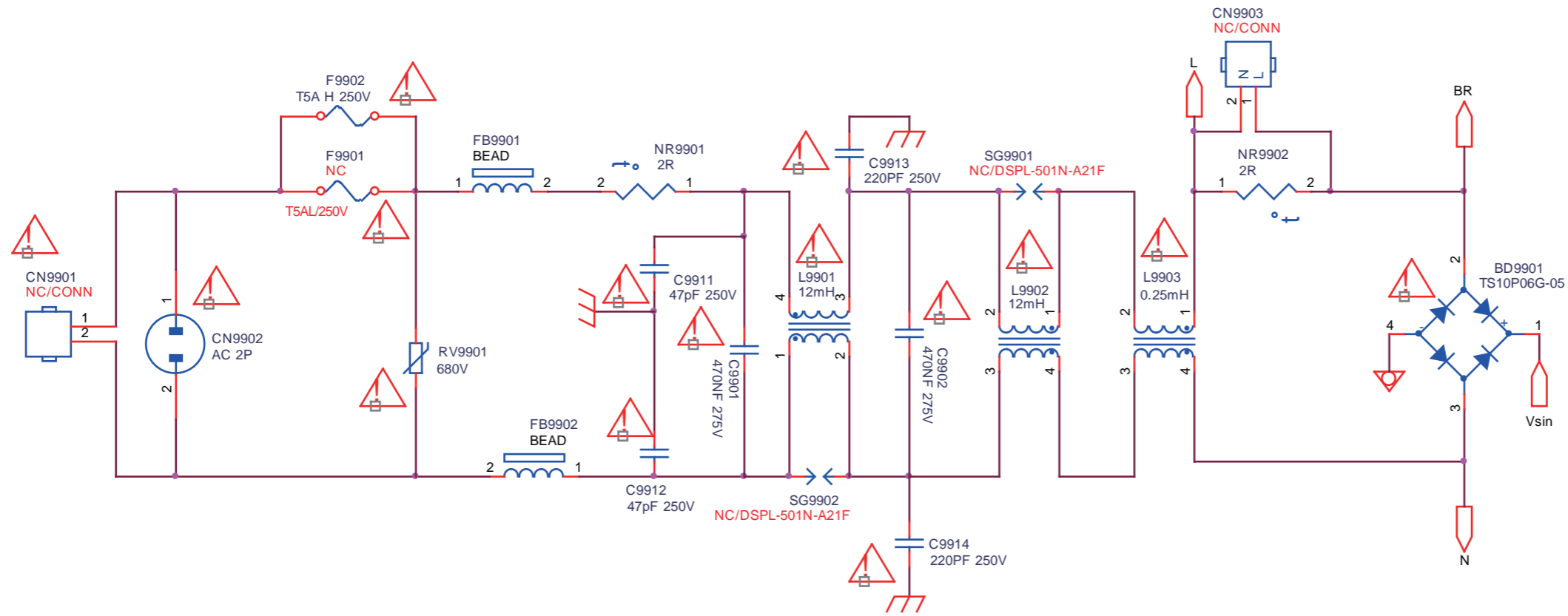

AC input

715G7350

2016-11-16

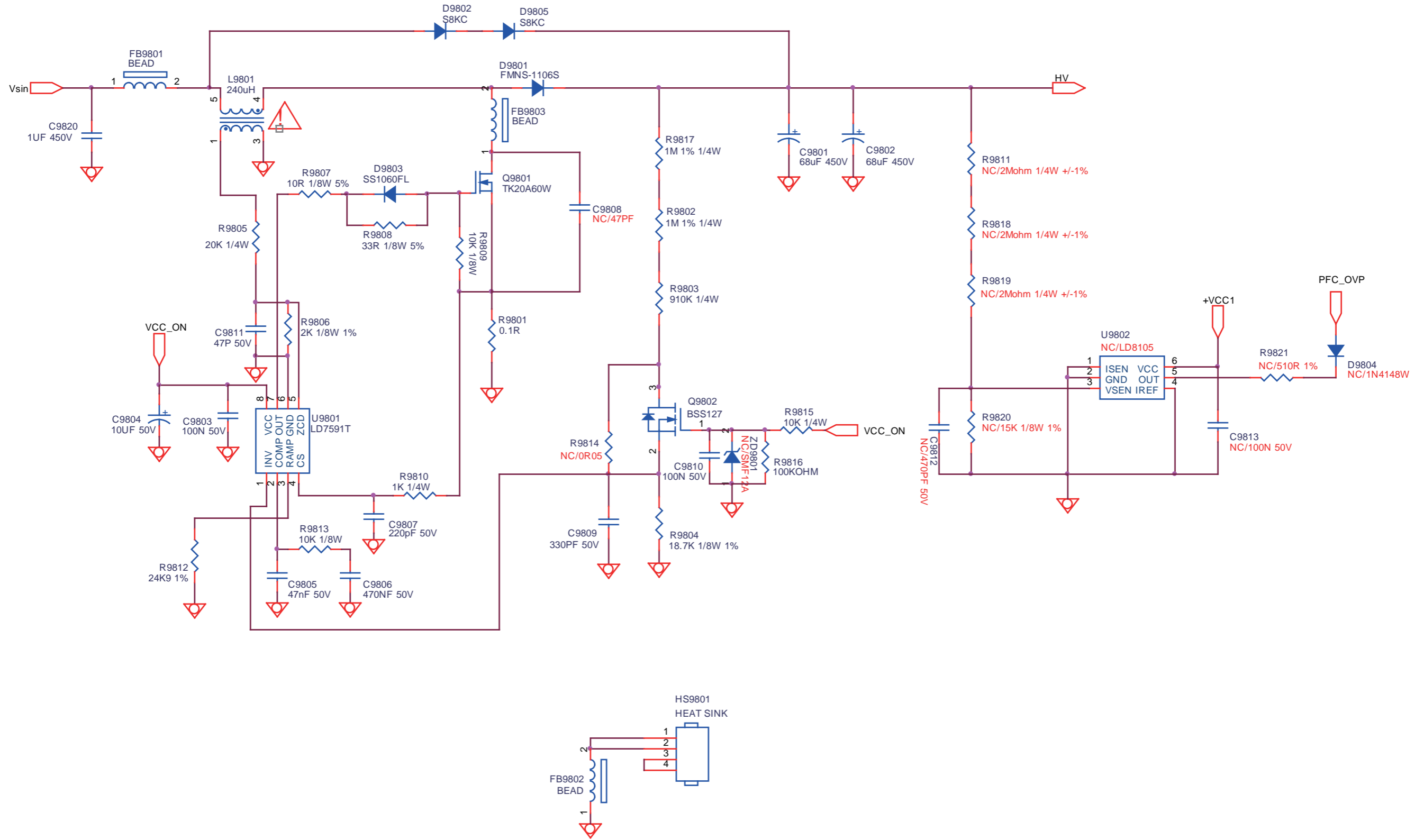

PFC	715G7350	2016-11-18

A03 Main Power

A03

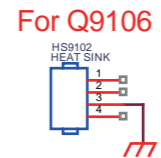
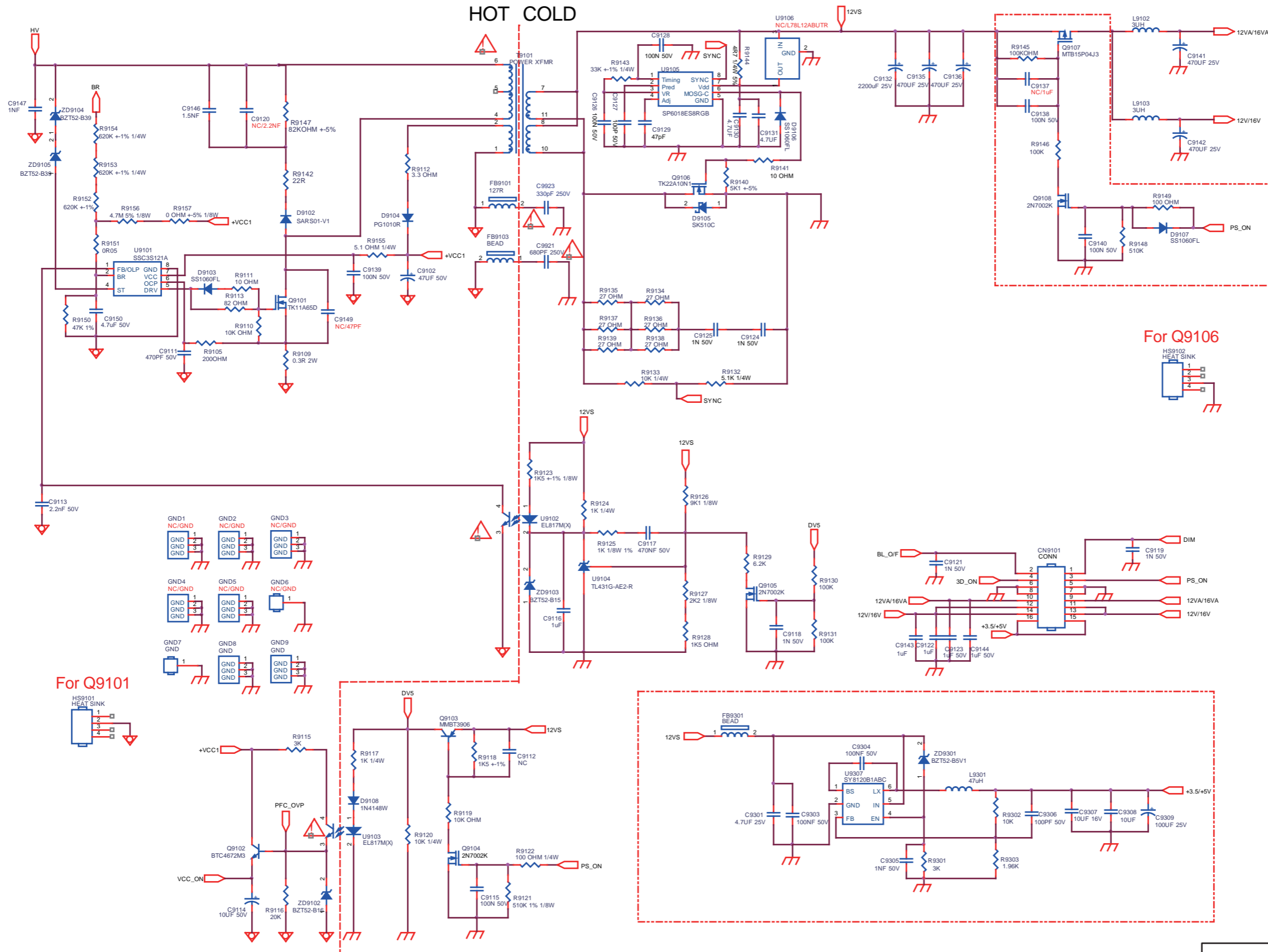

Main Power	715G7350	2016-11-18
------------	----------	------------

10-6-4 LED

A04

LED

A04

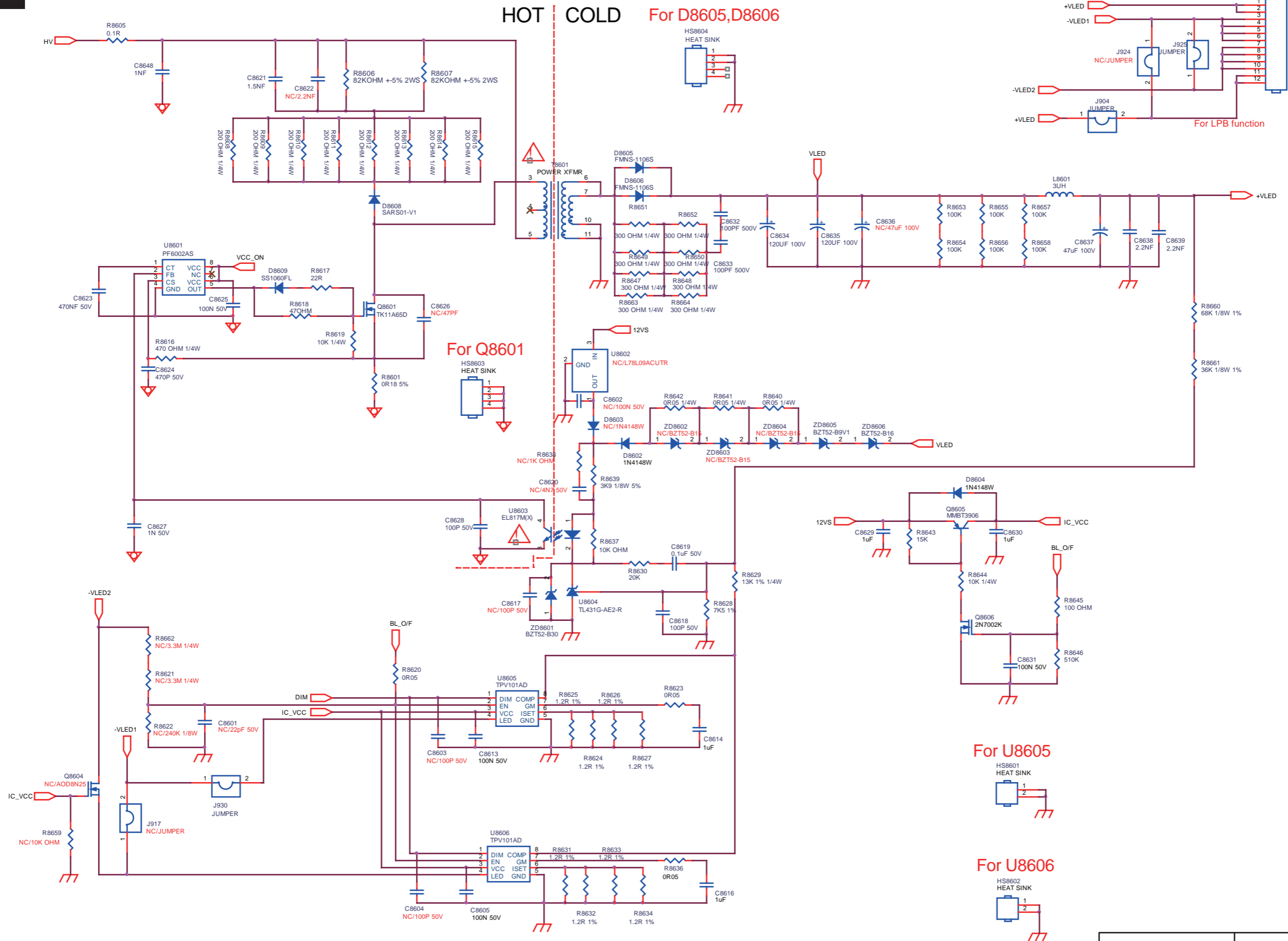

HOT COLD For D8605, D8606

For Q8601

For U8605

For U8606

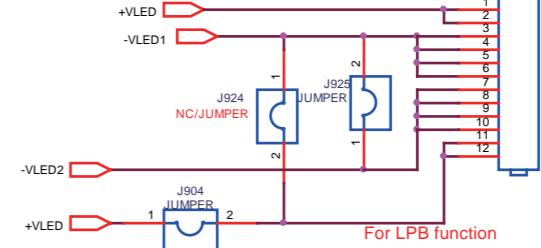

LED	715G7350	2016-11-18
-----	----------	------------

10-6-5 Power layout top

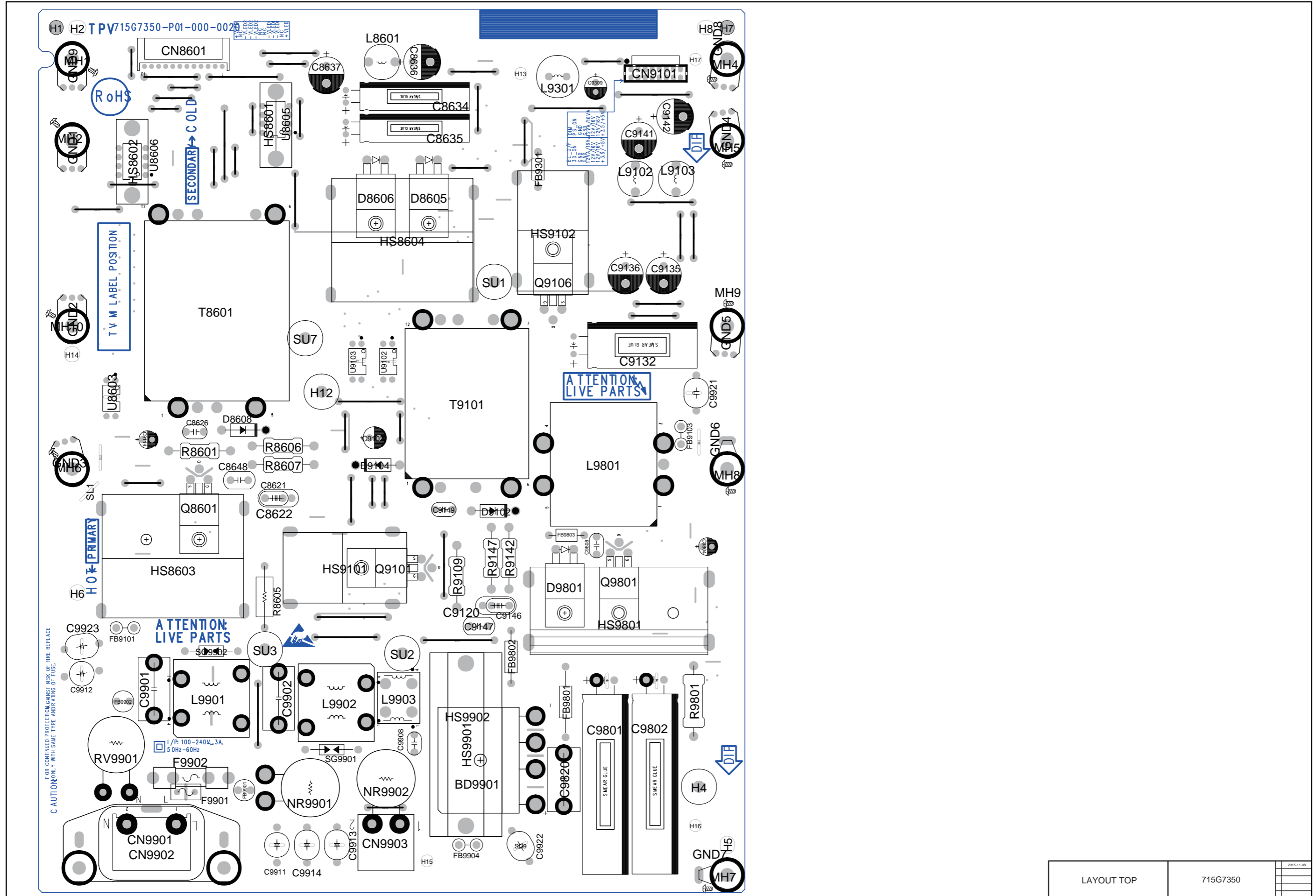

LAYOUT TOP	715G7350	2016-11-08
------------	----------	------------

10-6-6 Power layout bottom

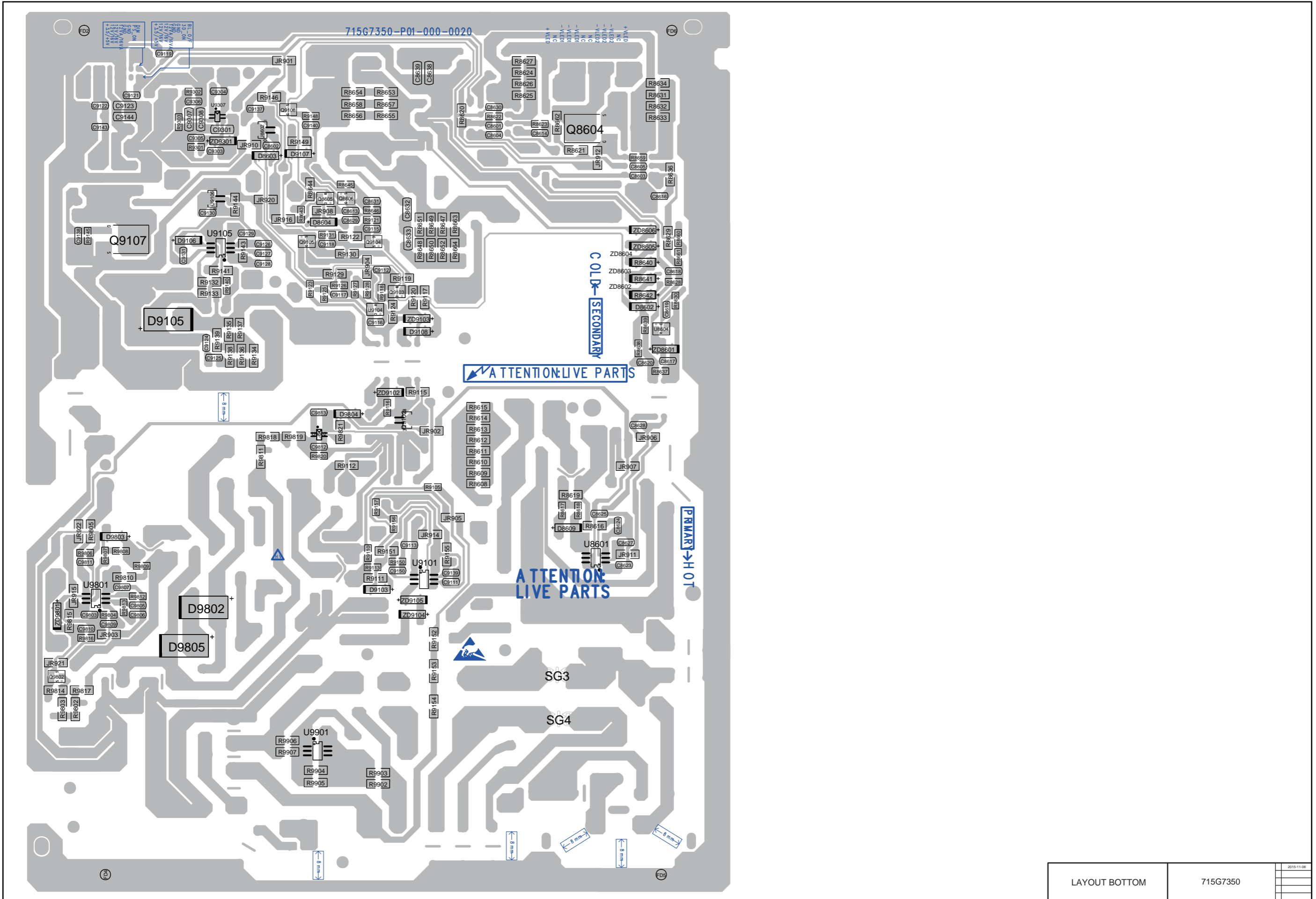

LAYOUT BOTTOM	715G7350	2016-11-08