

VUES EN ÉCLATÉ

GLM 5 GLM 5 HPE

Edition JANVIER 95

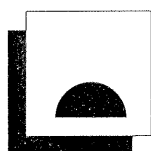

e.i.m. leblanc

TABLE DES PLANCHES

	Pages
GLM 5 15/16/20	
FAÇADE ET COTES	3
VUE INTERIEURE	4
BLOC GAZ ET VALVE EAU	5 et 6
TABLEAU ELECTRIQUE	7
CABLAGE DU TABLEAU ELECTRIQUE	8
SCHEMA ELECTRIQUE	9
BORNIER DE RACCORDEMENT ELECTRIQUE	10
DOSSERET	11
VMC	12
GLM 5 H PE (sans veilleuse)	
HABILLAGE	13
DOSSERET	14
VUE INTERIEURE	15
BLOC GAZ ET VALVE EAU	16
TABLEAU ELECTRIQUE	17
RACCORDEMENTS ELECTRIQUES	18
SCHEMA ELECTRIQUE	19
AGENCES REGIONALES	20

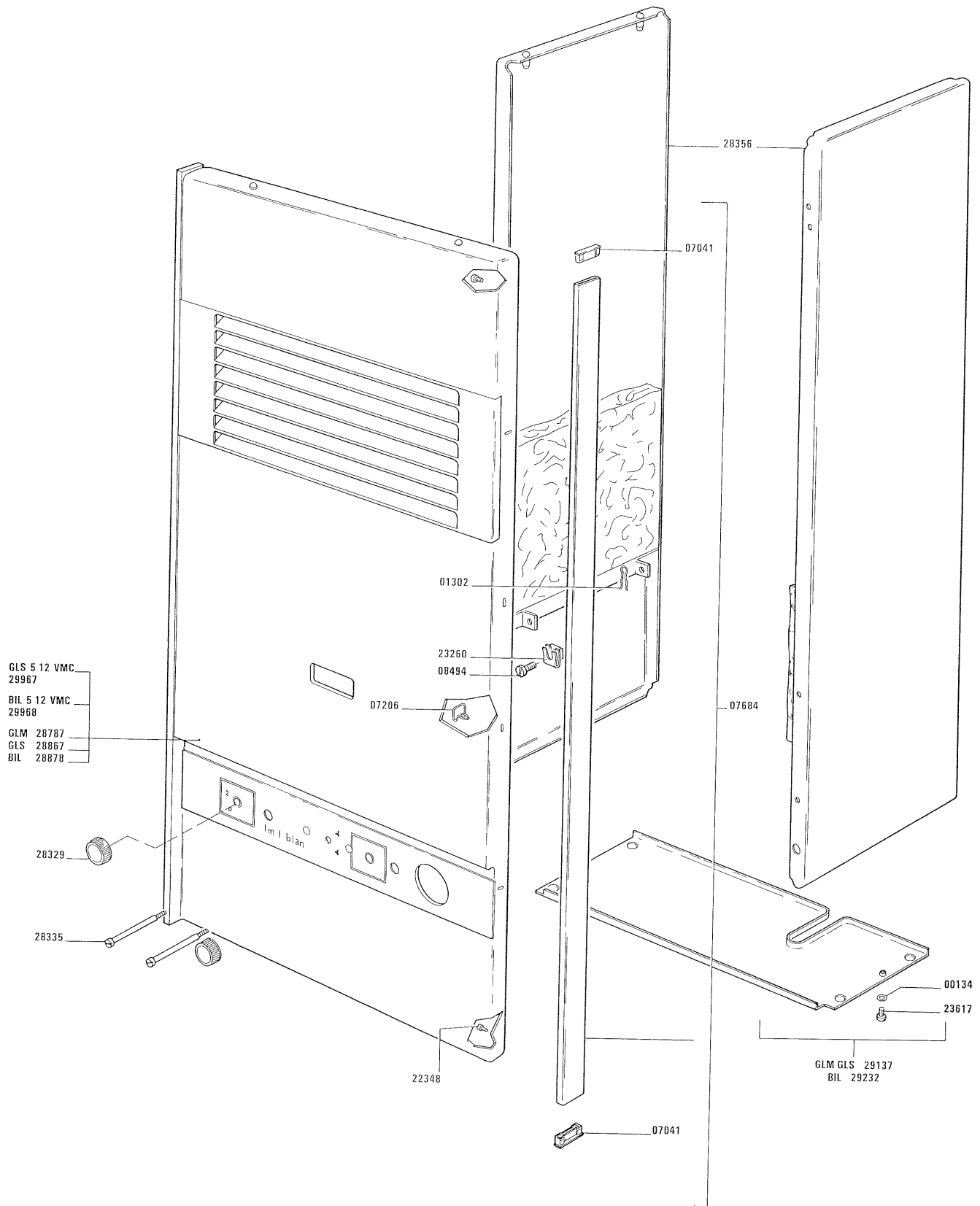

GLM 5 15 - 5 16 - 5 20
Façades et côtes

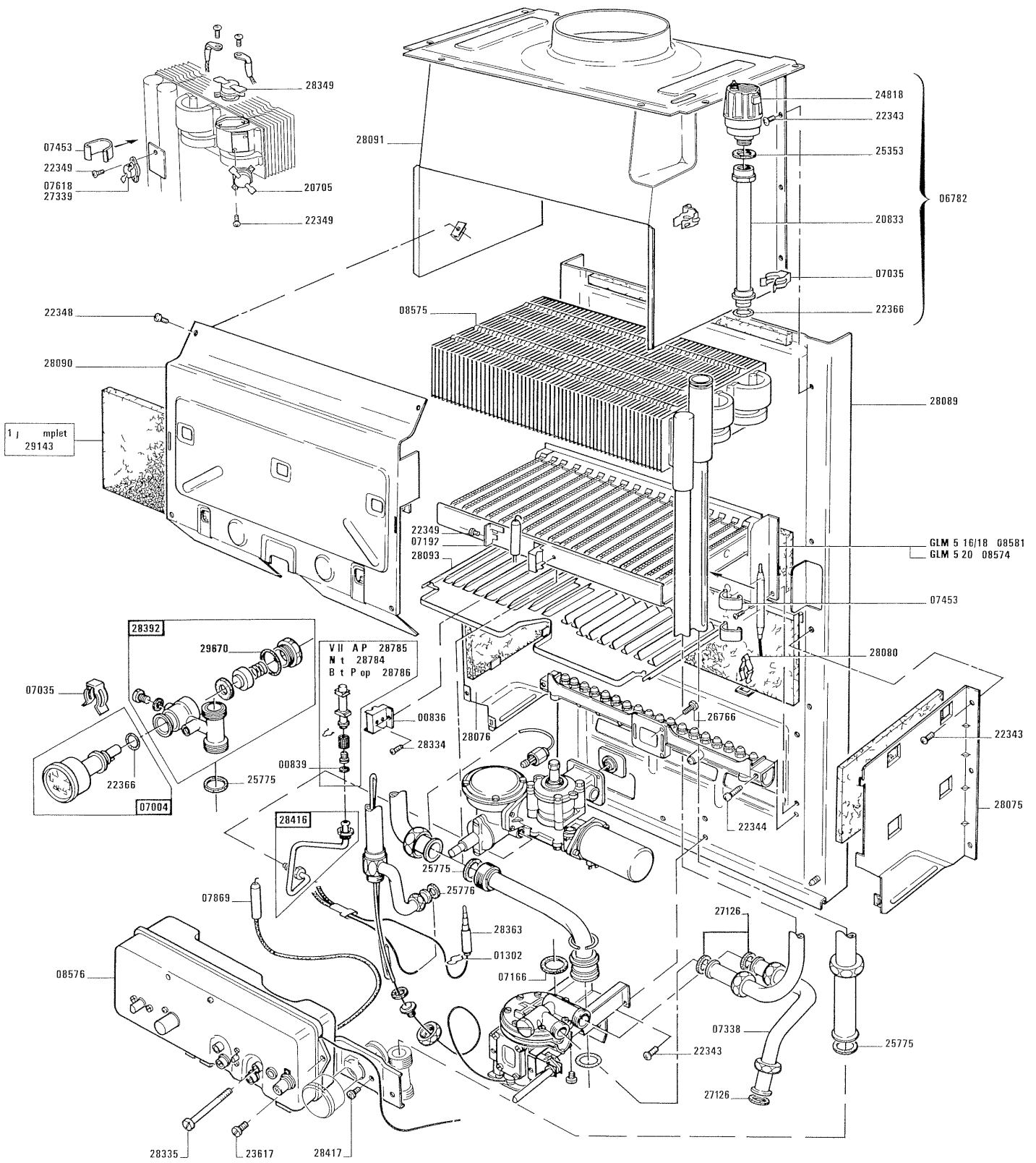

GLM 5 15 - 5 16 - 5 20

Vue interieure

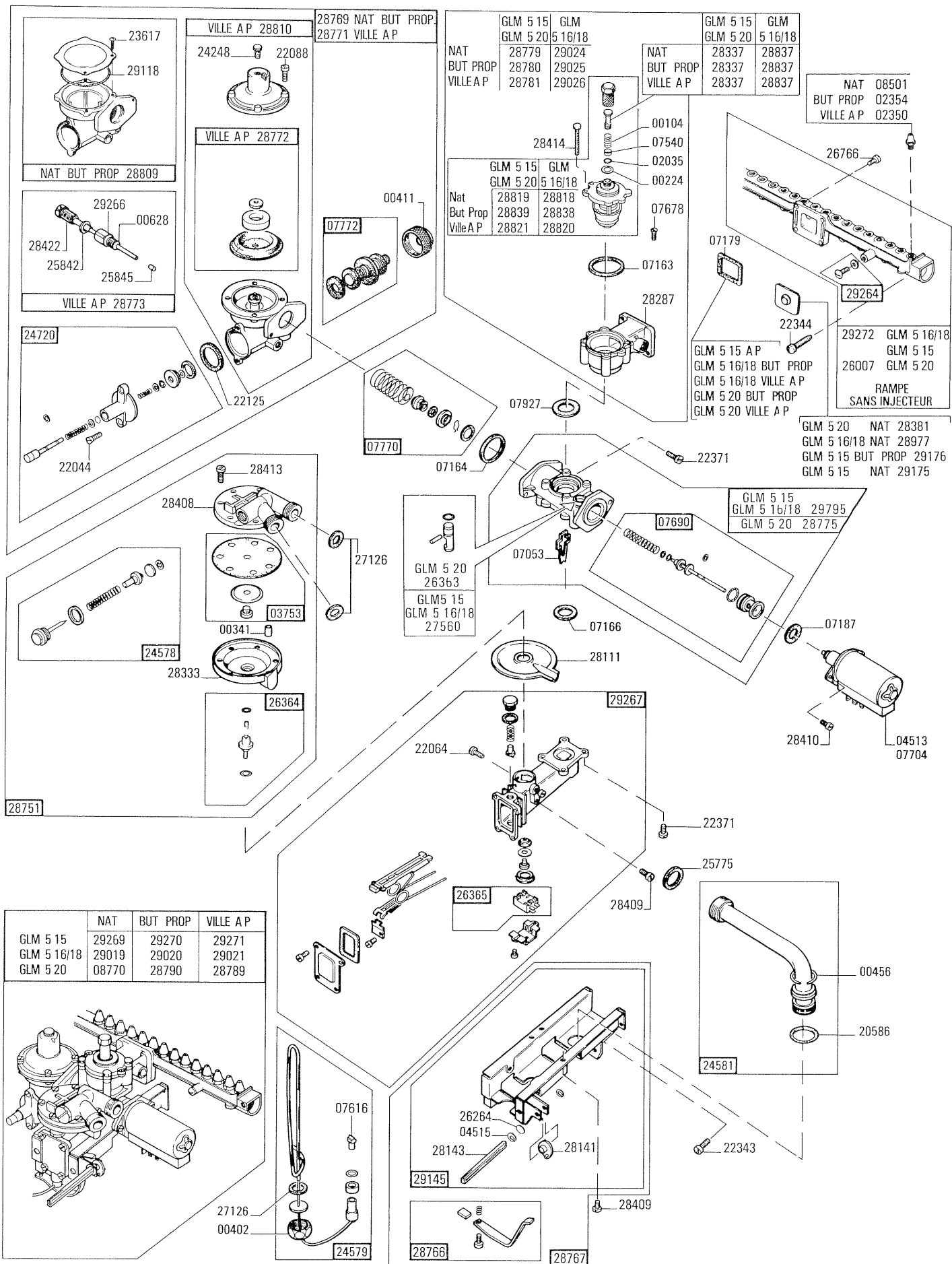

GLM 5 15 - 5 16/18 - 5 20

Bloc valve eau, valve gaz Boîtier de modulation
Regulateur gaz Rampe porte injecteurs

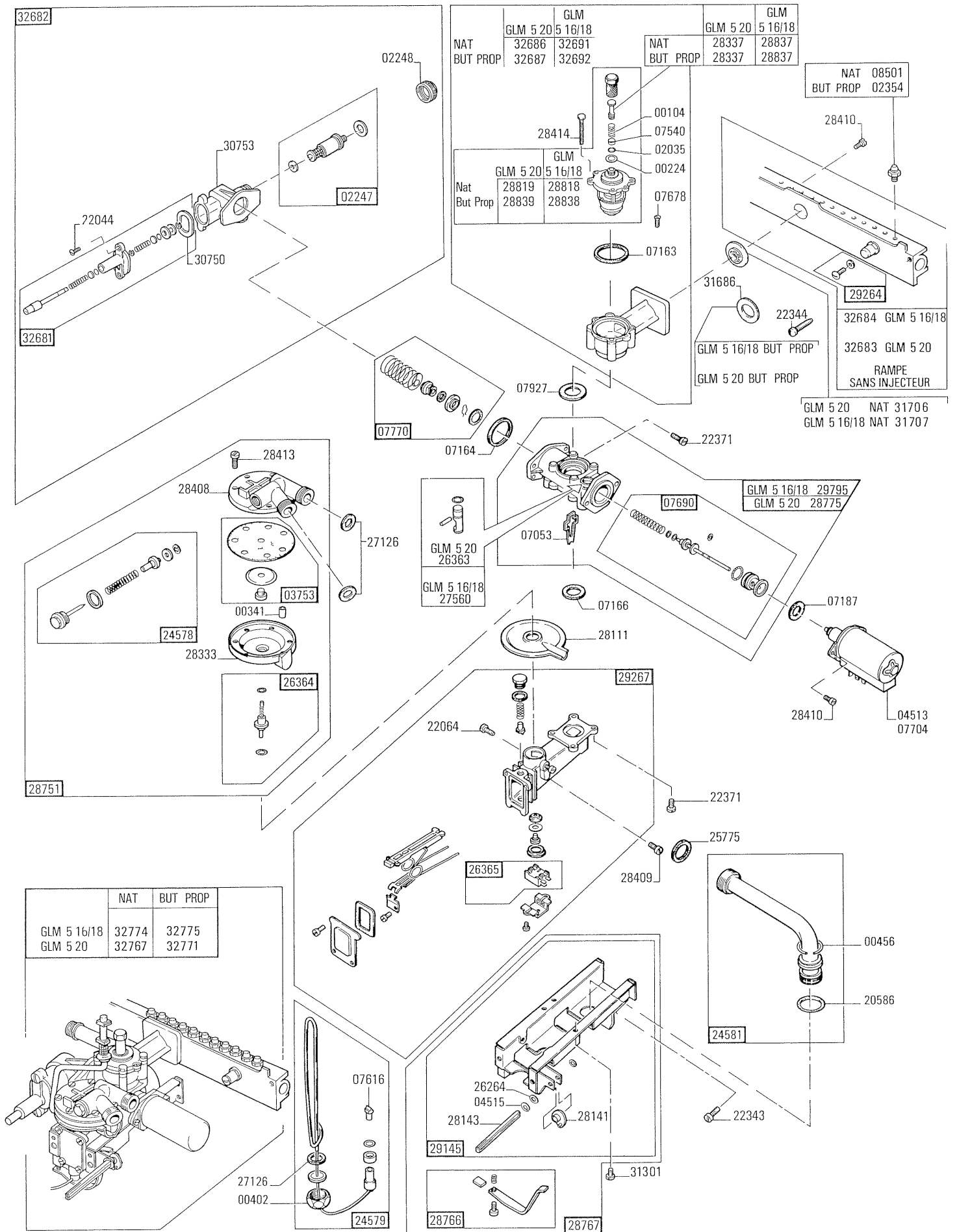

(A partir de juillet 82) **GLM 5 5.16/18 cN 5.20 cN** (GAZ NATURELS et BUT/PROP)

Bloc valve-eau, valve-gaz Boîtier de modulation
Valve de securite Rampe porte-injecteurs

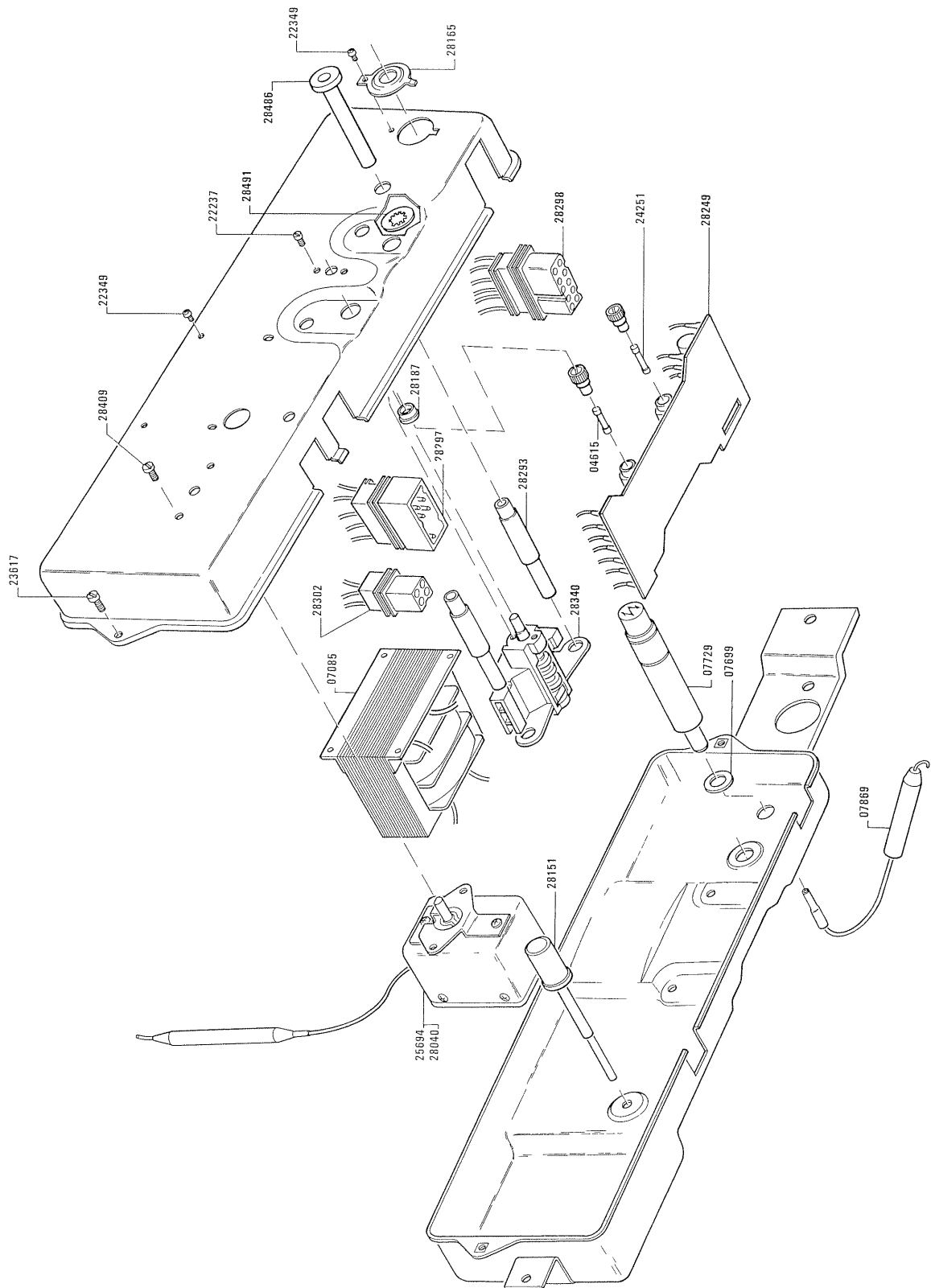

GLM 5.15 - 5.16 - 5.20 - 5.32
Tableau électrique

B	Bleu
Bl	Blanc
J	Jaune
M	Marron
N	Noir
R	Rouge
G	Gris
Sau	Saumon
Bei	Beige
Ro	Rose
O	Orange
Jv	Jaune/Vert

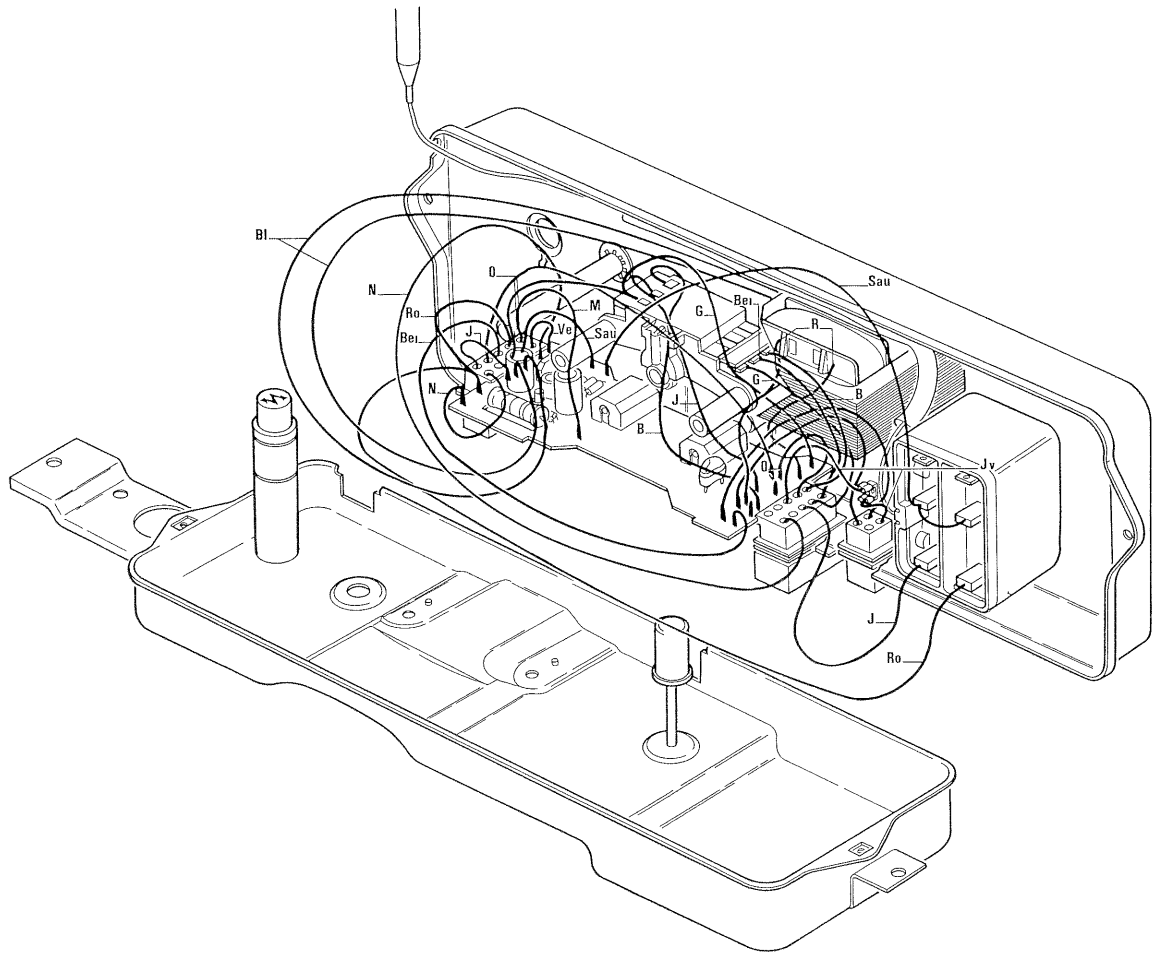

GLM 5.15 - 5.16 - 5.20 - 5.32
Câblage du tableau électrique

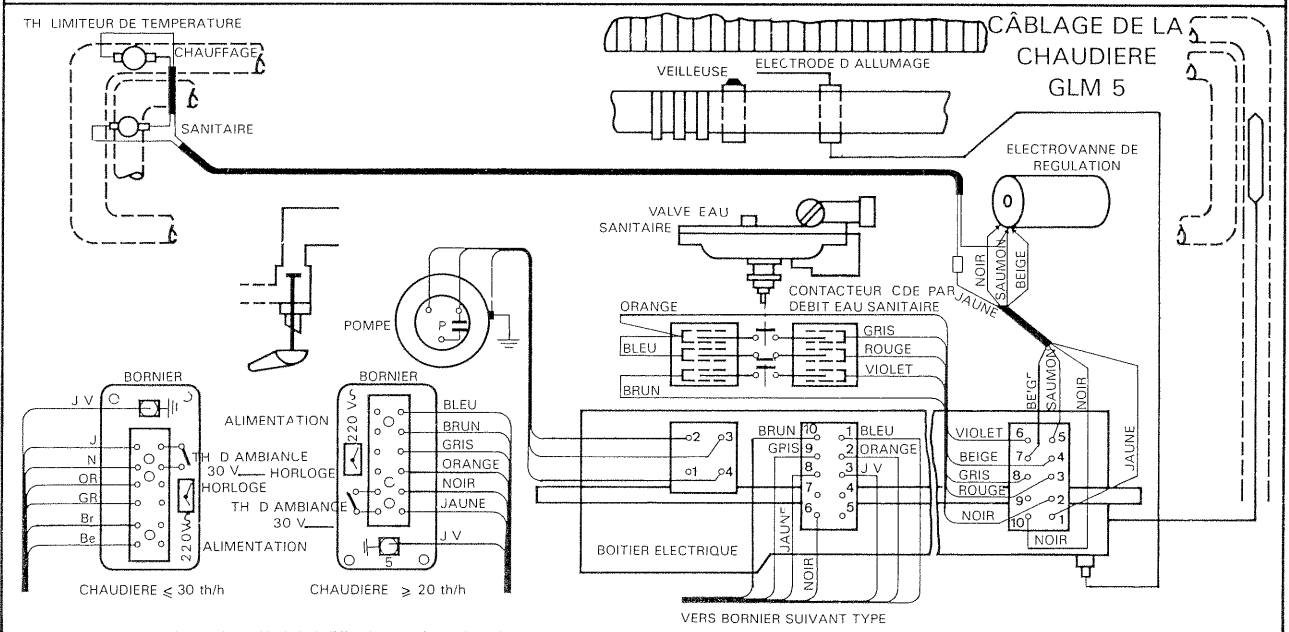
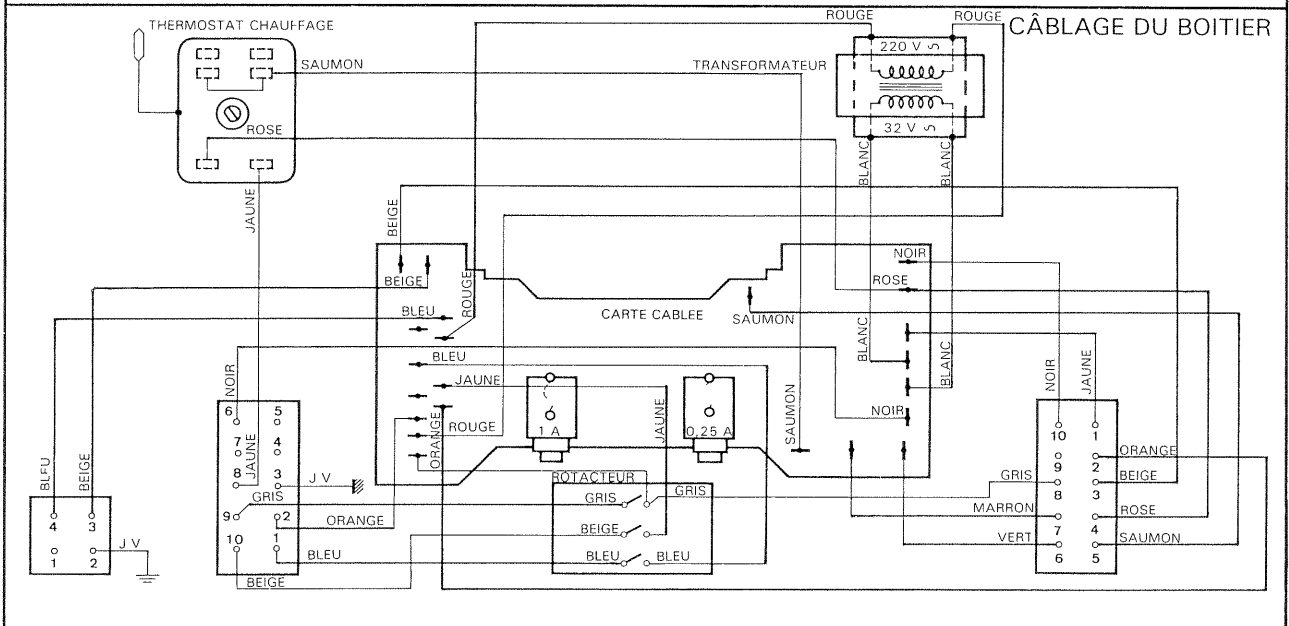
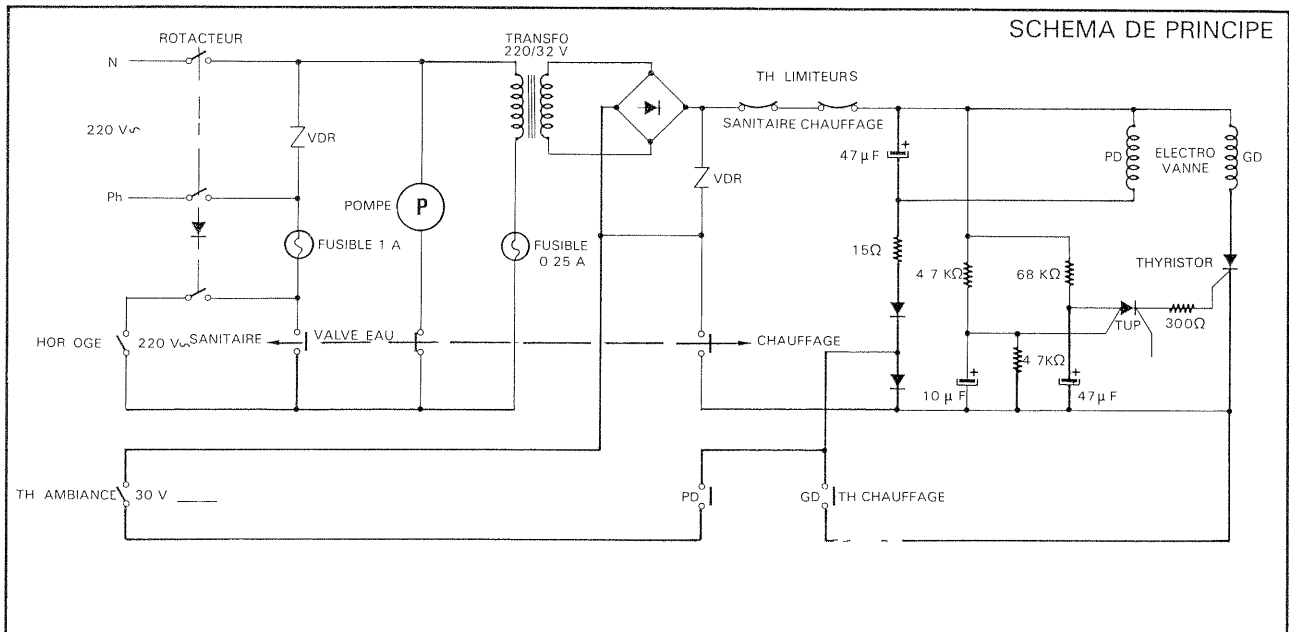

Schema de câblage, schema de principe

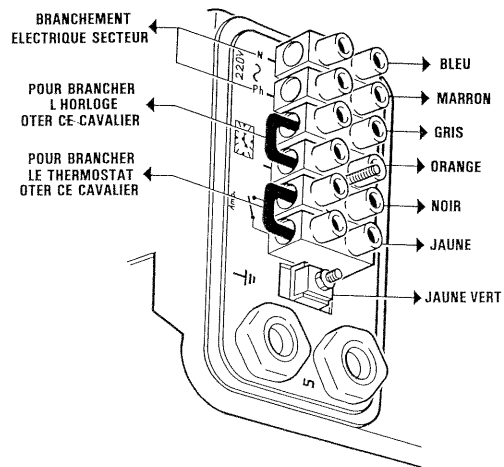
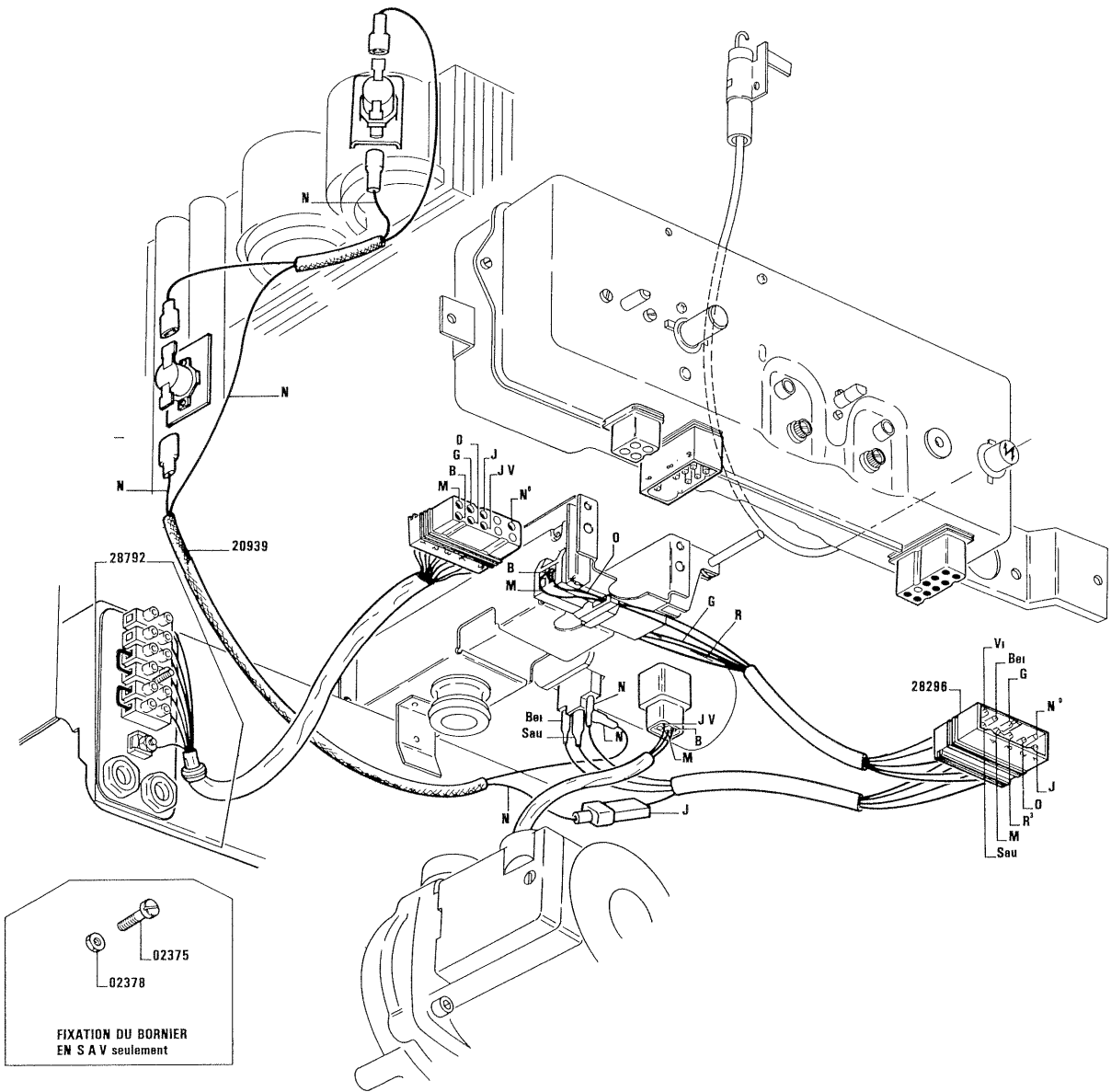

GLM 5.15 - 5.16 - 5.20
Raccordements électriques

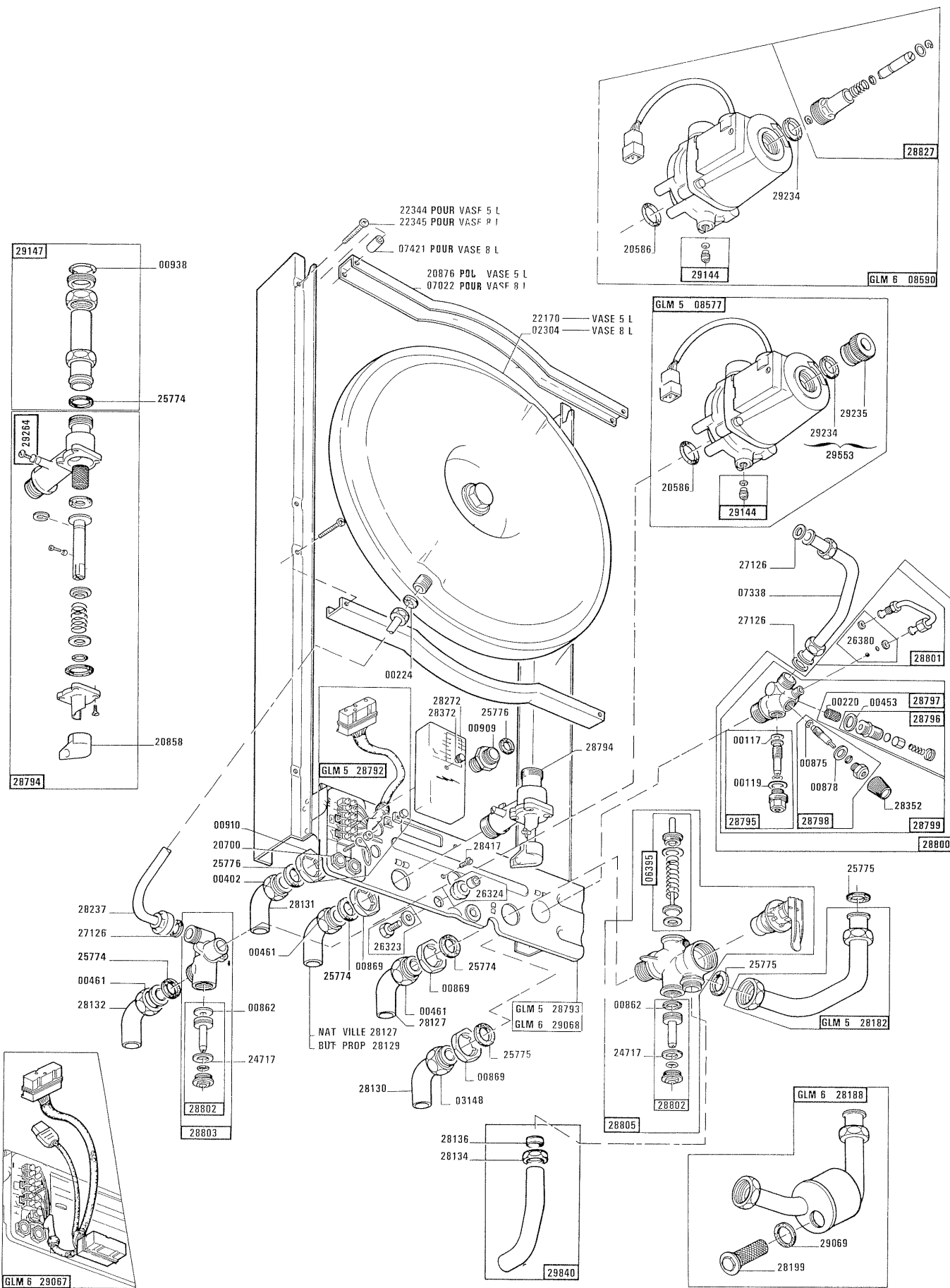

GLM 5.15 - 5.16 - 5.20 - 6.20
Dossieret porte-robinetterie
avec vase d'expansion incorpore 5 l ou 8 l

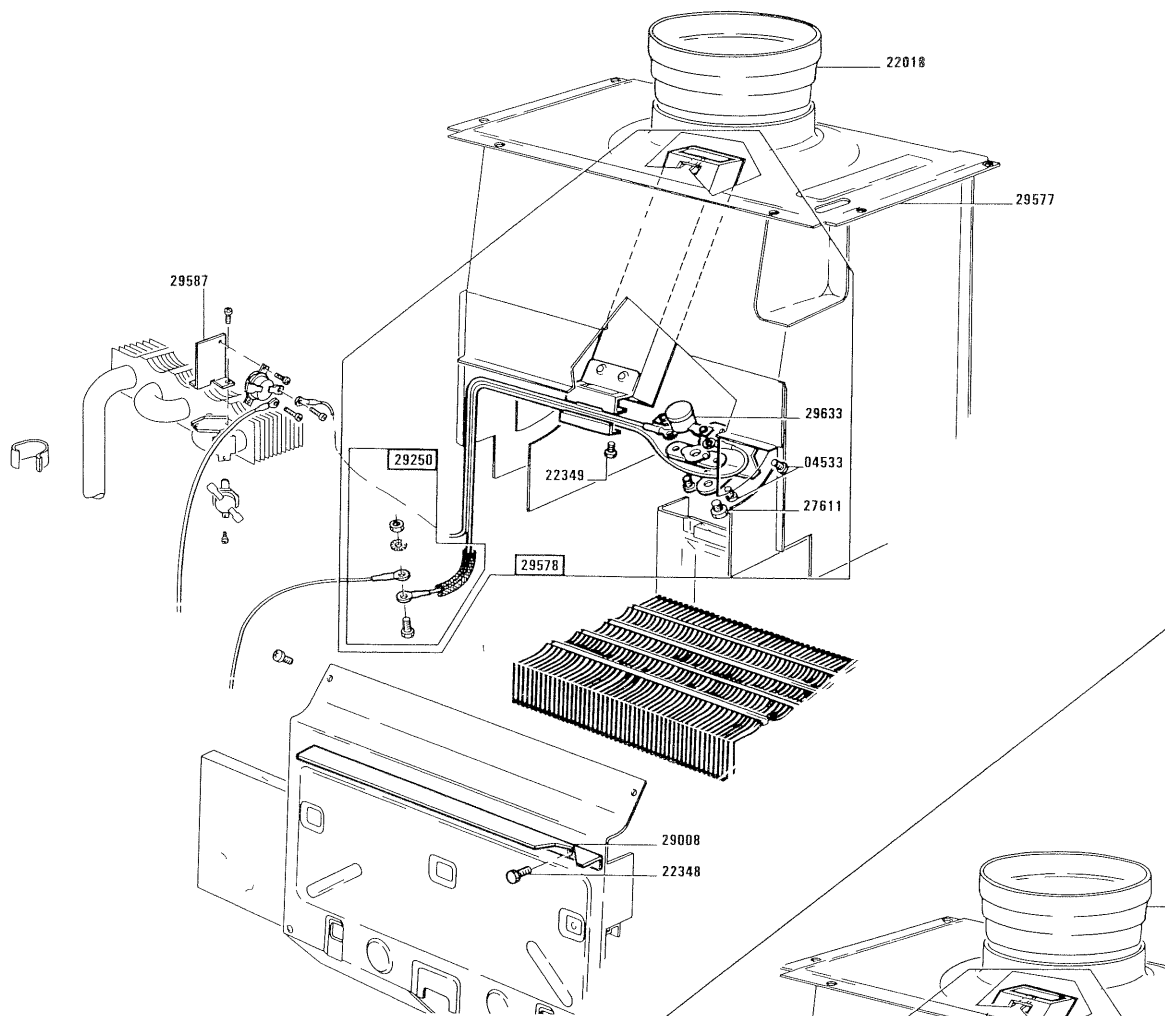

* Types 12000

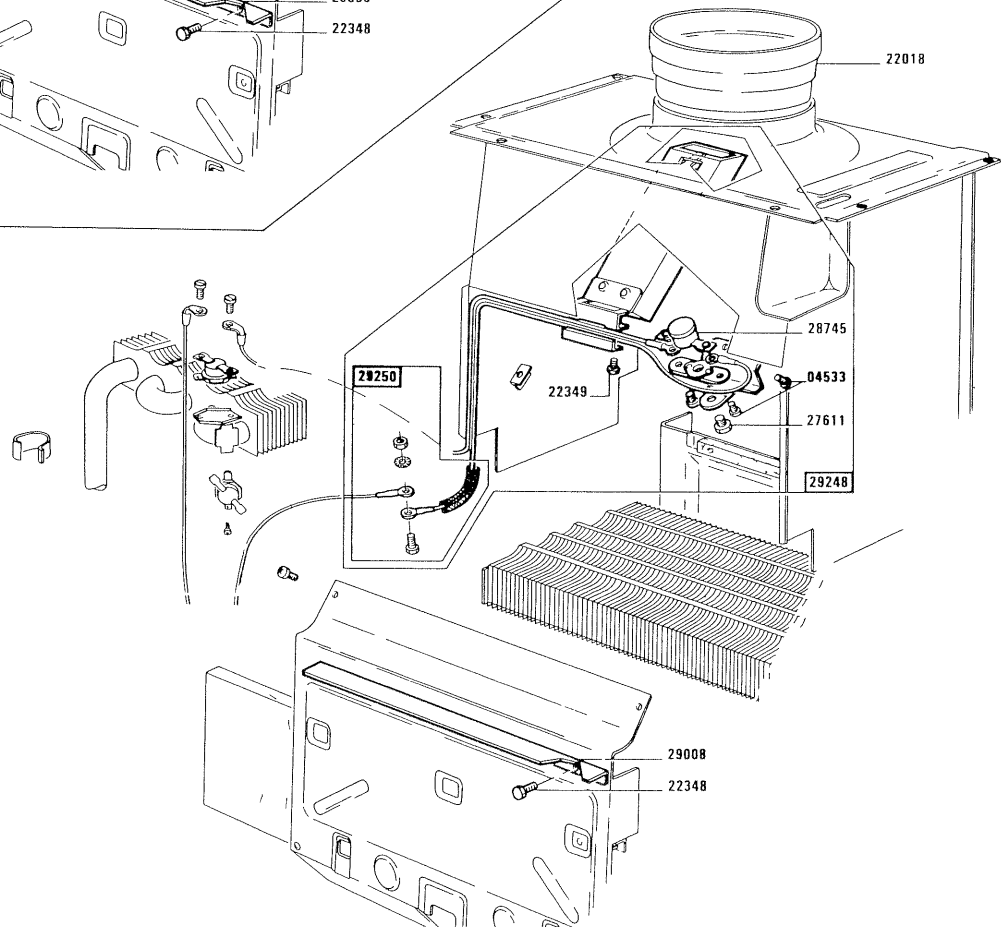

GLM 5.15 - 5.16 - 5.20 VMC
GLS 5.12*- 5.16 - 5.20 VMC
BIL 5.12*- 5.15 - 5.16 - 5.20 VMC

Pieces speciales pour systeme
de ventilation mecanique contrölee

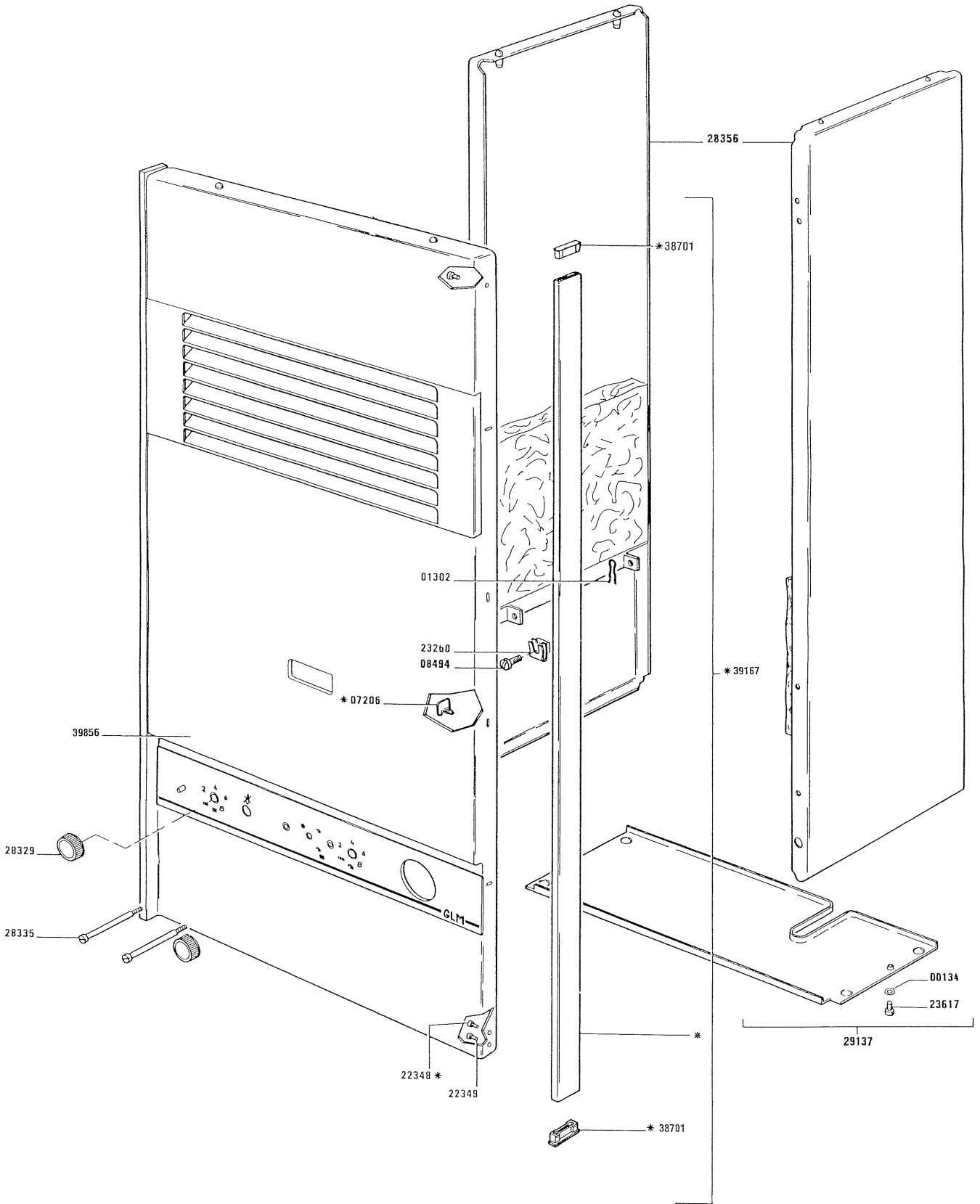

GLM 5 HPE
Habillage

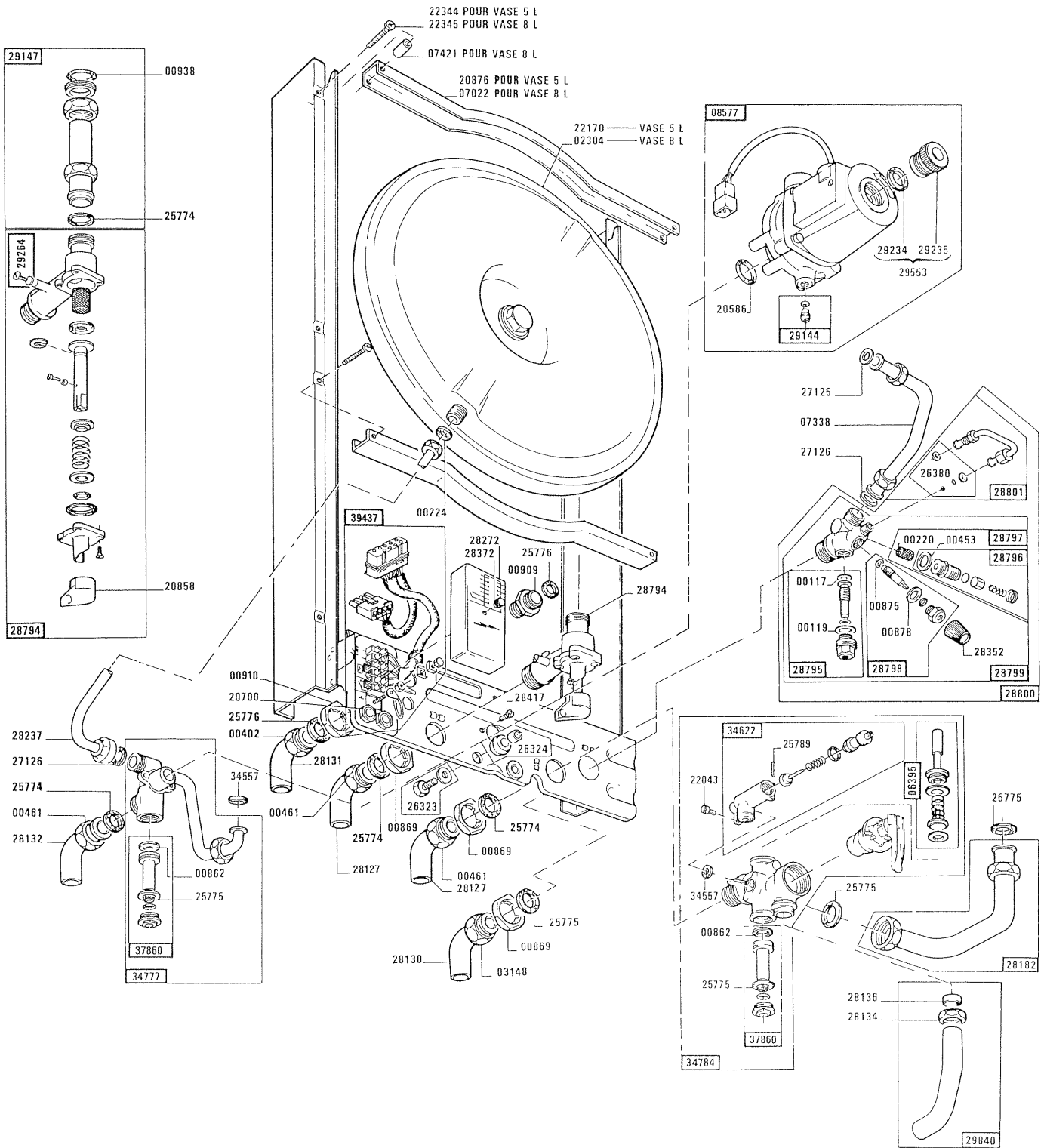

GLM 5 HPE
Dossieret porte-robinetterie
avec vase d'expansion incorpore
5 l ou 8 l

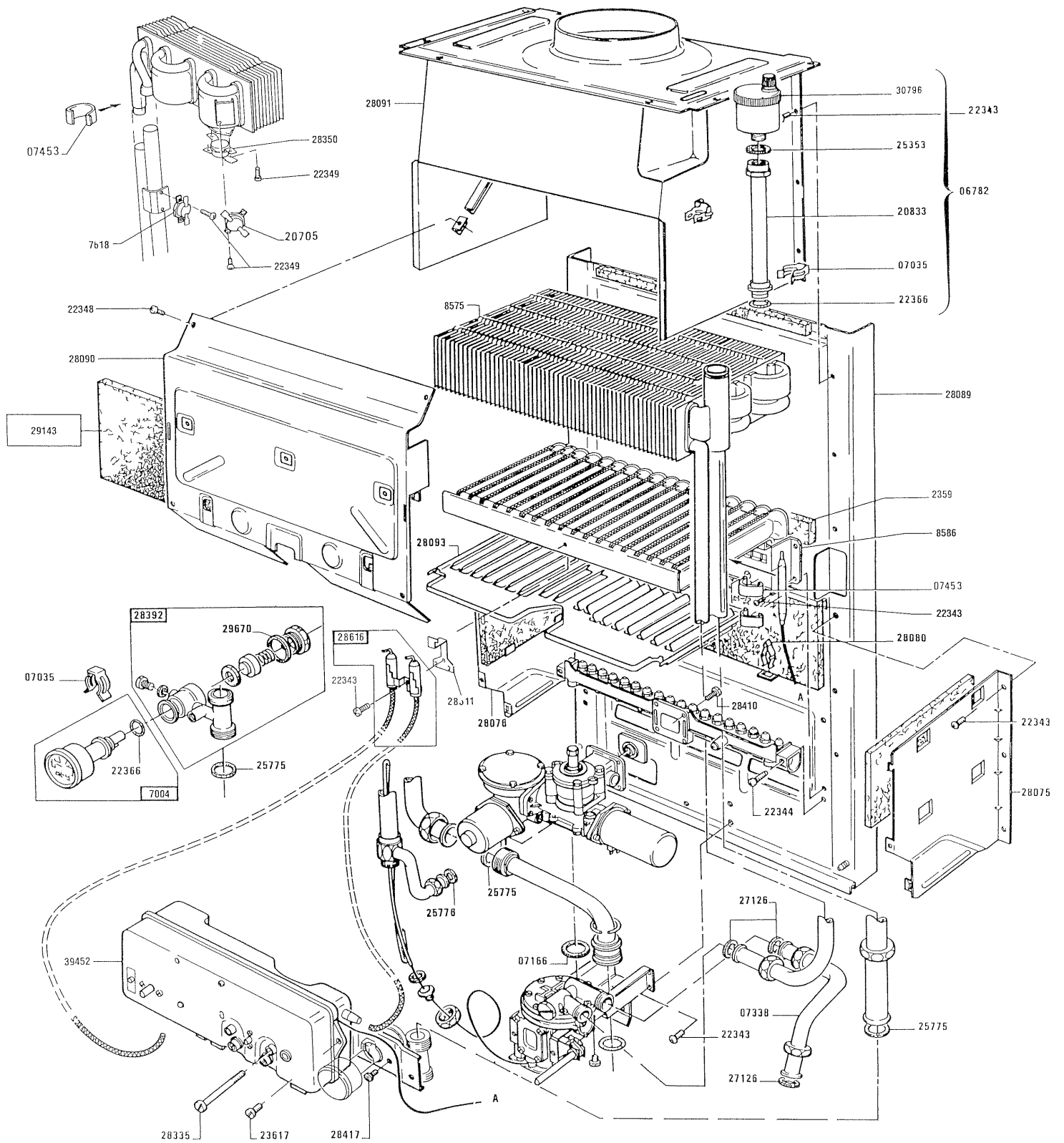

GLM 5 HPE
Vue interieure

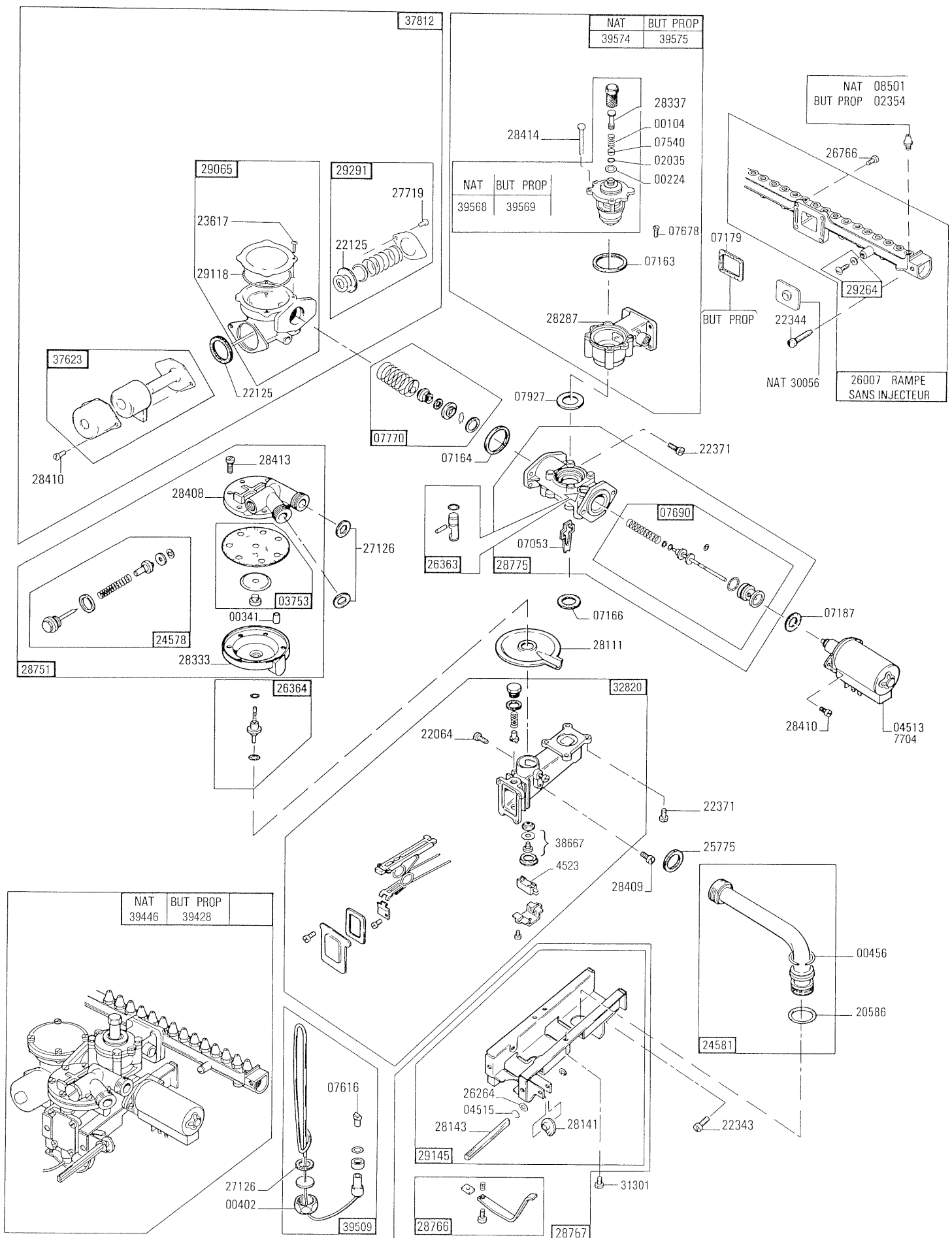

GLM 5 HPE

**Bloc valve-eau, valve-gaz Boîtier de modulation
Regulateur gaz Rampe porte-injecteurs**

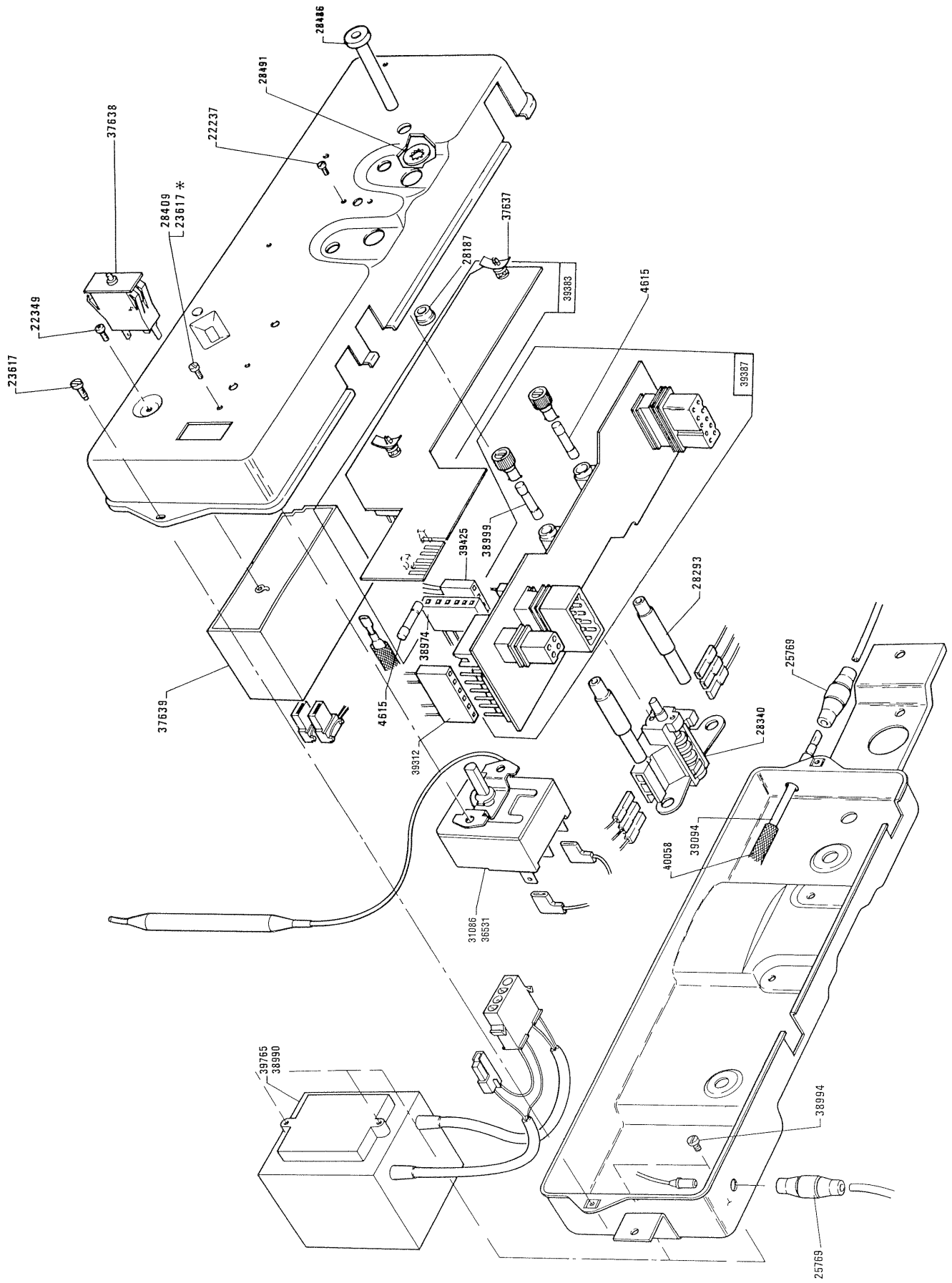

GLM 5 HPE
Tableau électrique

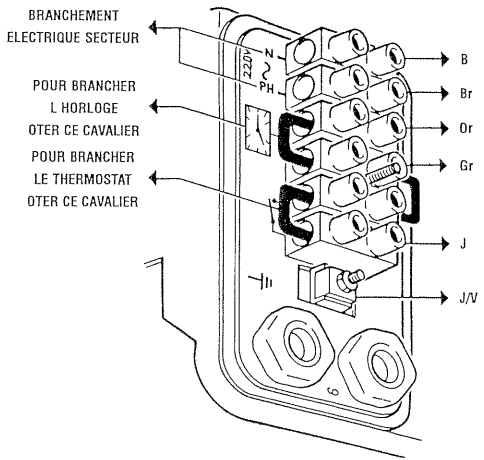
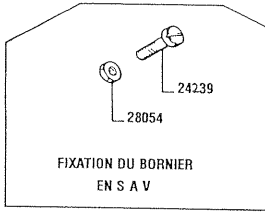
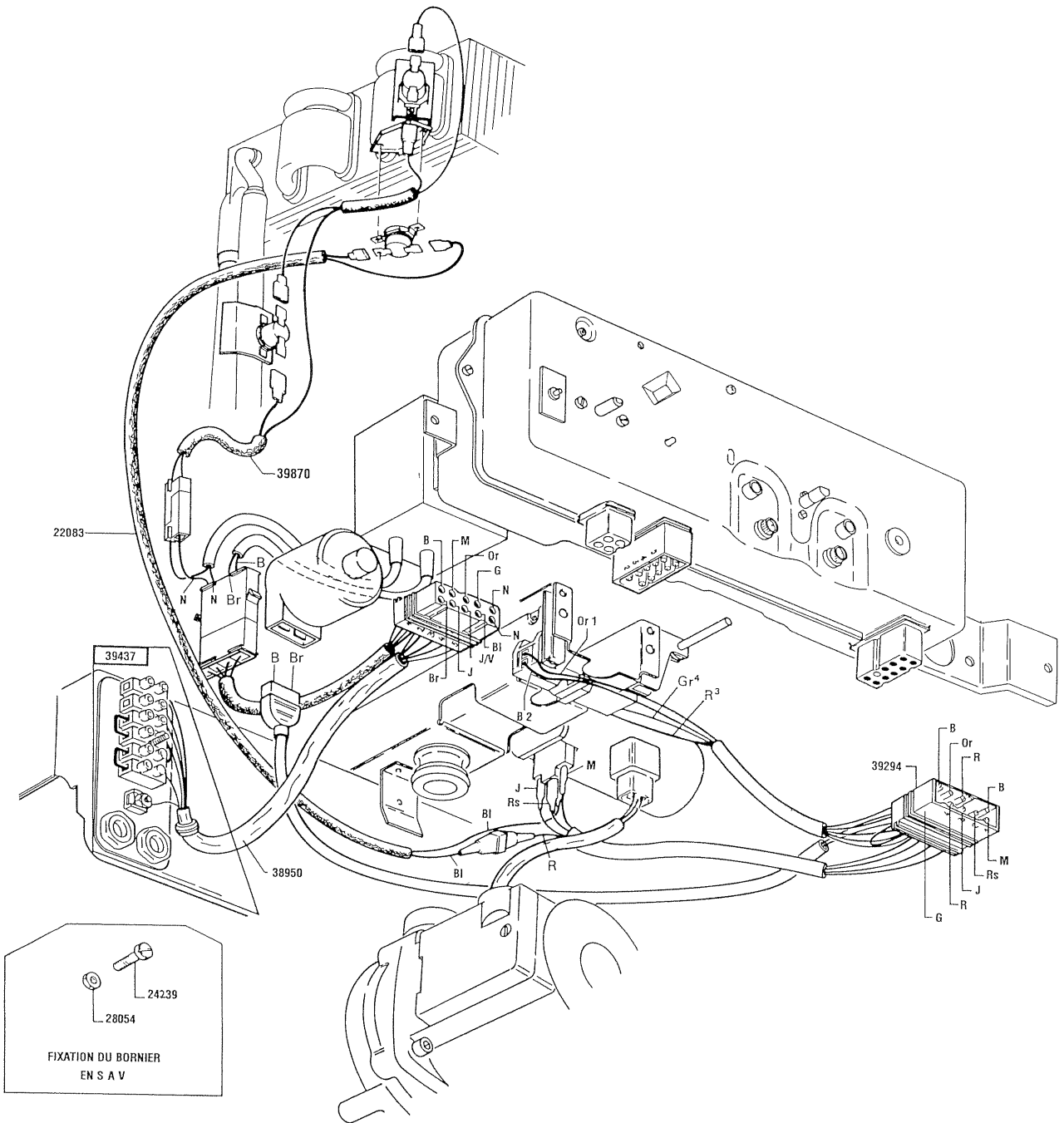

GLM 5 HPE
Raccordements electriques



Schéma de principe électrique



Câblage du boîtier

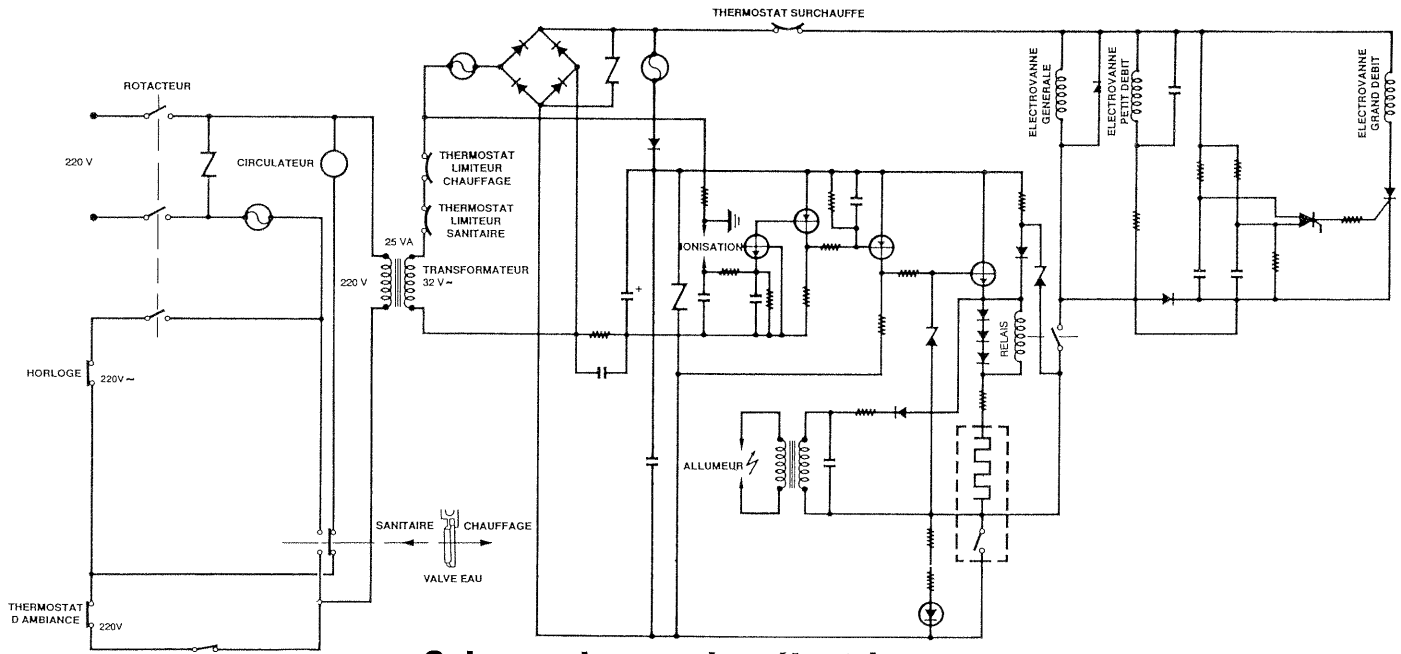
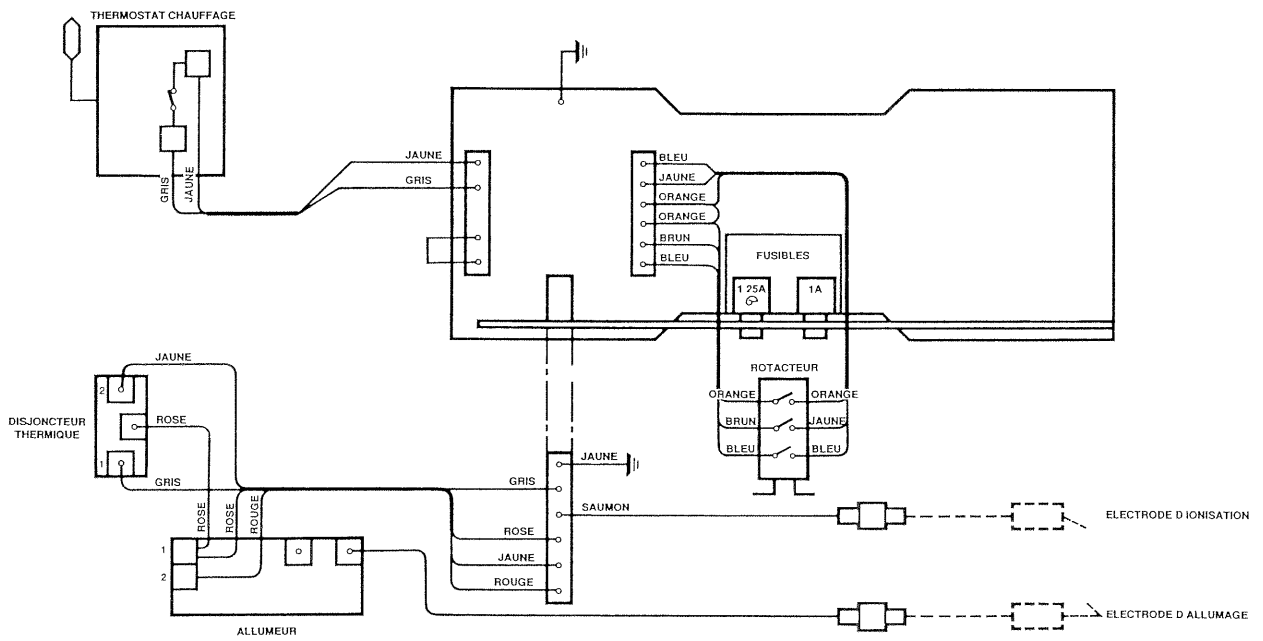
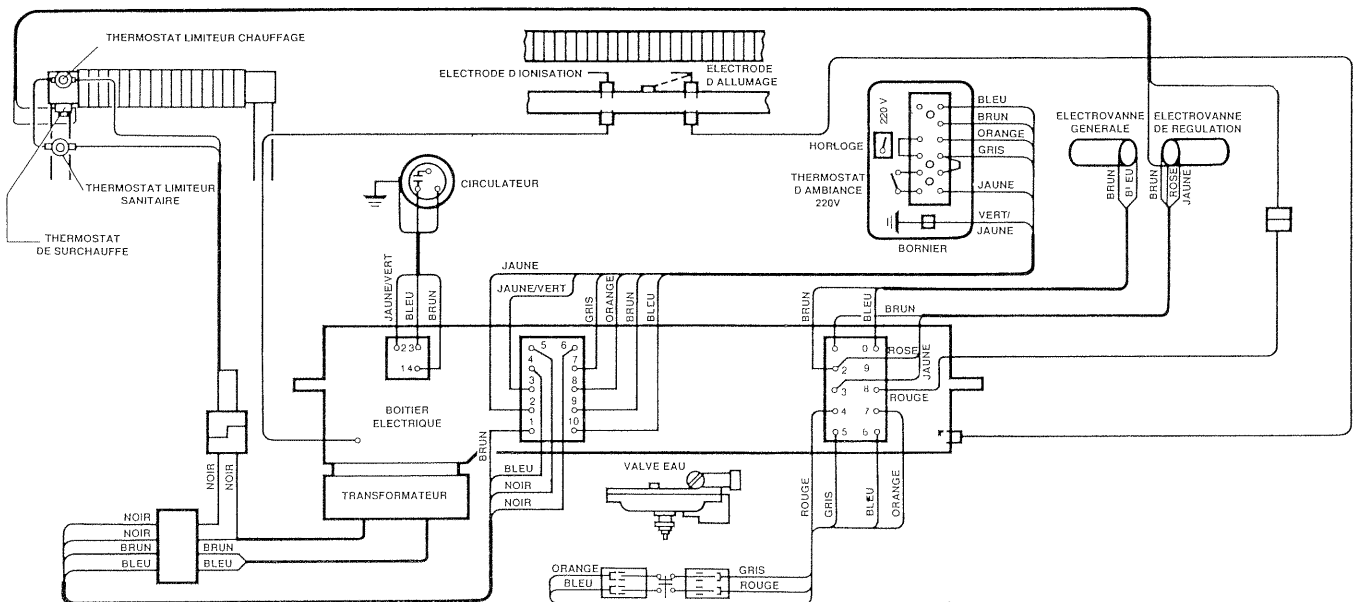

GLM 5 HPE

Câblage de la chaudière

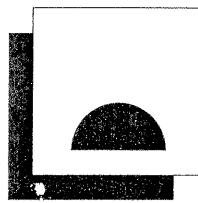

e.i.m. leblanc

CHAUFFE EAU
CHAUFFE BAINS
CHAUDIÈRES
MURALES

REGION PARISIENNE

93700 DRANCY Tel (1) 48 30 12 13
9 13 rue Emile Zola Fax (1) 48 96 87 00

92370 CHAVILLE Tel (1) 47 50 50 33
70 rue Roger Salengro Fax (1) 47 09 90 56

92700 COLOMBES Tel (1) 47 60 03 36
4 av de Stalingrad Fax (1) 47 81 33 29

75011 PARIS Tel (1) 43 55 26 50
22 bd Richard Lenour Fax (1) 43 57 69 98

75017 PARIS Tel (1) 42 63 25 56
31 rue Brochant Fax (1) 42 63 39 29

94200 IVRY SUR SEINE Tel (1) 49 60 69 03
26 rue Robert Witzitz Fax (1) 49 59 08 80

REGION OUEST

14000 CAEN Tel 31 52 08 31
69 rue Victor Lepine Fax 31 34 96 32

44100 NANTES Tel 40 76 94 91
46 bd Boulay Paty Fax 51 83 92 54

35000 RENNES Tel 99 38 58 34
83 bd de Metz Fax 99 63 79 04

REGION CENTRE LOIRE

18000 BOURGES Tel 48 70 84 12
12 rue Florentin Labbe Fax 48 69 05 23

45000 ORLEANS Tel 38 62 23 18
10 rue du Marechal Foch Fax 38 81 04 63

37700 TOURS ST PIERRE DES
CORPS Tel 47 44 33 40
24 av Lenine Fax 47 37 81 48

REGION AQUITAINE LIMOUSIN

33800 BORDEAUX Tel 56 92 78 17
102 rue Francin Fax 56 92 05 19

87100 LIMOGES Tel 55 77 31 87
2 impasse Daguerre Fax 55 79 51 88

REGION MIDI PYRENEES

64200 BIARRITZ Tel 59 03 84 93
7 rue du Lycee Fax 59 03 96 49

64000 PAU Tel 59 27 11 96
8 rue Baudon Fax 59 27 47 97

66000 PERPIGNAN Tel 68 61 13 68
6 rue Guillaume Apollinaire Fax 68 52 52 44

31200 TOULOUSE Tel 61 47 70 60
64 rue de Fenouillet Fax 62 72 01 69

REGION NORD

59000 LILLE Tel 20 52 28 56
8 rue Moliere Fax 20 88 43 42

REGION EST

25220 BESANÇON
Roche lez Beaupre Tel 81 80 73 71
Z I de Thuse Fax 81 50 16 41

54000 NANCY Tel 83 35 02 84
6 rue Foller Fax 83 37 23 67

57000 MI TZ Tel 87 63 23 02
105 rue Kellermann Fax 87 56 07 90

51010 REIMS
Z A LA NEUVILLETTE Tel 26 04 89 65
24 rue de Betheny Fax 26 04 89 63

67000 STRASBOURG Tel 88 36 06 85
31 rue du Fosse des Treize Fax 88 23 20 02

REGION SUD EST

13010 MARSEILLE Tel 91 78 67 00
97 99 av de la Timone Fax 91 83 07 21

34000 MONTPELLIER Tel 67 65 76 75
49 rue Frederic Bazille Fax 67 22 59 28

06300 NICE Tel 93 89 64 10
19 rue Beaumont Fax 93 89 35 67

83200 TOULON Tel 94 24 31 86
13 rue Gortier Fax 94 24 38 21

84000 AVIGNON Tel 90 89 10 51
23 route de Montfavet Fax 90 87 74 38

REGION AUVERGNE RHONE ALPES

69008 LYON Tel 78 00 02 39
154 av du General Freire Fax 78 76 26 09

03100 MONTLUÇON Tel 70 29 09 96
34 quai de Verdun Fax 70 29 96 50

38000 GRENOBLE Tel 76 49 53 60
10 rue Leon Sestier Fax 76 70 26 76
Z A le GEAI

63540 CLERMONT FD Tel 73 62 00 00
ROMAGNAT LES PEROUSES Fax 73 61 13 69

SIEGE SOCIAL 123 125 RUE DIDEROT - 93700 DRANCY
TEL (1) 48 30 11 12 - TELECOPIEUR (1) 48 30 86 21 - TELEX LEBLANC

SA AU CAPITAL DE 22 321 580 F RCS BOBIGNY B 542 097 944