

# 13 Schematic Diagrams

## 13-1 SMPS Part Schematic Diagram

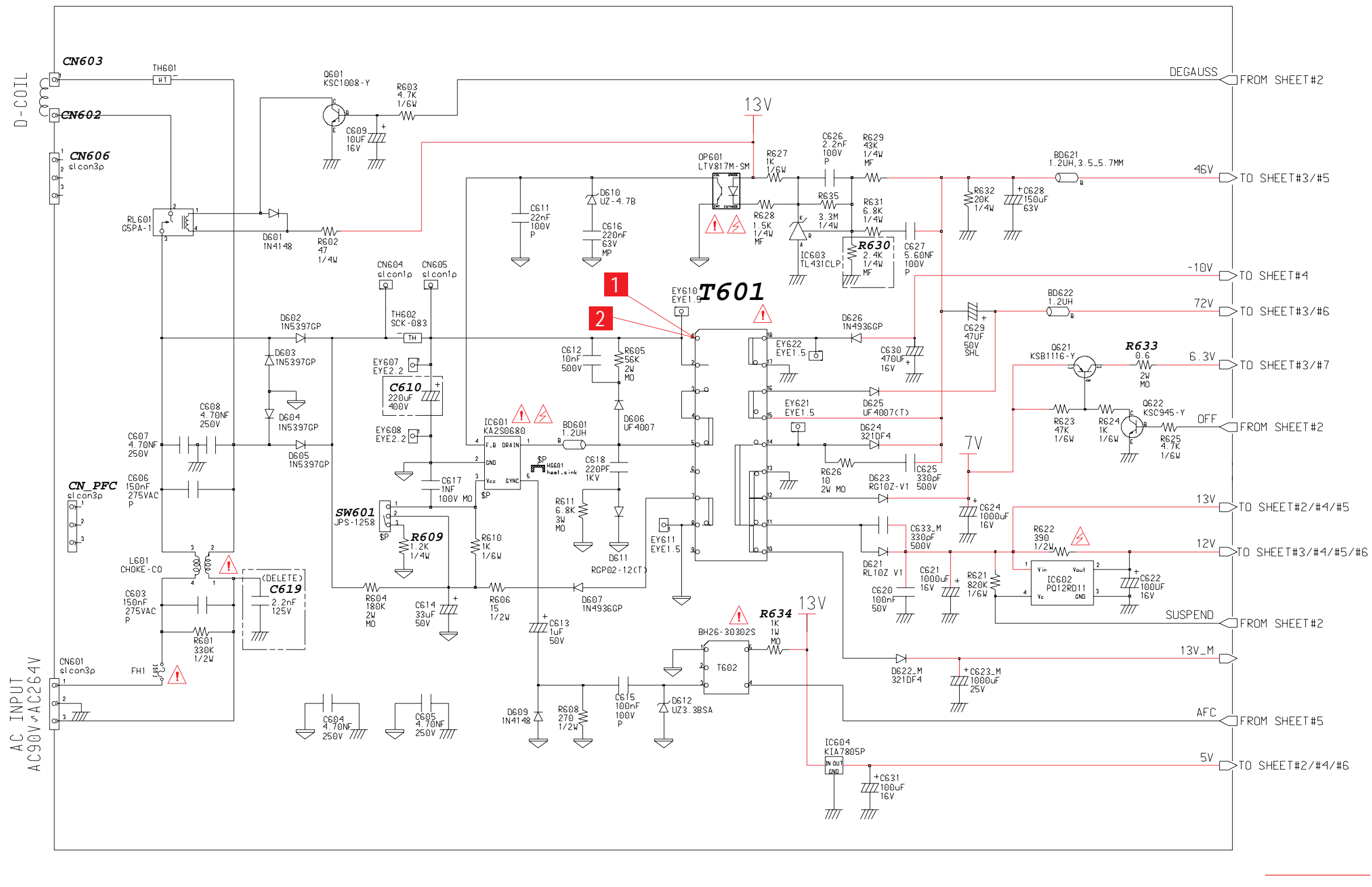

Power Line

Table 13-1. IC601 (KA2S0680)

pin #	MODES	
	800 x 600 / 85 Hz	640 x 480 / 60 Hz
1	1.05	10.30
2	GND	GND
3	-33.2 mV	-34.0 mV
4	-57.0 mV	-48.0 mV
5	-42.0 mV	-46.0 mV

Unit: Vrms

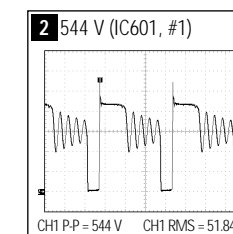
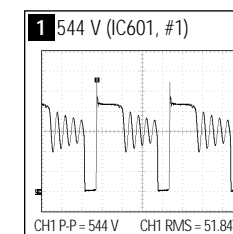

13-2 Micom Part Schematic Diagram

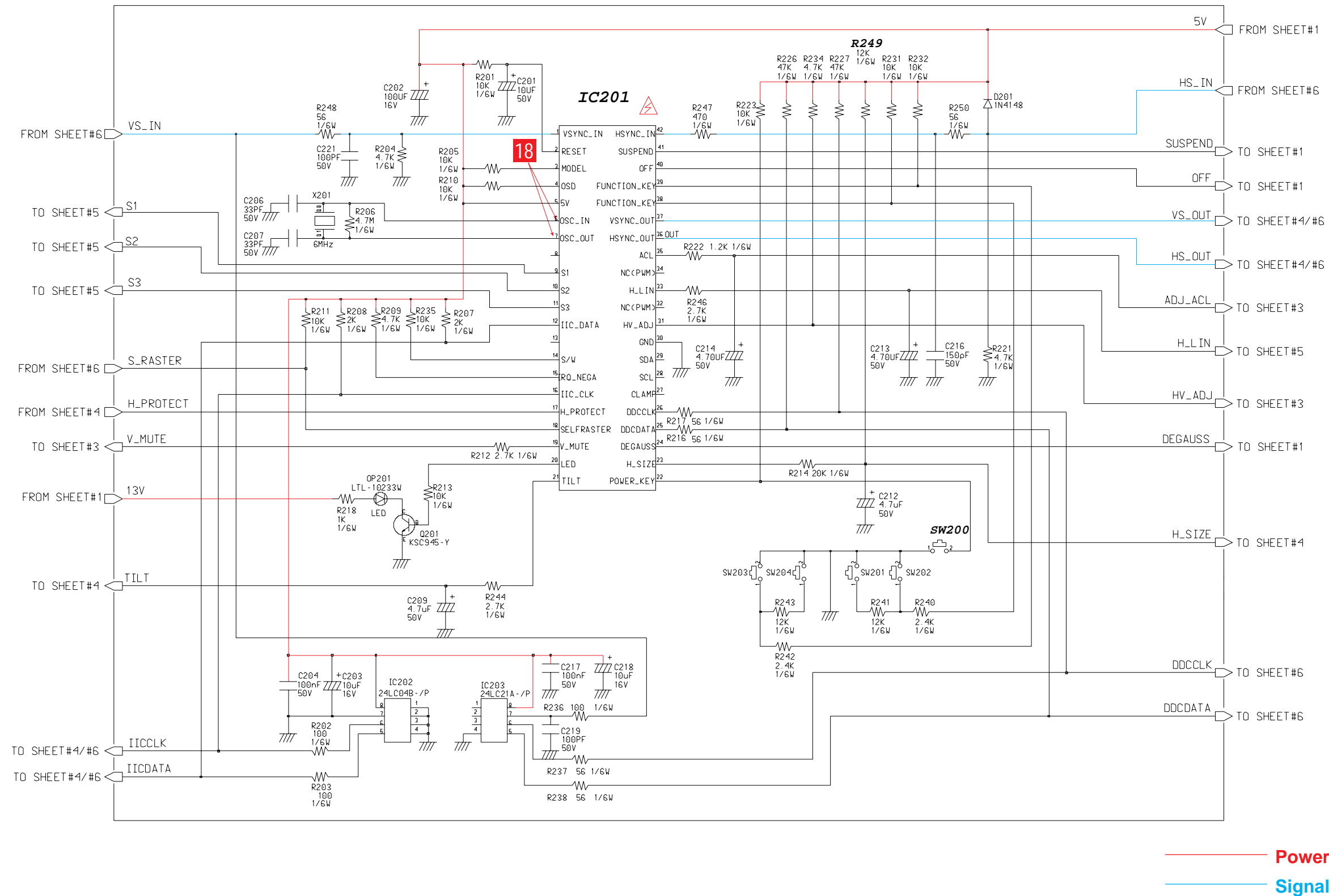
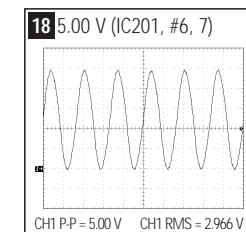

Table 13-2. IC201

pin #	MODES		pin #	MODES	
	800 x 600 / 85 Hz	640 x 480 / 60 Hz		800 x 600 / 85 Hz	640 x 480 / 60 Hz
1	4.370	4.706	22	5.079	5.081
2	5.080	5.079	23	2.511	4.054
3	-1.810 mV	-1.970 mV	24	4.700 mV	3.170 mV
4	5.080	5.080	25	3.633	3.635
5	5.085	5.085	26	3.517	3.519
6	2.450	2.450	27	NC	NC
7	2.123	2.121	28	NC	NC
8	NC	NC	29	NC	NC
9	14.53 mV	13.31	30	GND	GND
10	13.361	13.31	31	0.529	0.528
11	16.451 mV	13.31	32	NC	NC
12	5.084	5.090	33	3.998	5.035
13	NC	NC	34	NC	NC
14	-1.85 mV	-2.00 mV	35	3.837	3.840
15	5.066	5.067	36	4.751	4.465
16	5.084	5.085	37	8.430	6.310
17	-3.650 mV	-3.540 mV	38	5.079	5.082
18	52.28 mV	51.800 mV	39	5.079	5.082
19	10.02 mV	8.01 mV	40	5.031	5.034
20	5.039	5.042	41	5.073	5.076
21	1.629	1.630	42	0.298	4.334

Unit: Vrms



### 13-3 High Voltage Part Schematic Diagram

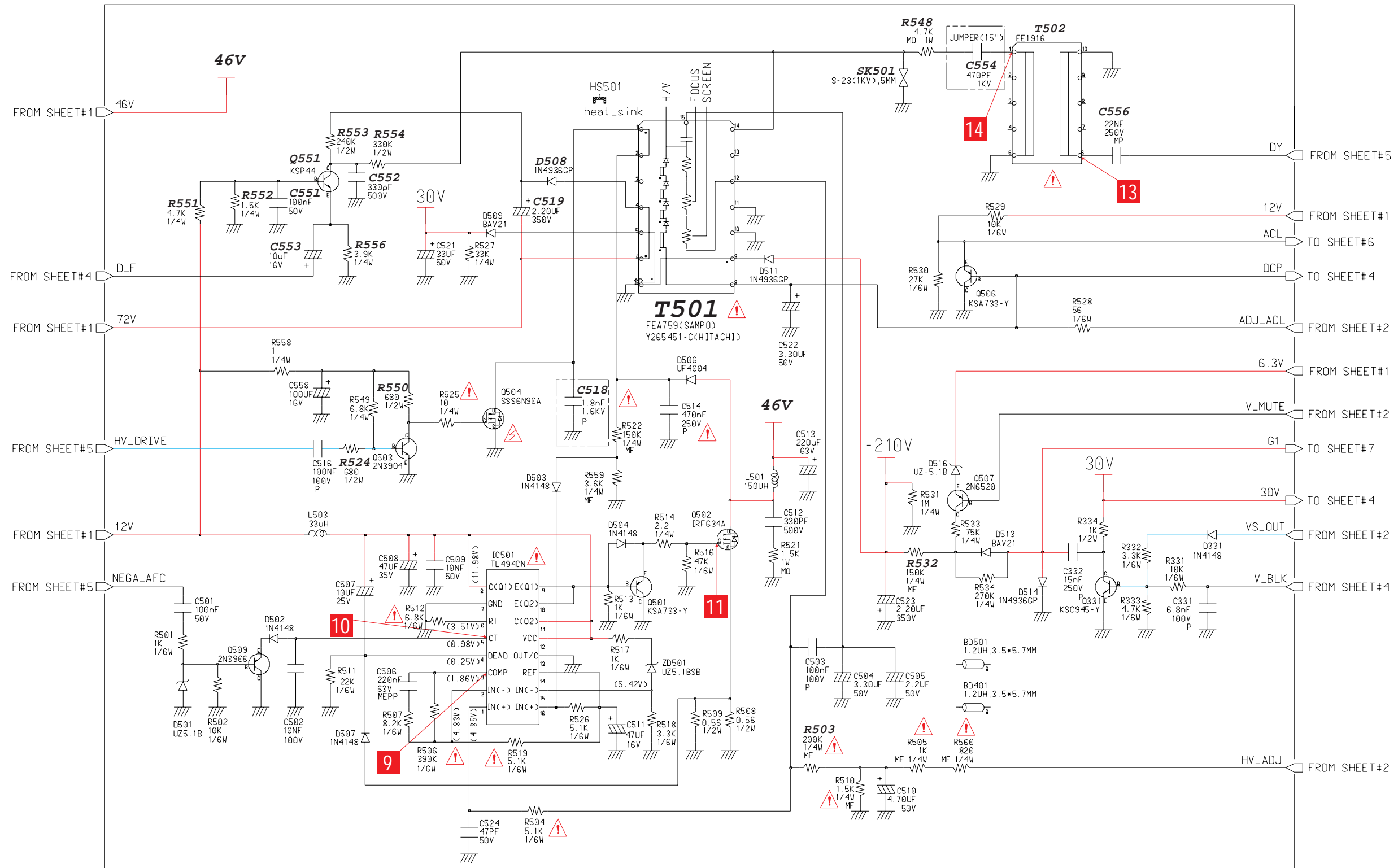

— Power Line  
— Signal Line

Table 13-3. IC501 (TL494CN)

pin #	MODES	
	800 x 600 / 85 Hz	640 x 480 / 60 Hz
1	4.859	4.868
2	4.855	4.867
3	1.753	2.471
4	21.80 mV	12.40 mV
5	0.910	1.245
6	3.485	3.485
7	GND	GND
8	11.834	11.836
9	3.035	1.458
10	3.034	1.458
11	11.834	11.836
12	11.834	11.836
13	GND	GND
14	4.896	4.896
15	5.334	5.336
16	4.901	4.895

Unit: Vrms

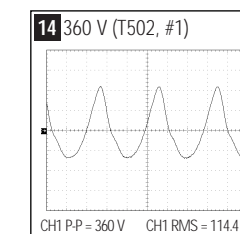
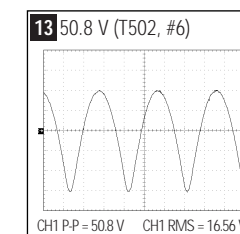
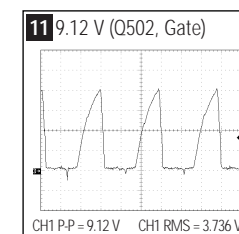
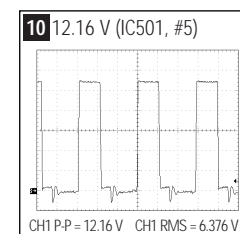
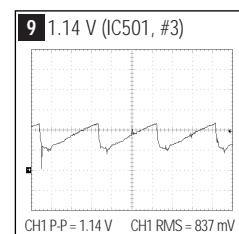

### 13-4 H/V OSC & Vertical Parts Schematic Diagram

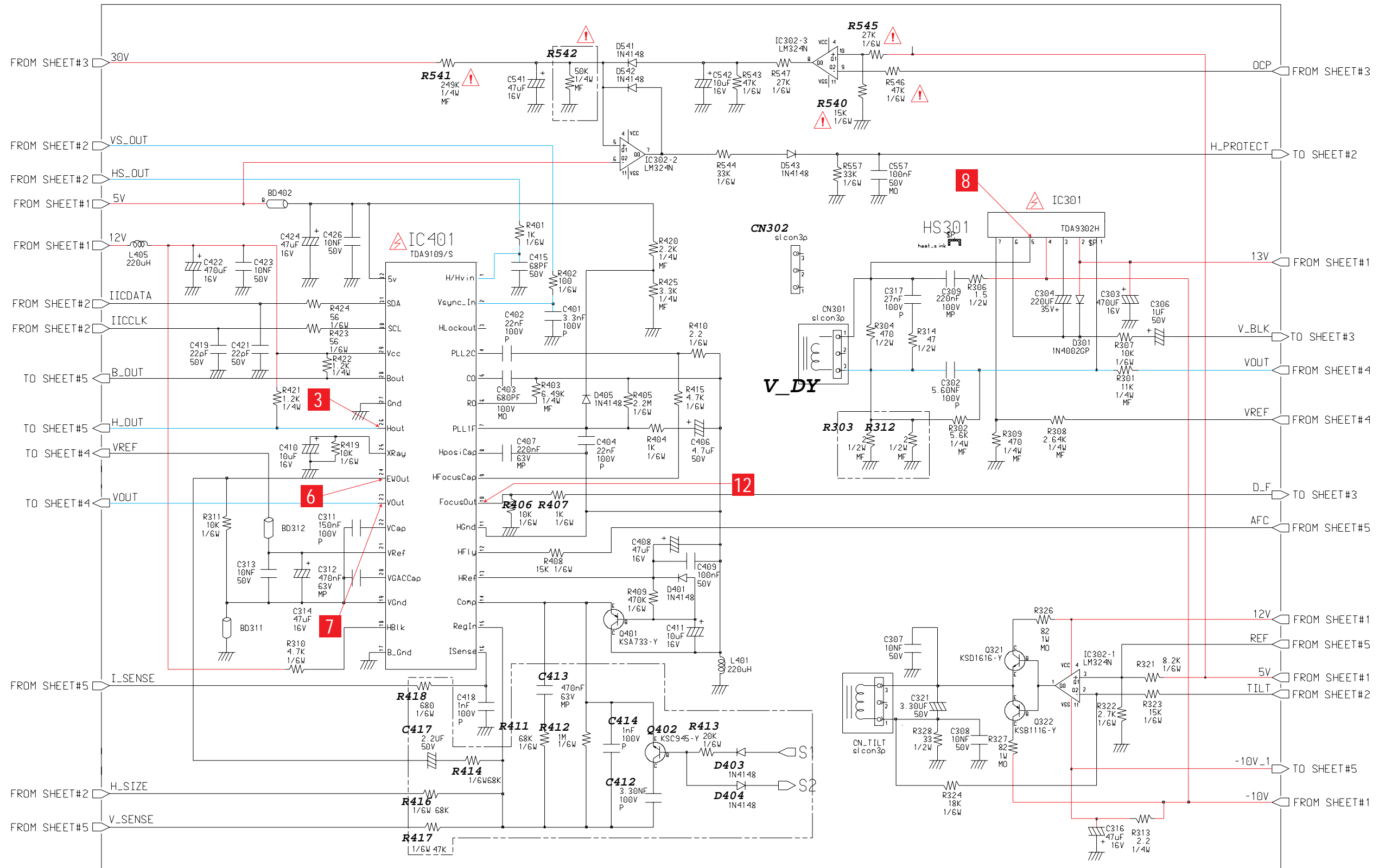

— Power Line  
 — Signal Line

Table 13-4. IC301 (TDA9302H)

pin #	MODES	
	800 x 600 / 85 Hz	640 x 480 / 60 Hz
1	1.221	1.223
2	13.368	13.314
3	-10.366	-10.435
4	-11.013	-10.913
5	-8.0 mV	-5.0 mV
6	13.111	12.936
7	1.225	1.225

Unit: Vrms

Table 13-5. IC302 (LM324N)

pin #	MODES	
	800 x 600 / 85 Hz	640 x 480 / 60 Hz
1	2.264	2.264
2	1.271	1.270
3	1.270	1.270
4	11.847	11.848
5	4.760	4.851
6	5.084	5.086
7	-10.894	-10.721
8	-10.307	-10.136
9	3.120	3.131
10	1.824	1.824
11	-10.888	-10.718
12	1.270	1.270
13	1.270	1.272
14	-2.616	-3.916

Unit: Vrms

Table 13-6 IC401 (TDA9109/S)

pin #	MODES		pin #	MODES	
	800 x 600 / 85 Hz	640 x 480 / 60 Hz		800 x 600 / 85 Hz	640 x 480 / 60 Hz
1	4.753	4.467	17	GND	GND
2	10.70 mV	8.50 mV	18	11.626	11.627
3	5.084	5.084	19	-0.220	-0.670
4	2.840	3.324	20	5.256	5.470
5	4.183	4.255	21	8.166	8.162
6	2.527	1.531	22	3.560	3.570
7	2.534	1.537	23	3.600	3.610
8	3.663	3.778	24	2.951	3.367
9	0.216	0.225	25	30.91 mV	31.97 mV
10	2.247	2.752	26	4.432	4.812
11	77.18 mV	73.60 mV	27	GND	GND
12	-0.367	-0.447	28	2.861	1.358
13	8.072	8.070	29	11.632	11.633
14	4.748	3.850	30	5.083	5.086
15	5.040	5.145	31	5.083	5.086
16	0.153	51.50 mV	32	5.084	5.087

Unit: Vrms

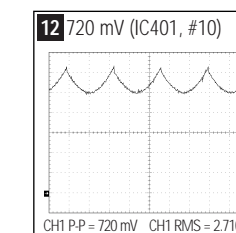
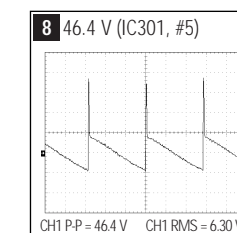
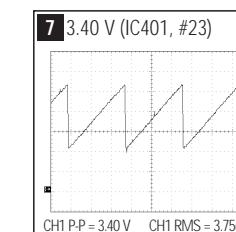
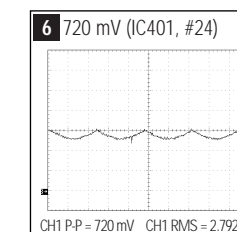
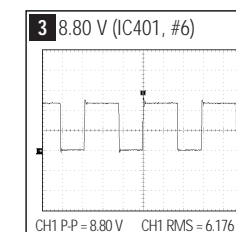



### 13-5 Horizontal Part Schematic Diagram

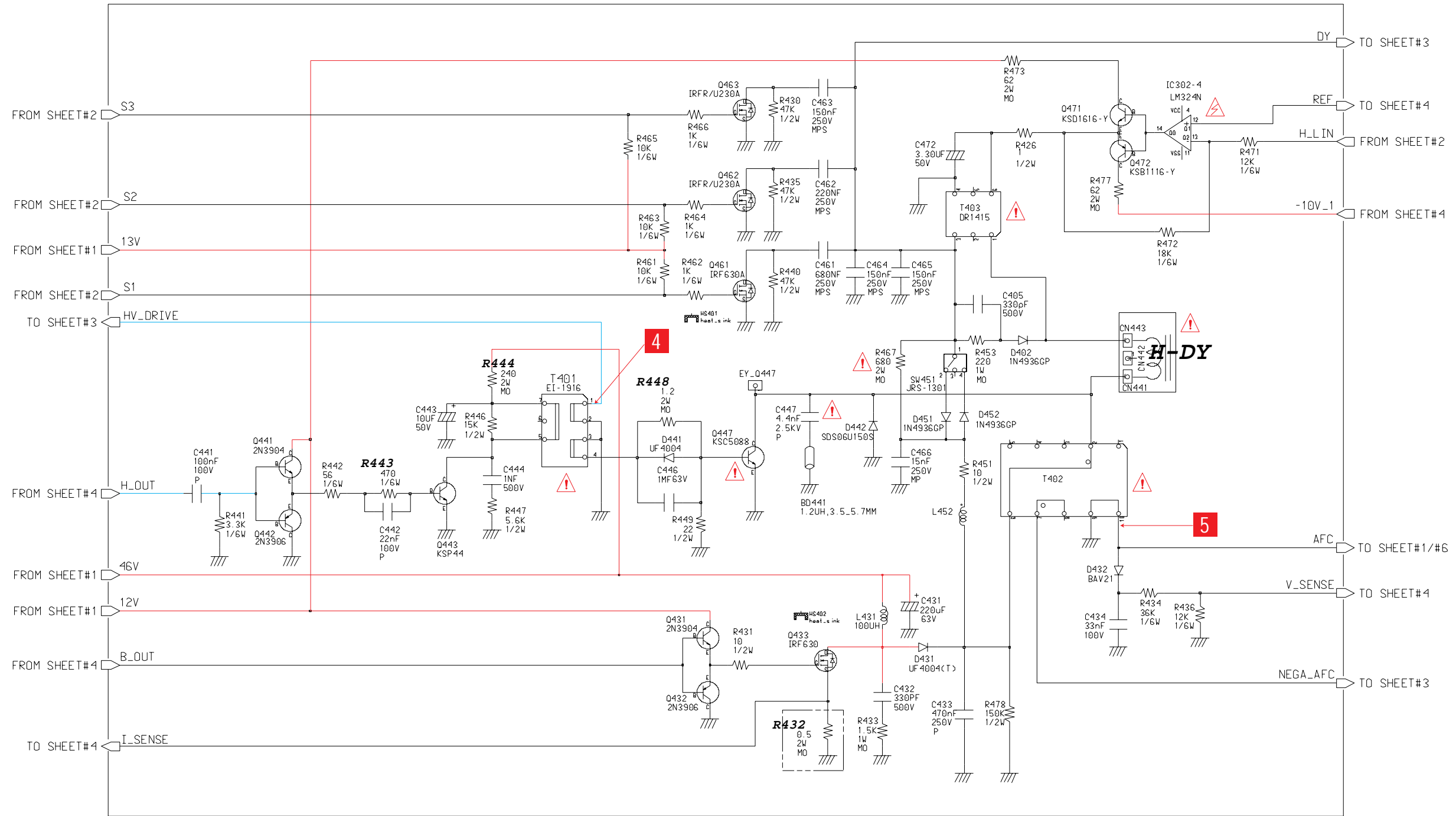

— Power Line  
— Signal Line

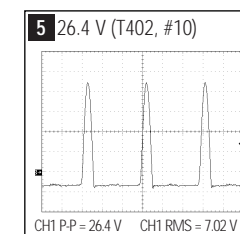
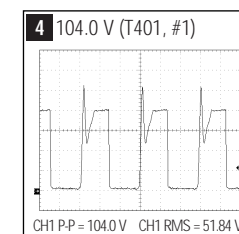

### 13-6 Video Part Schematic Diagram

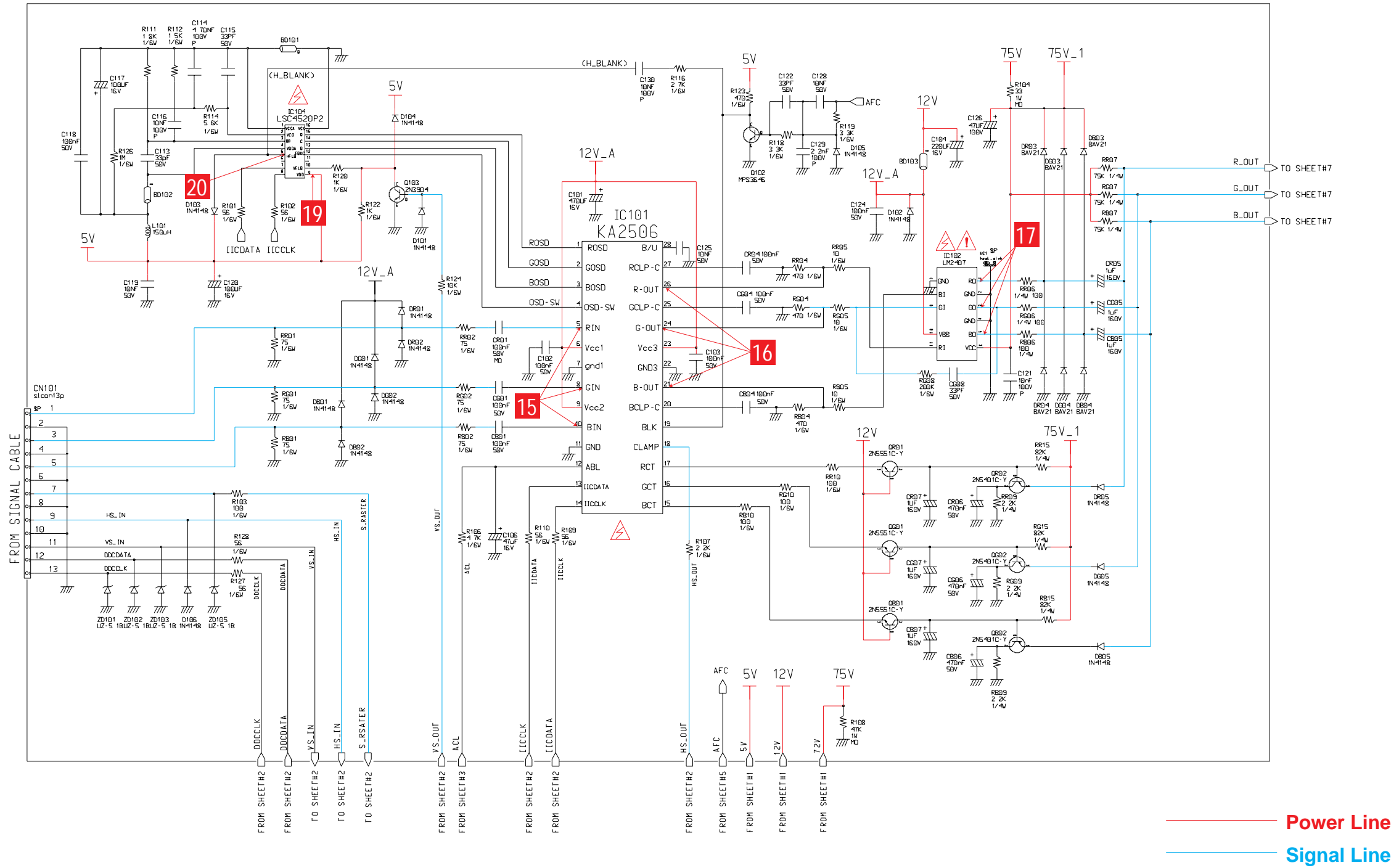

Table 13-7. IC101 (KA5606)

pin #	MODES		pin #	MODES	
	800 x 600 / 85 Hz	640 x 480 / 60 Hz		800 x 600 / 85 Hz	640 x 480 / 60 Hz
1	2.187	2.183	15	11.185	11.178
2	2.213	2.210	16	11.179	11.171
3	2.201	2.203	17	11.197	11.188
4	0.147	0.149	18	4.750	4.463
5	2.416	2.428	19	4.320	4.635
6	11.796	11.790	20	4.360	4.406
7	GND	GND	21	2.299	2.449
8	2.397	2.409	22	GND	GND
9	11.795	11.790	23	11.796	11.791
10	2.407	2.419	24	2.381	2.531
11	GND	GND	25	4.540	4.389
12	4.158	4.164	26	2.565	2.719
13	5.083	5.084	27	4.420	4.462
14	5.083	5.084	28	91.96 mV	92.85 mV

Unit: Vrms

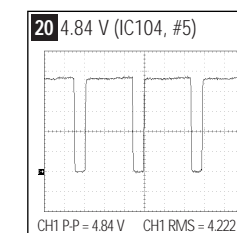
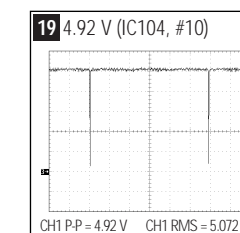
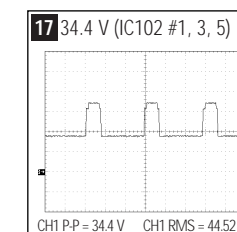
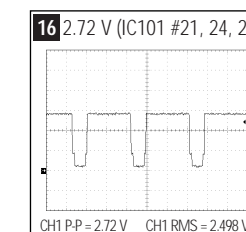
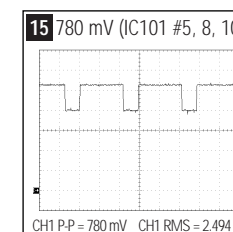

Table 13-8. IC102 (LM2407)

pin #	MODES	
	800 x 600 / 85 Hz	640 x 480 / 60 Hz
1	37.920	35.970
2	GND	GND
3	40.214	38.230
4	GND	GND
5	41.230	39.274
6	72.018	71.988
7	GND	GND
8	2.303	2.447
9	2.385	2.529
10	11.793	11.792
11	2.568	2.717

Unit: Vrms

Table 13-9. IC104 (LSC4520P2)

pin #	MODES	
	800 x 600 / 85 Hz	640 x 480 / 60 Hz
1	1.54 mV	1.74 mV
2	2.279	1.376
3	2.278	1.381
4	5.047	5.061
5	3.757	4.022
6	NC	NC
7	5.082	5.084
8	5.082	5.084
9	5.080	5.083
10	5.054	5.063
11	NC	NC
12	0.147	0.147
13	2.207	2.208
14	2.213	2.212
15	2.187	2.188
16	1.580 mV	1.870 mV

Unit: Vrms

13-7 CRT Part Schematic Diagram

