

Introduction

PM6680A evaluation kit order code: STEVAL-ISA053V2.

The PM6680A is a dual step-down controller with adjustable output voltages. The PM6680A evaluation kit is designed to test the performance of the PM6680A by employing a typical application circuit that allows testing of all the PM6680A device functions. The kit features two switching sections, with (typically) 3.3 V and 1.8 V outputs, from a 6 V to 36 V input voltage. The typical operating switching frequency of the two switching sections is 200 kHz / 300 kHz, respectively. Each switching section delivers more than 2.5 A of output current. Moreover, an internal linear regulator can provide 5 V @ 100 mA peak current.

Figure 1. PM6680A evaluation kit

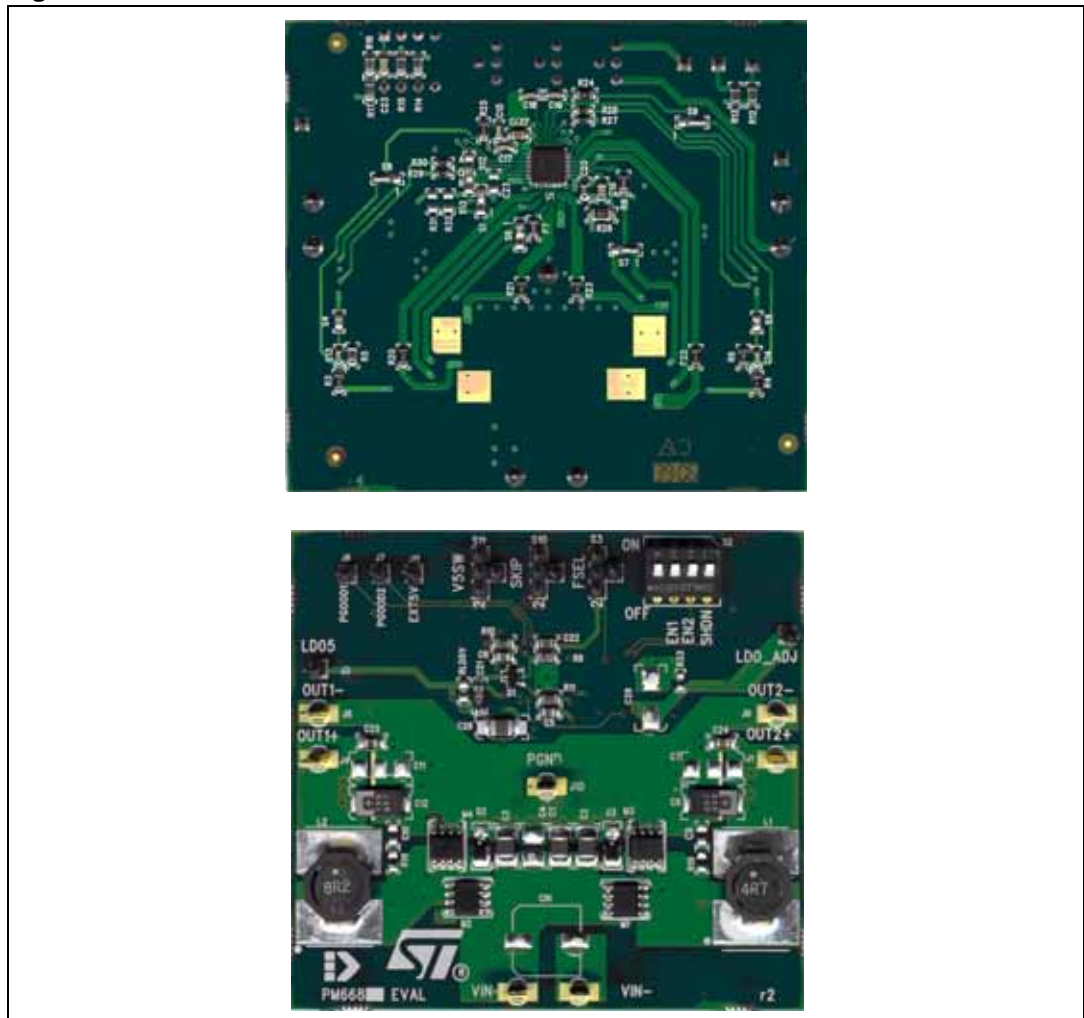

Contents

1	Main features	4
2	Evaluation kit schematic	5
3	Component list	6
4	Evaluation board layout	8
5	I/O interface	10
6	Recommended equipment	11
7	Quick start	12
8	Jumper settings	13
9	Feedback output connections	15
10	Test setup and performance summary	16
	10.1 Test setup	16
	10.2 Power-up	16
	10.3 Soft-start and shutdown waveforms	17
	10.4 OUT1 and OUT2 output efficiency vs. load current	19
	10.5 Power consumption analysis	20
	10.6 Switching frequency vs. load current	23
	10.7 Linear regulator output voltages vs. output current	24
	10.8 Load transient response	24
11	Representative waveforms	26
12	Revision history	28

List of figures

Figure 1.	PM6680A evaluation kit	1
Figure 2.	Evaluation kit schematic	5
Figure 3.	PM6680A eval board layout - top layer (PGND plane and component side)	8
Figure 4.	PM6680A eval board layout - inner layer 1 (SGND layer and V_{IN} plane)	8
Figure 5.	PM6680A eval board layout - inner layer 2 (SGND layer and signals)	9
Figure 6.	PM6680A eval board layout - bottom layer (PM6680A and component side)	9
Figure 7.	Test setup connections	16
Figure 8.	Power-up sequence	17
Figure 9.	Section 1 soft-start waveforms	17
Figure 10.	Section 2 soft-start waveforms	18
Figure 11.	Section 1 shutdown waveforms	18
Figure 12.	Section 2 shutdown waveforms	19
Figure 13.	OUT1 efficiency	20
Figure 14.	OUT2 efficiency	20
Figure 15.	Input current vs. input voltage.	21
Figure 16.	Input current vs. input voltage.	21
Figure 17.	Input current vs. input voltage.	22
Figure 18.	Device current consumption vs. input voltage	22
Figure 19.	Device current consumption vs. input voltage	23
Figure 20.	OUT1 switching frequency vs. load current	23
Figure 21.	OUT2 switching frequency vs. load current	24
Figure 22.	LDO5 output vs. load current	24
Figure 23.	OUT1 load transient response	25
Figure 24.	OUT2 load transient response	25
Figure 25.	SMPS pulse skip mode.	26
Figure 26.	SMPS no-audible skip mode	26
Figure 27.	SMPS PWM mode	27

1 Main features

- Constant on-time control allows very fast load transients
- 6 V to 36 V input voltage range
- 5 V auxiliary output voltage
- Adjustable switching outputs
- Lossless current sensing using low side MOSFET $R_{DS(on)}$
- Negative current limit
- Soft-start internally fixed at 2.8 ms
- Soft-end for output discharge
- 200 kHz / 300 kHz, 300 kHz / 400 kHz, 400 kHz / 500 kHz (OUT1 / OUT2 selectable switching frequency)
- Selectable pulse skip and no-audible skip modes at light loads
- Independent power good signals

2 Evaluation kit schematic

Figure 2. Evaluation kit schematic

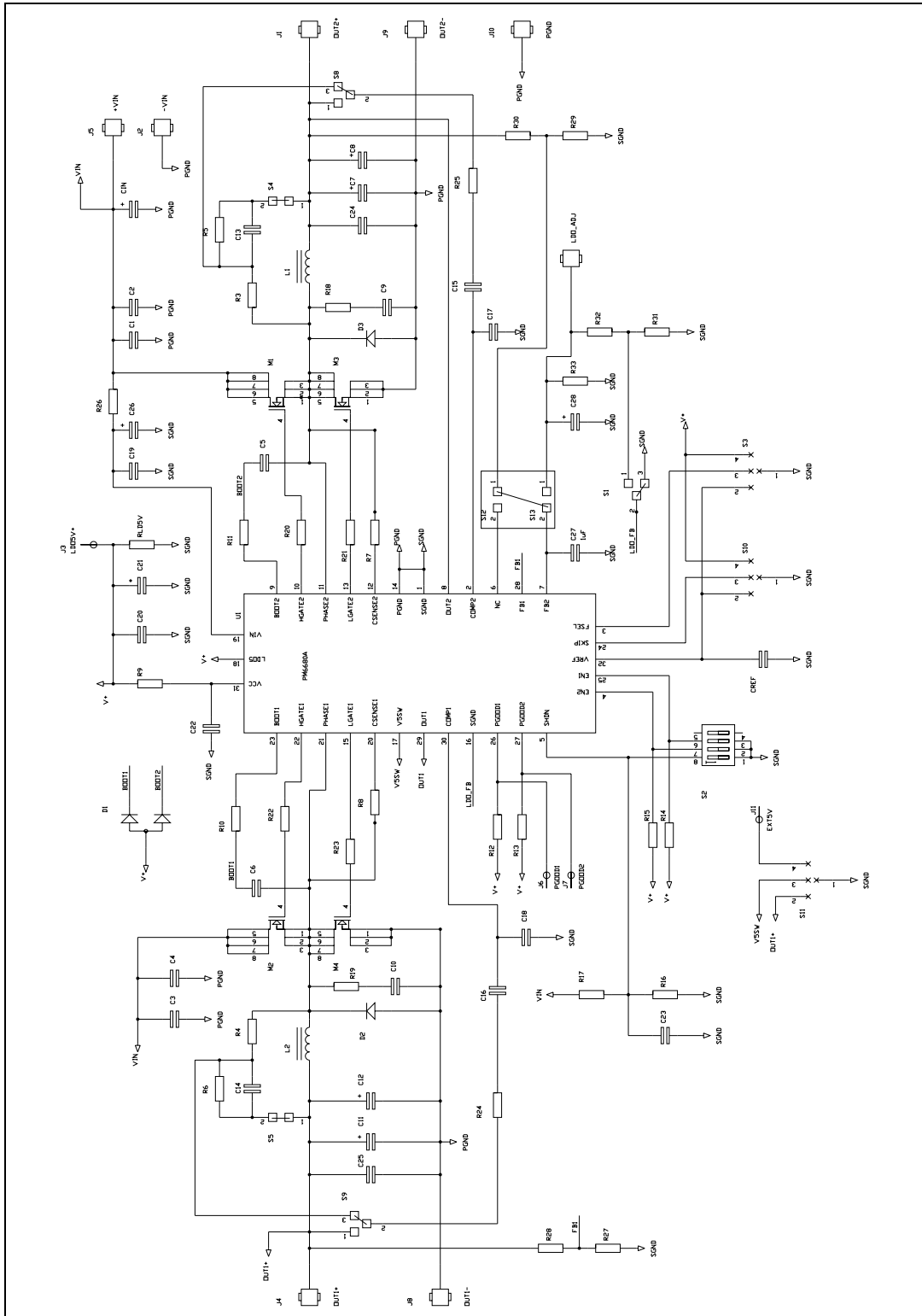

3 Component list

Table 1. Component list

Qty	Reference	Description	Value	Package	Part number
3	C1, C2, C3	Ceramic capacitor	10 μ F, 50 V	1210	Taiyo Yuden - UMK325BJ106KM
1	C4	Ceramic capacitor	10 μ F, 50 V	1210	
2	C5, C6	Ceramic capacitor	100 nF, 50 V	0805	
1	C19	Ceramic capacitor	100 nF, 50 V	0805	
1	C7	Tantalum capacitor	N.M.	7343	N.M.
2	C9, C10	Ceramic capacitor	N.M.	0805	N.M.
1	C11	Tantalum capacitor	N.M.	7343	N.M.
1	C8	Tantalum capacitor	220 μ F, 25 m Ω , 6.3 V	7343	Sanyo POSCAP - 6TPE220M
1	C12	Tantalum capacitor	150 μ F, 18 m Ω , 4 V	7343	Sanyo POSCAP - 4TPE150MI
2	C13, C14	Ceramic capacitor	10 nF, 50 V	0603	
2	C15, C16	Ceramic capacitor	1.5 nF, 50 V	0603	
2	C17, C18	Ceramic capacitor	47 pF, 50 V	0603	
1	C20	Ceramic capacitor	1 μ F, 10 V	0805	
1	C21	Tantalum capacitor	4.7 μ F, 16 V	3216	
1	C22	Ceramic capacitor	220 nF, 10 V	0805	
1	C23	Ceramic capacitor	10 pF, 50 V	0805	
1	CIN	Tantalum capacitor	N.M.	D = 10 mm	
1	CREF	Ceramic capacitor	100 nF, 50 V	0805	
1	C26	Ceramic capacitor	4.7 μ F, 50 V	1210	Taiyo-Yuden - UMK325F475ZH
1	C24, C25	Ceramic capacitor	10 μ F, 6.3 V	0805	
1	C27	Tantalum capacitor	N.M.	0805	
1	C28	Tantalum capacitor	N.M.	3216	
1	D1	Dual Schottky diode		SOT23	ST - BAS70
2	D2, D3	Power Schottky rectifier		SMA	STPS1L30M
1	IC1	PM6680A		VFQFPN-32 5x5	ST - PM6680A
1	L1	Power inductor	4.7 μ H, 4 A	10 mm x 10 mm	Würth - TPC 7440650047
1	L2	Power inductor	8.2 μ H, 3 A	10 mm x 10 mm	Würth - TPC 7440650082
4	M1, M2	>40 V N-channel MOSFET		SO-8	ST - STS5NF60L

Table 1. Component list (continued)

Qty	Reference	Description	Value	Package	Part number
4	M3, M4	> 40 V N-channel MOSFET		SO-8	ST - STS7NF60L
1	R3	Resistor 1%	20 k Ω	0805	
1	R4	Resistor 1%	47 k Ω	0805	
1	R5	Resistor 1%	2.2 k Ω	0805	
1	R6	Resistor 1%	1.1 k Ω	0805	
2	R7, R8	Resistor 1%	390 Ω	0805	
1	R9	Resistor 1%	47 Ω	0805	
2	R10, R11	Resistor 1%	10 Ω	0805	
4	R12:R15	Resistor 1%	100 k Ω	0805	
1	R16	Resistor 1%	43 k Ω	0805	
1	R17	Resistor 1%	510 k Ω	0805	
2	R18, R19	Resistor 1%	N.M.	0805	
4	R20, R21, R22, R23	Resistor 1%	0 Ω	0805	
1	R24	Resistor 1%	1.1 k Ω	0805	
1	R25	Resistor 1%	820 Ω	0805	
1	R26	Resistor 1%	3.9 Ω	1206	
1	R27	Resistor 1%	10 k Ω	0805	
1	R29	Resistor 1%	10 k Ω	0805	
1	R28	Resistor 1%	27 k Ω	0805	
1	R30	Resistor 1%	10 k Ω	0805	
1	R31	Resistor 1%	N.M.	0603	
1	R32	Resistor 1%	N.M.	0603	
1	R33	Resistor 1%	N.M.	0805	
1	RLD5V, RLD3V	Resistor	N.M.	0805	

4 Evaluation board layout

Figure 3. PM6680A eval board layout - top layer (PGND plane and component side)

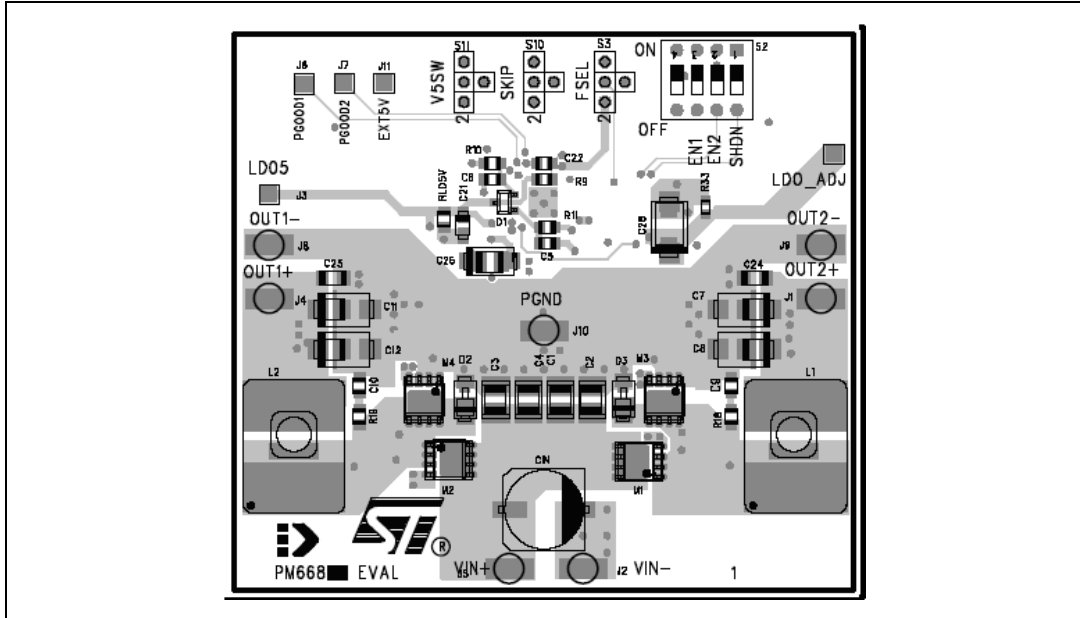

Figure 4. PM6680A eval board layout - inner layer 1 (SGND layer and V_{IN} plane)

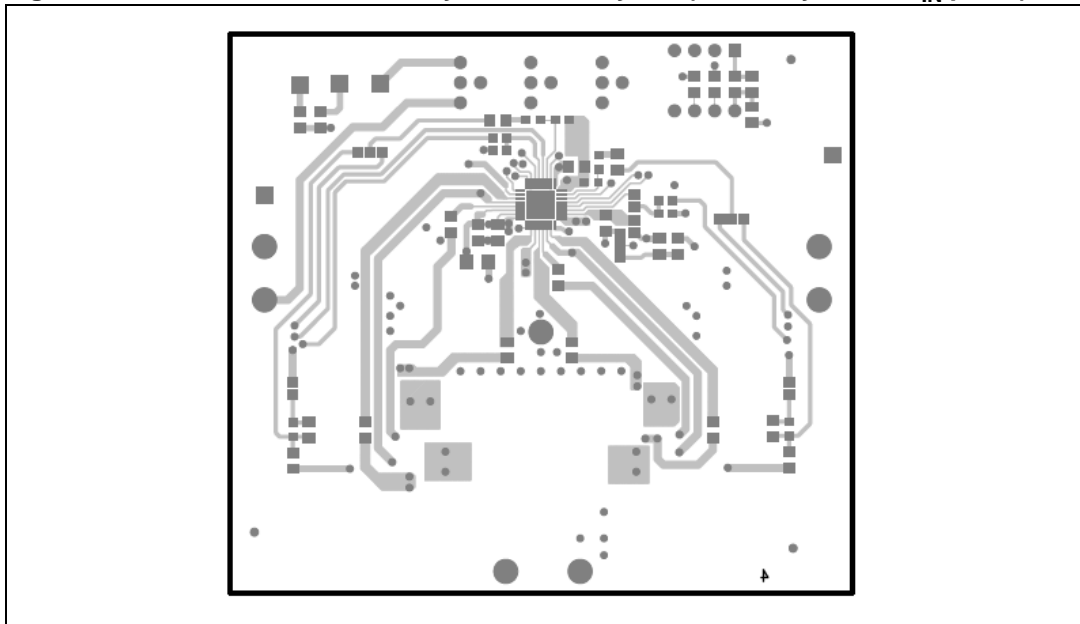

Figure 5. PM6680A eval board layout - inner layer 2 (SGND layer and signals)

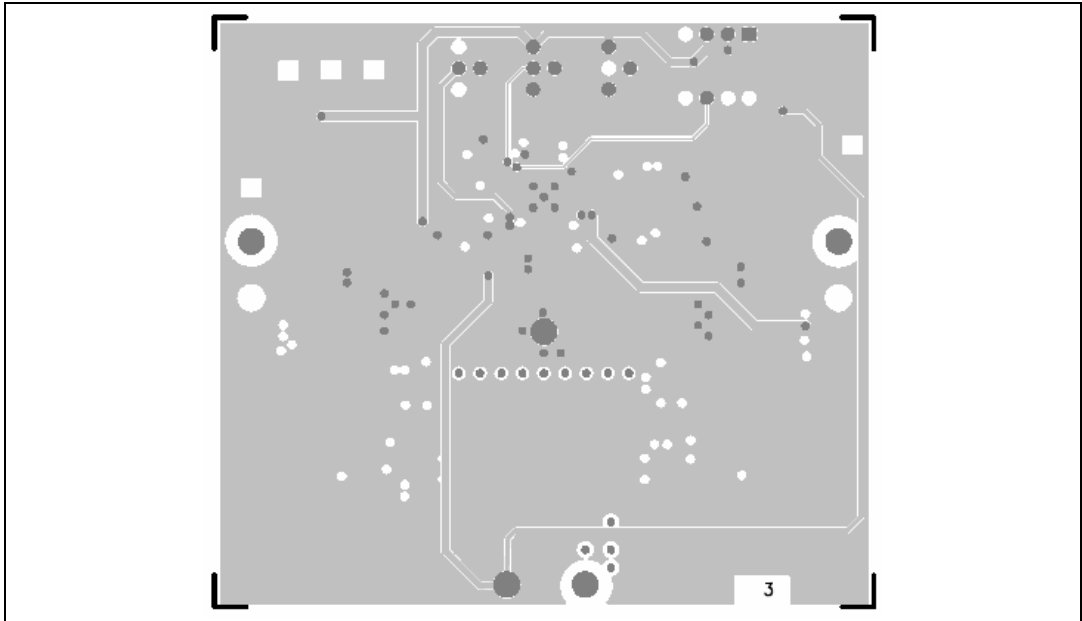
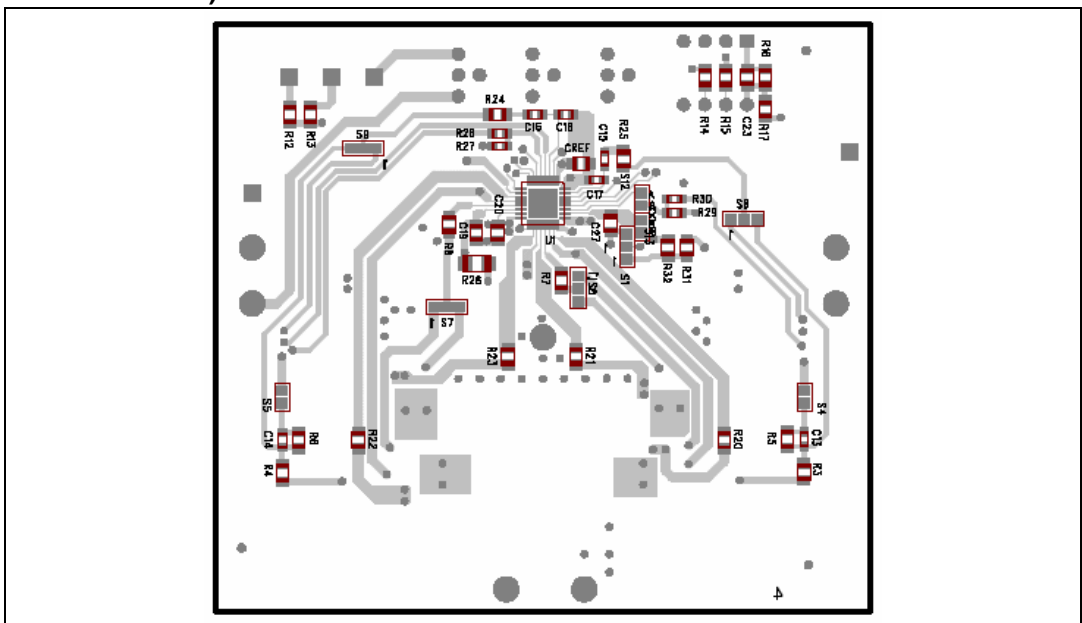

Figure 6. PM6680A eval board layout - bottom layer (PM6680A and component side)



5 I/O interface

The evaluation board has the following test points.

Table 2. Test points of the evaluation board

Test point	Description
V _{IN+}	Input voltage
V _{IN-}	Input voltage ground
LDO5	5 V linear regulator output
LDO_ADJ	Not used for this device
EXT5V	5 V external input
OUT1+	OUT1 switching section output
OUT1-	OUT1 switching section output ground
PGOOD1	OUT1 switching section power good
OUT2+	OUT2 switching section output
OUT2-	OUT2 switching section output ground
PGOOD2	OUT2 switching section power good
J10	Junction pin between PGND and SGND planes

6 Recommended equipment

- 6 V to 36 V power supply, notebook computer battery or AC adapter
- Active loads
- Digital multimeter
- 500 MHz four-trace oscilloscope

7 Quick start

1. Connect the V_{IN+} and V_{IN-} test points of the evaluation board to an external power supply.
2. Ensure that all DIP switches (S2) are in the "OFF" position. In this condition all outputs are disabled (shutdown mode).
3. Move switch $S2_1$ to the "ON" position (SHDN pin high). This turns on the LDO5 output (standby mode).
4. Move switch $S2_2$ to the "ON" position (EN1 pin high). The 1.5 V switching controller begins regulation of the output. PGOOD1 pin goes high after soft-start.
5. Move switch $S2_3$ to the "ON" position (EN2 pin high). The 1.05 V switching controller begins regulation of the output. PGOOD2 pin goes high after soft-start.
6. In order to load the switching outputs, the loads must be connected between the "+" and the "-" output test points, respectively.
7. In order to load the linear outputs, the loads must be connected between J10 and LDO5 or alternative RLD5V resistors can be used on the evaluation board.



8 Jumper settings

It is possible to select different working conditions by using the jumpers on the board.

Note: Jumpers S1, S12 and S13 are already soldered on the evaluation board and it is not necessary to change them. Please refer to the schematic to verify their proper connection.



The external bypass connections for the linear regulator LDO5 are set by connecting the V5SW pin to jumper S11 as indicated in [Table 3](#) below.

Table 3. Jumper S11 - V5SW pin connections

Position	LDO5 working conditions
OUT5V 	When the main output voltage is greater than the bootstrap-switchover threshold, an internal 3 Ω (max) P-channel MOSFET switch connects the V5SW pin to the LDO5 pin, shutting down the LDO5 internal linear regulator. If not used, it must be tied to ground.
SGND 	The internal linear regulator LDO5 is always on. In this case, LDO5 supplies all gate drivers and the internal circuitry. It can provide an output peak current of 100 mA.
EXT5V 	The internal linear regulator LDO5 remains off if an alternative 5 V external voltage is applied to the EXT5V test point. An internal 3 Ω (max) P-channel MOSFET switch connects the V5SW pin to the LDO5 output. The gate drivers and internal circuitry are supplied by the same 5 V external voltage applied.



The FSEL pin is connected to jumper S3 to select the SMPS frequency. The jumper positions and corresponding frequencies are shown in [Table 4](#) below.

Table 4. Jumper S3 - FSEL pin connections

Position	SMPS OUT1	SMPS OUT2
SGND 	200 kHz	300 kHz
VREF 	300 kHz	400 kHz
LDO5 	400 kHz	500 kHz

To select the switching operation mode of the SMPS, connect the SKIP pin to jumper S10 as described in [Table 5](#).

Table 5. Jumper S10 - SKIP pin connections

Position	Switching operating mode
<p>GND</p> 	<p>If the SKIP pin is tied to ground, a pulse skip mode takes place at light loads. A zero crossing comparator prevents the inductor current from going negative.</p>
<p>VREF</p> 	<p>If the SKIP pin is tied to VREF pin enables a pulse skip mode with a minimum switching frequency about 25 kHz (ultrasonic mode).</p>
<p>LDO5</p> 	<p>If the SKIP pin is tied to 5 V, The fixed PWM mode takes place. The switching output is in a position to sink and source current from the load.</p>

9 Feedback output connections

[Table 6](#) and [Table 7](#) below illustrate jumper settings for a loop compensation network for very low output voltage ripple.

Table 6. Jumper S4, S5

Position	Output ripple compensation
Short	Virtual ESR output ripple is generated by using a compensation network connected between the output and the PHASE pin of the switching section.

Table 7. Jumper S8, S9

Position	Feedback connection
	Controller feedback signal connected to the compensation network

[Table 8](#) and [Table 9](#) describe the settings for a loop compensation network for high output voltage ripple.

Table 8. Jumper S4, S5

Position	Output ripple compensation
Open	ESR output ripple is used.

Table 9. Jumper S8, S9

Position	Feedback connection
	Controller feedback signal connected directly to the output capacitor.

10 Test setup and performance summary

10.1 Test setup

The PM6680A evaluation board has the following input/output connections:

- 24 V input through J5-J2 (V_{IN+} and V_{IN-})
- 3.3 V SMPS output through J4-J13 (OUT1+ and OUT1-)
- 1.8 V SMPS output through J1-J12 (OUT2+ and OUT2-)
- 5 V linear regulator output through J3 (LDO5)

Figure 7. Test setup connections

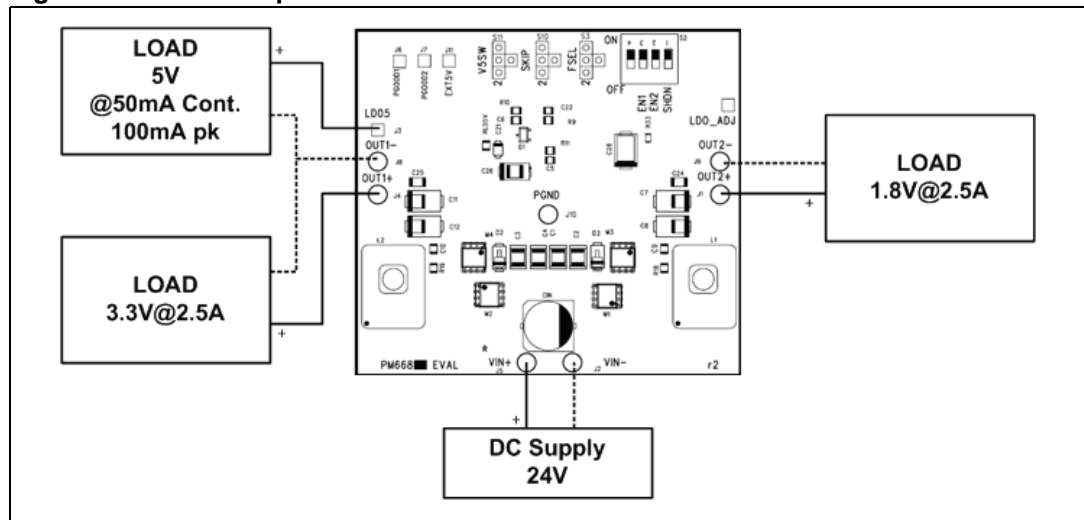

A power supply capable of supplying at least 6 A should be connected to V_{IN+} , V_{IN-} , and two active loads should be connected respectively to OUT1+, OUT1- and OUT2+, OUT2-.

10.2 Power-up

As shown in [Figure 8](#), the power-up starts when the input voltage is applied and the voltage on the SHDN pin is above the device “on” threshold. First, the LDO5 goes up with a masking time of about 4 ms.

Figure 8. Power-up sequence

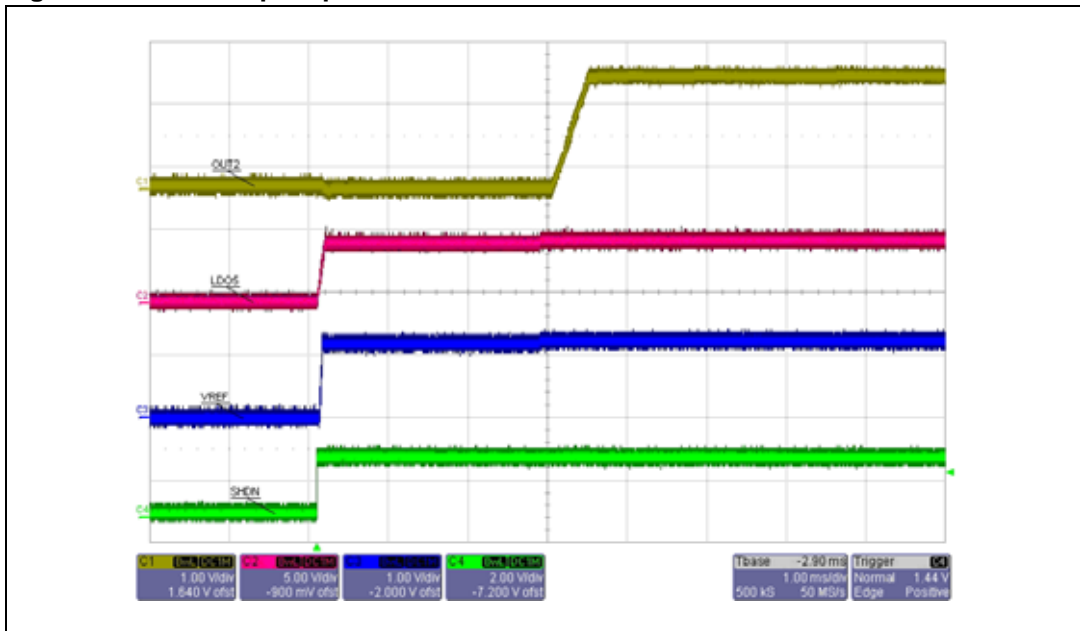

10.3 Soft-start and shutdown waveforms

Figures 9 and 10, and figures 11 and 12 show the soft-start and shutdown waveforms, respectively.

The PM6680A has an independent internal digital soft-start for each switching section. During the soft-start phase the internal current limit increases from 25% to 100%, in increments of 25%, to avoid the inductor current reaching too high a value.

Figure 9. Section 1 soft-start waveforms

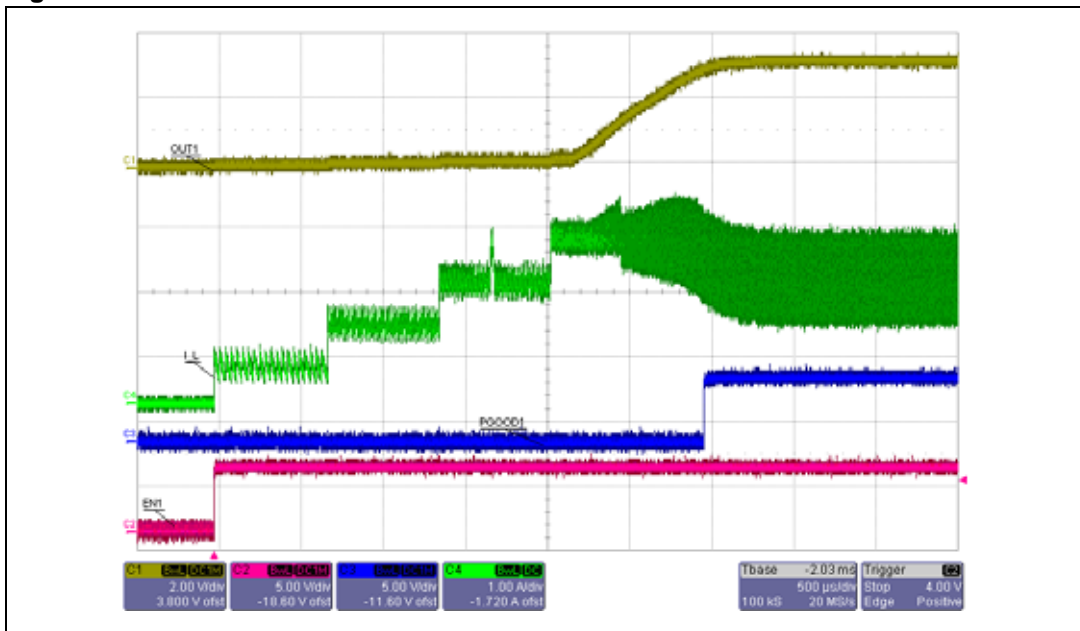
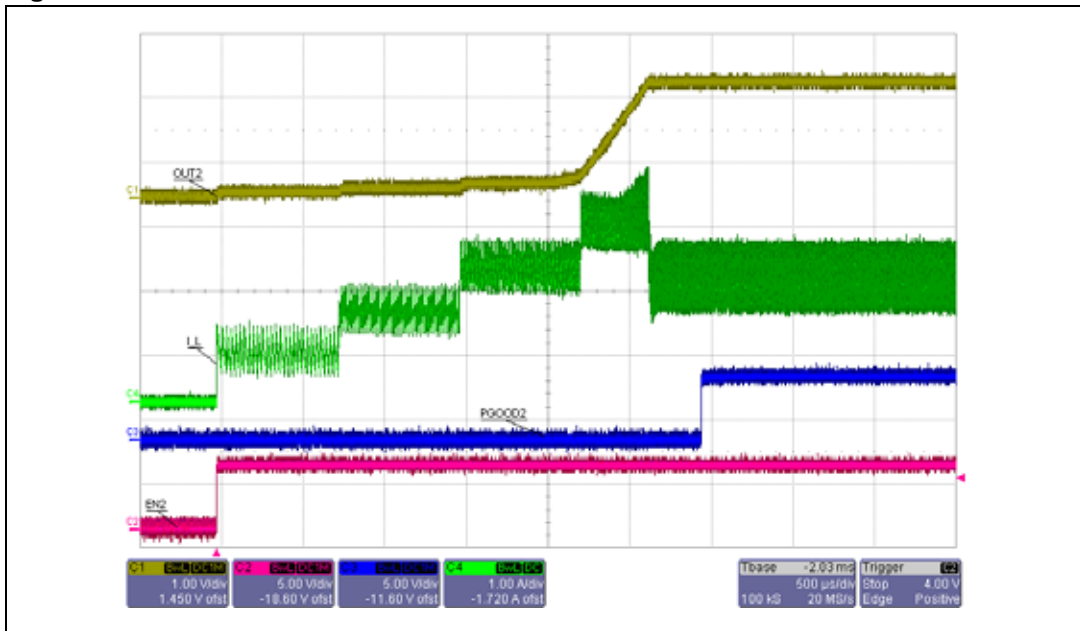

Figure 10. Section 2 soft-start waveforms



Driving the SHDN pin below the SHDN device “off” threshold will cause the device to enter shutdown mode. In this case the switching outputs are connected to ground through an internal 12 Ω power MOSFET and are discharged softly, (discharge mode). When the output voltages reach 0.3 V, the low side MOSFETs are turned on, quickly discharging them to ground.

Figure 11. Section 1 shutdown waveforms

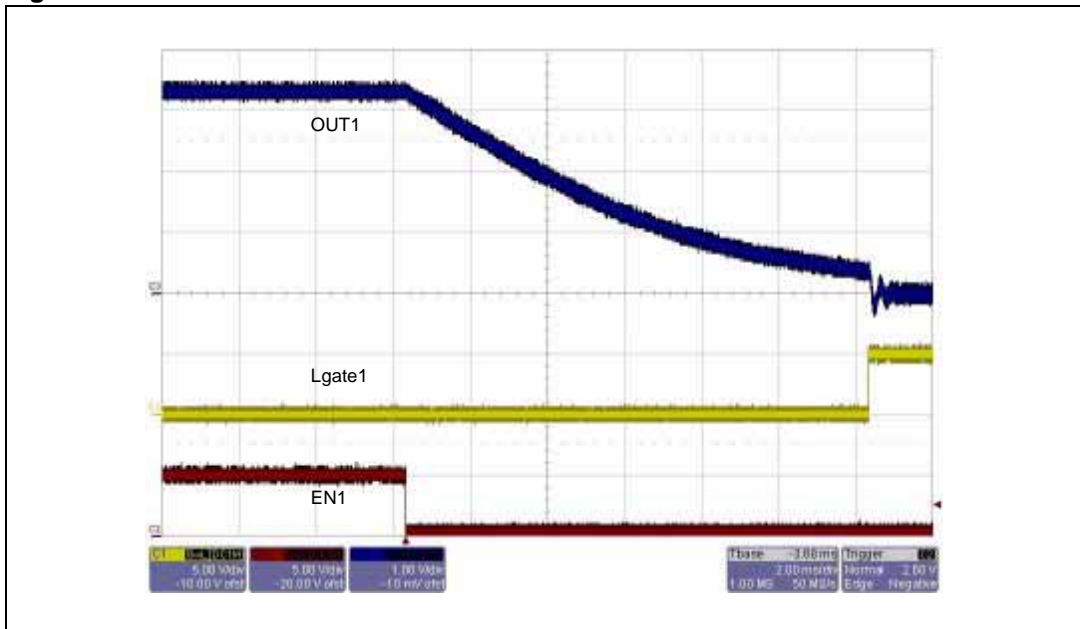
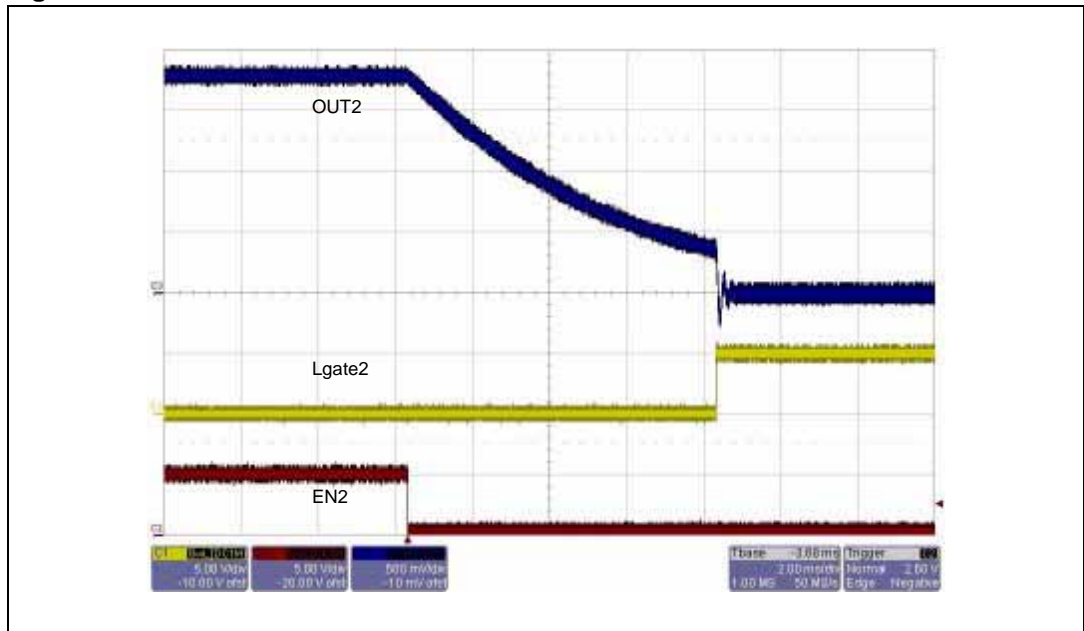

Figure 12. Section 2 shutdown waveforms



10.4 OUT1 and OUT2 output efficiency vs. load current

Figure 13 and *Figure 14* show the efficiency versus load current for different input voltage values in PWM mode, skip mode and no audible skip mode.

Figure 13. OUT1 efficiency

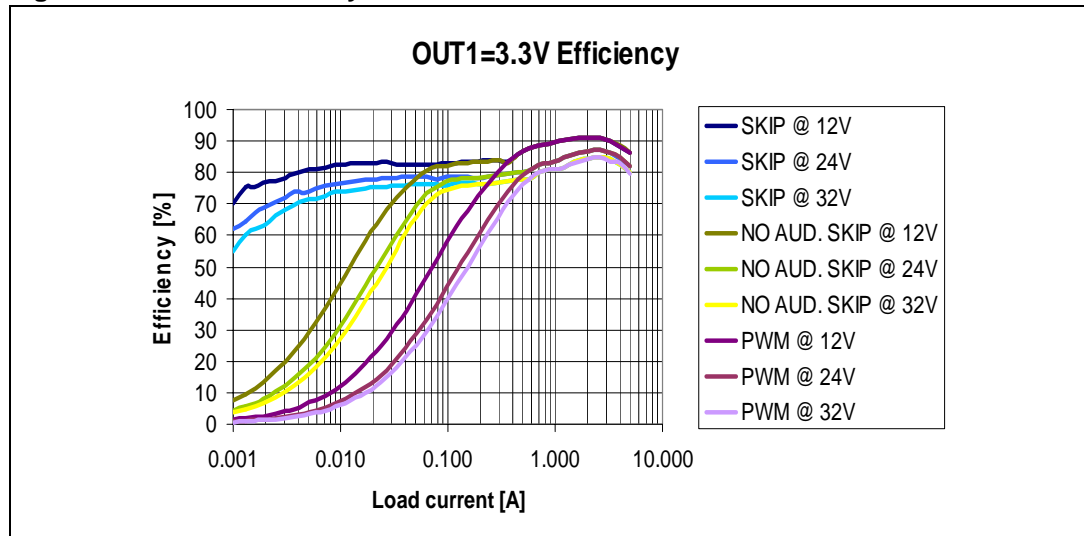
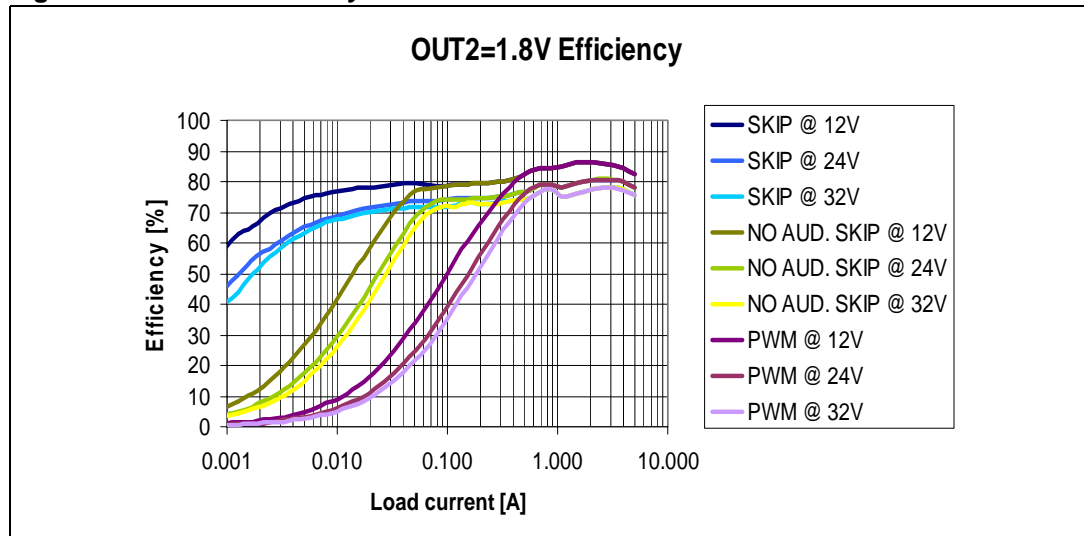

Figure 14. OUT2 efficiency



10.5 Power consumption analysis

To measure the device consumption under real working conditions, an external power supply of +5 V is connected to EXT5V.

The two traces on figures that follow show the differentiation between the two input currents. Once the internal linear regulator is turned on, device consumption will increase as a consequence.

Figure 15 shows the input current consumption measured at V_{IN+} (including ISHDN) and the input device current consumption measured at the VCC pin. Both switching sections are working in forced PWM mode. No load is applied on the outputs.

Figure 15. Input current vs. input voltage

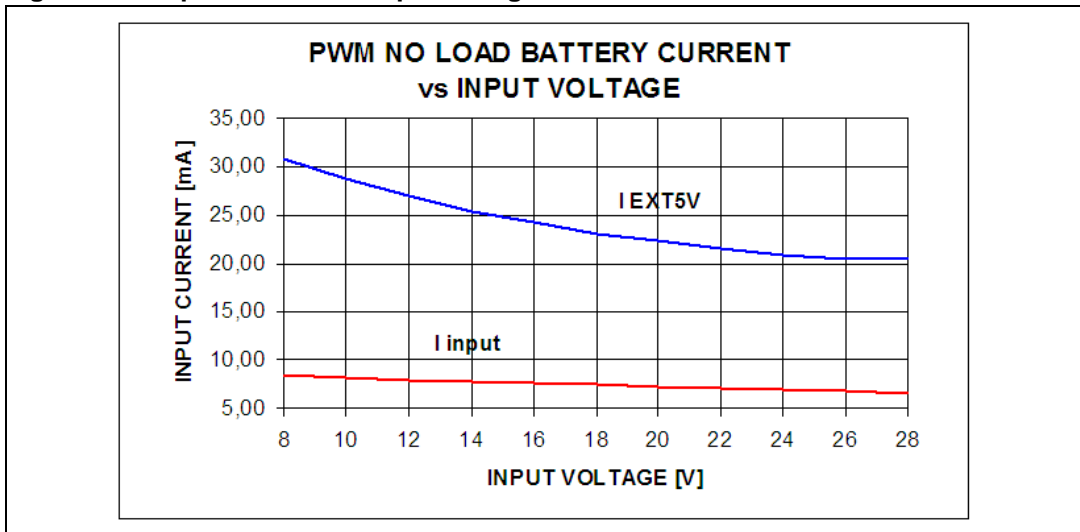

Figure 16 shows the input current measured at VIN+(includes ISHDN) and the input device current consumption measured at the VCC pin (I_EXT5V). Both switching sections are working in SKIP mode. No load is applied.

Figure 16. Input current vs. input voltage

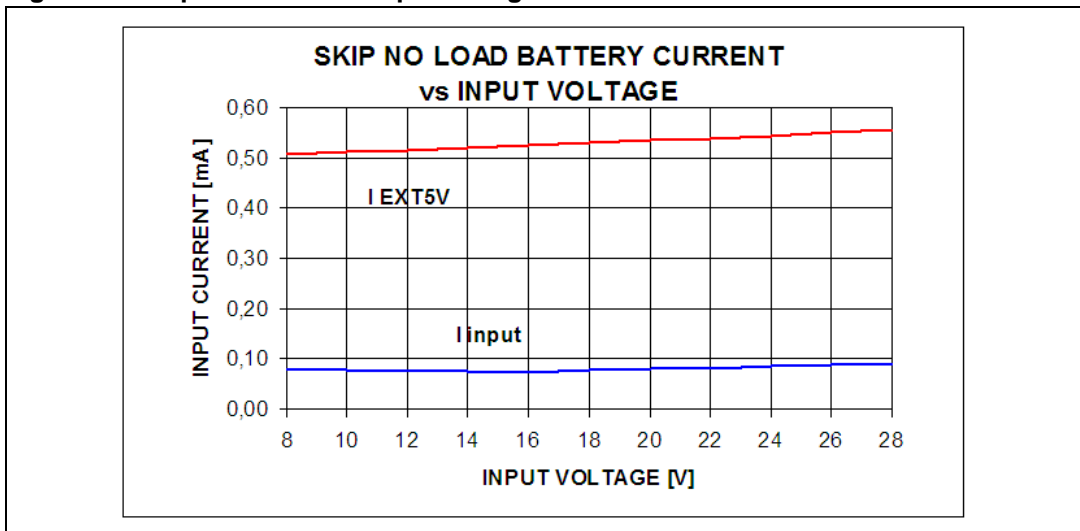
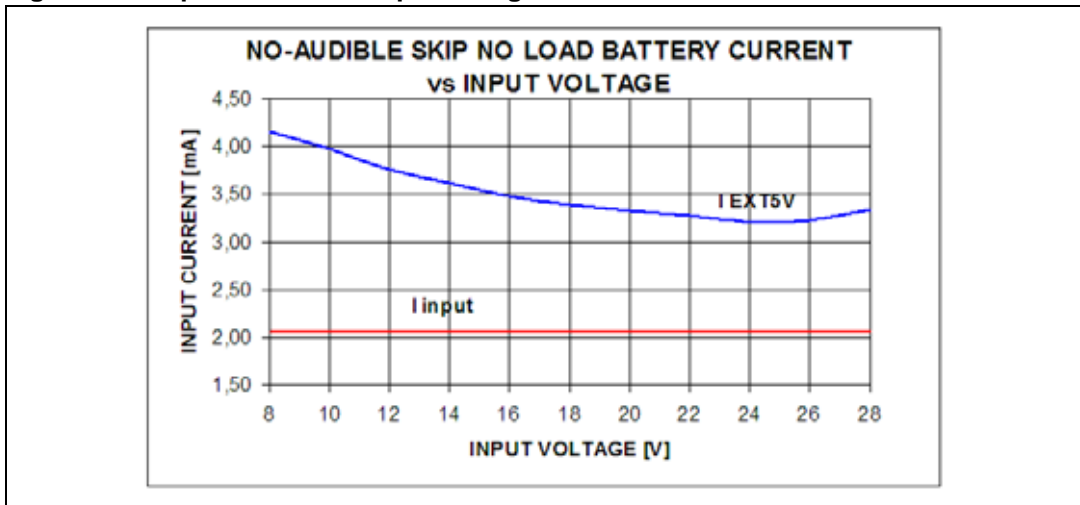

Figure 17 shows the input current measured at VIN+(includes ISHDN) and the input device current consumption measured at the VCC pin (I_EXT5V). Both switching sections are working in NO-AUDIBLE SKIP mode. No load is applied.

Figure 17. Input current vs. input voltage



In the following illustrations, the device current consumption is measured in shutdown mode and standby mode. In shutdown mode all outputs are off (SHDN pin low). In standby mode only the linear regulator output is on (V5SW = SGND, SHDN pin high, EN5 and EN3 pins low).

Figure 18. Device current consumption vs. input voltage

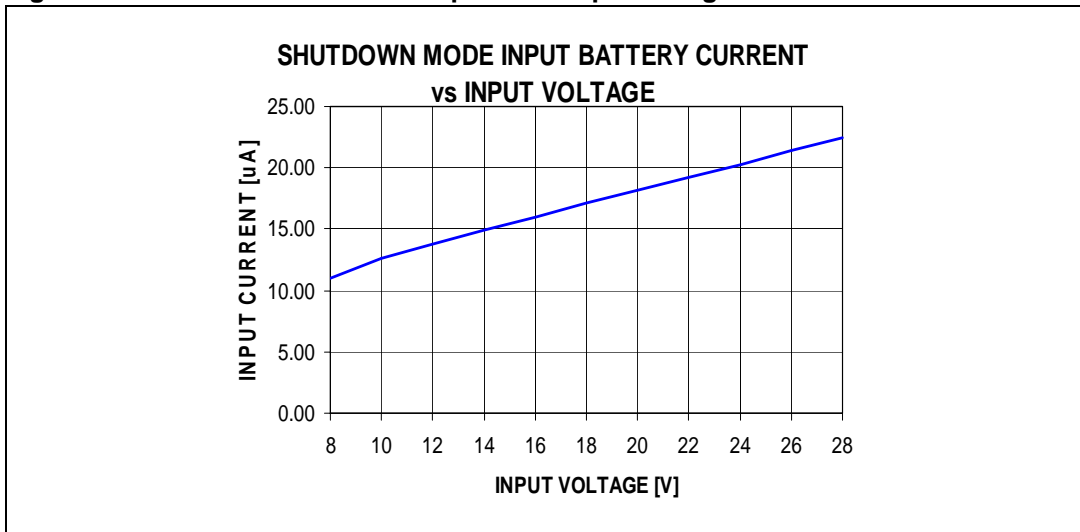
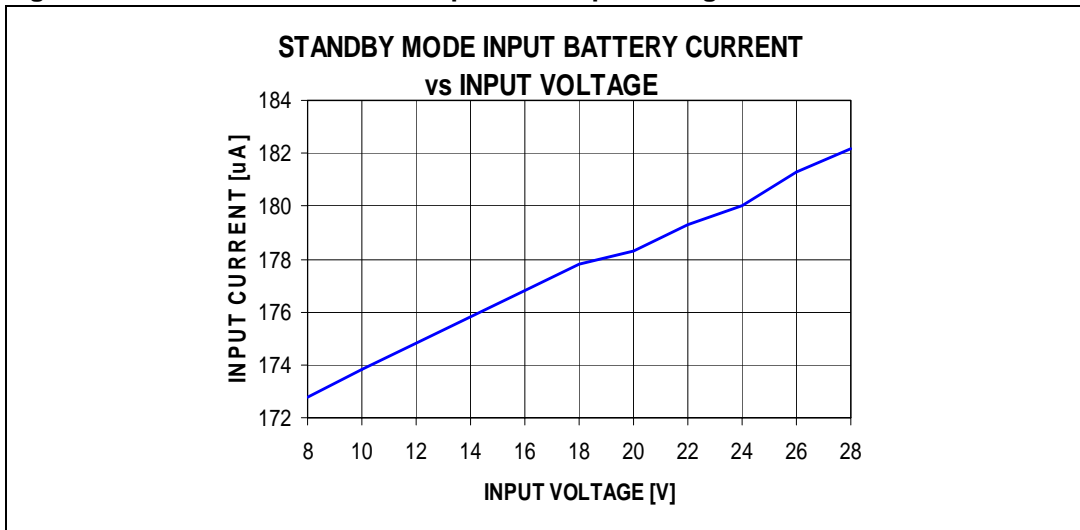

Figure 19. Device current consumption vs. input voltage



10.6 Switching frequency vs. load current

Figure 20 and Figure 21 show the switching frequency variation with the load current in PWM mode, skip mode and no-audible skip mode. 12 V is applied at the V_{IN+} and V_{IN-} test points.

Figure 20. OUT1 switching frequency vs. load current

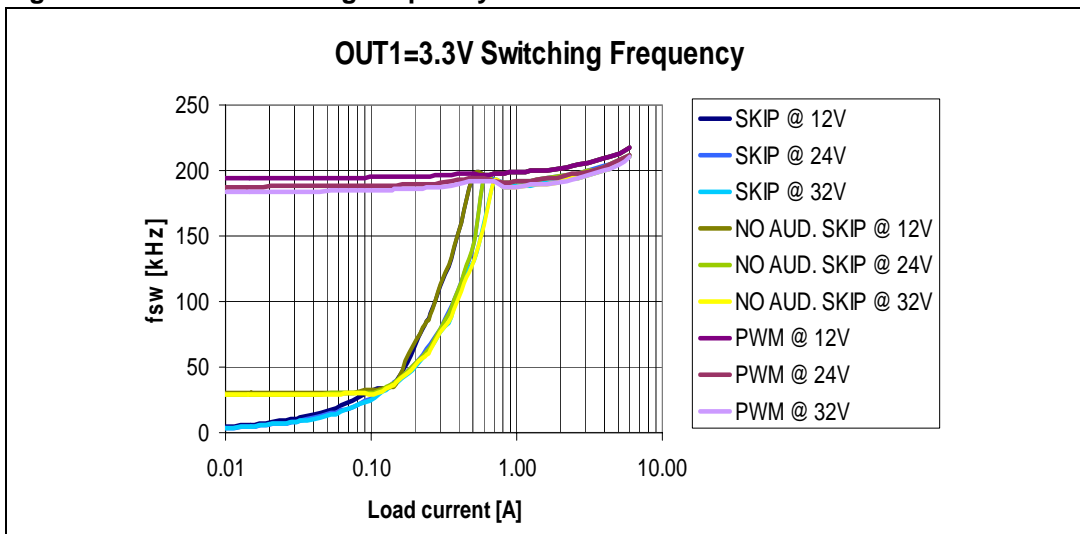
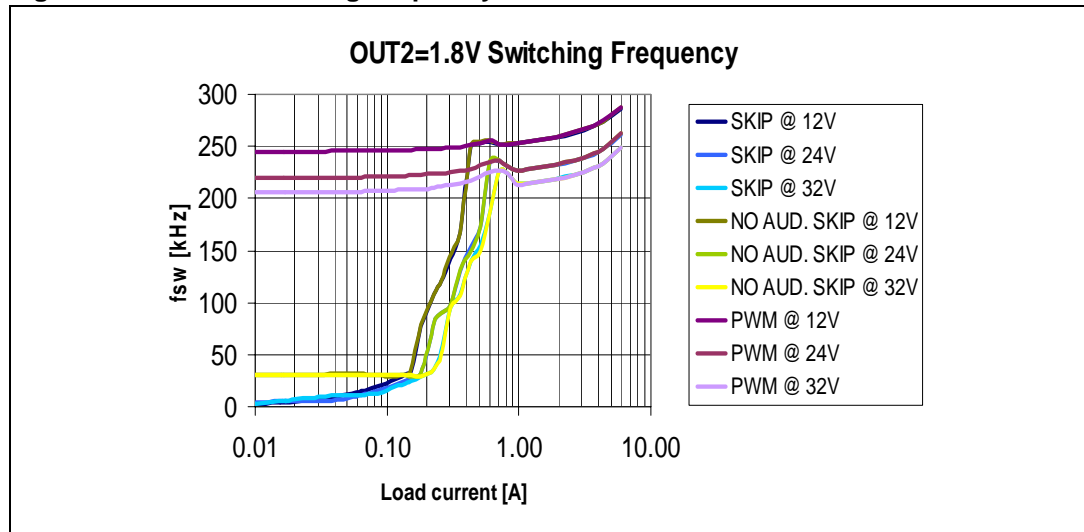

Figure 21. OUT2 switching frequency vs. load current



10.7 Linear regulator output voltages vs. output current

Figure 22 shows the load regulation for the internal linear regulator LDO5. Both switching sections are disabled and 12 V is applied at V_{IN+} and V_{IN-} test points.

Figure 22. LDO5 output vs. load current

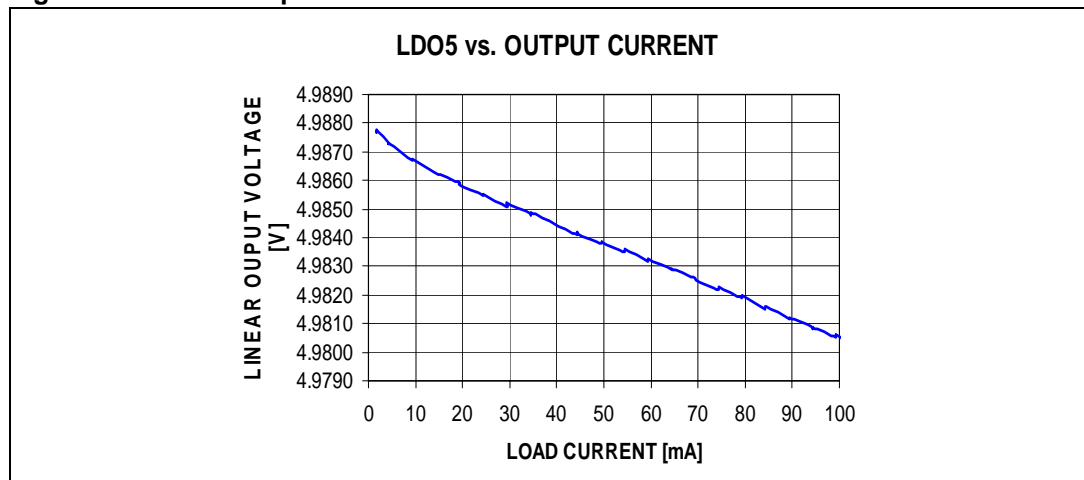

10.8 Load transient response

The following figures show the load transient response from 1 A to 4 A for both switching outputs. In each of these cases the PM6680A works in forced PWM mode (the SKIP pin is high).

Figure 23. OUT1 load transient response

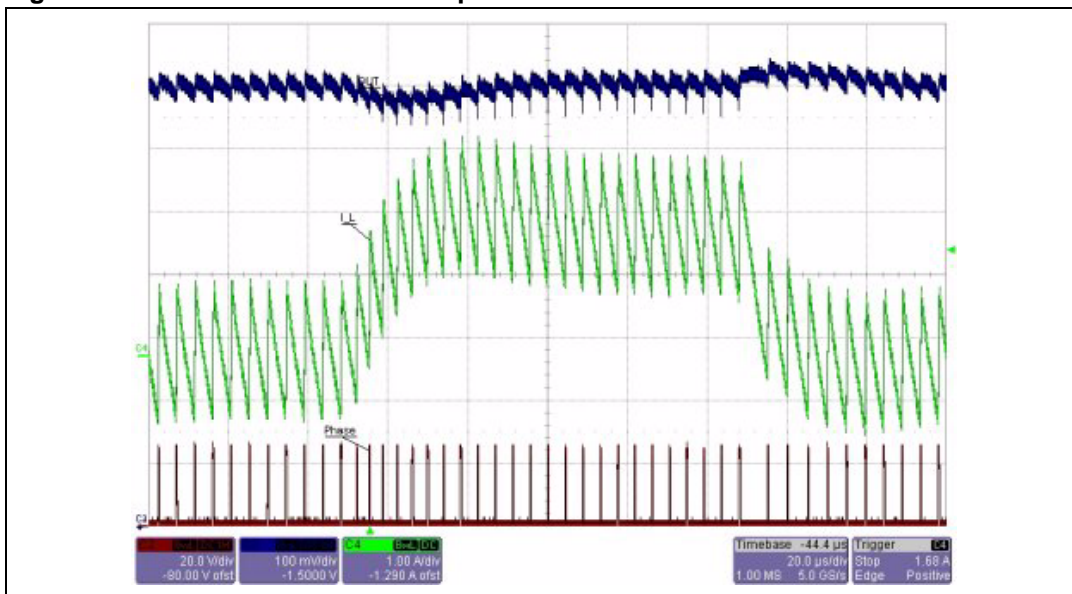
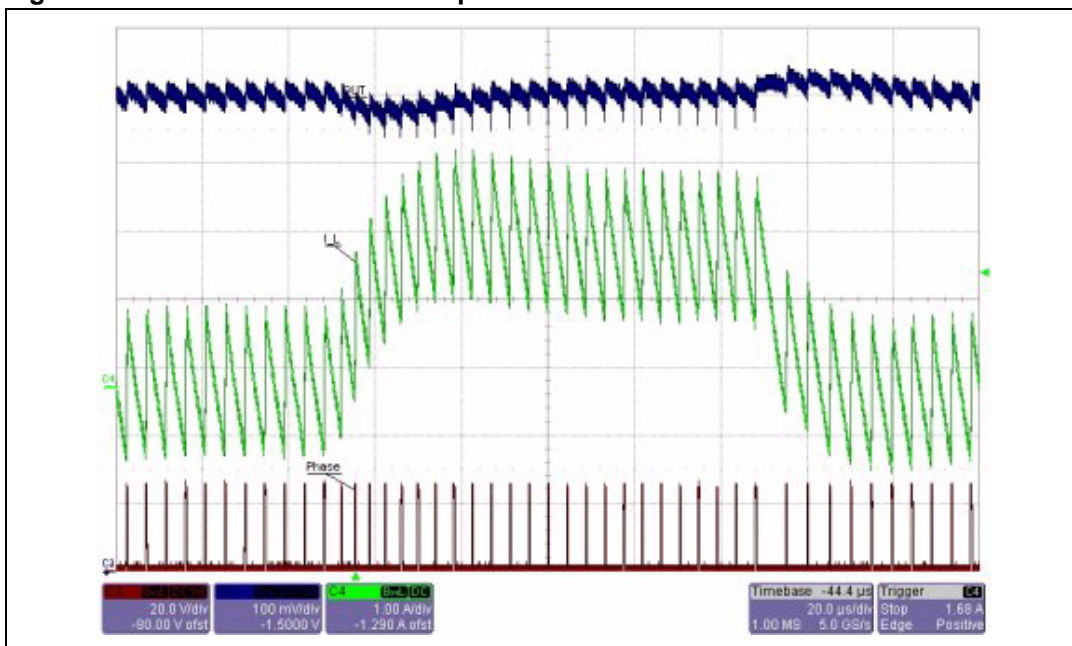

Figure 24. OUT2 load transient response



11 Representative waveforms

The following illustrations show the relevant waveforms of a switching section and are provided to underline the behavior of the device in pulse skip mode, no-audible skip mode and forced PWM mode working conditions.

Figure 25. SMPS pulse skip mode

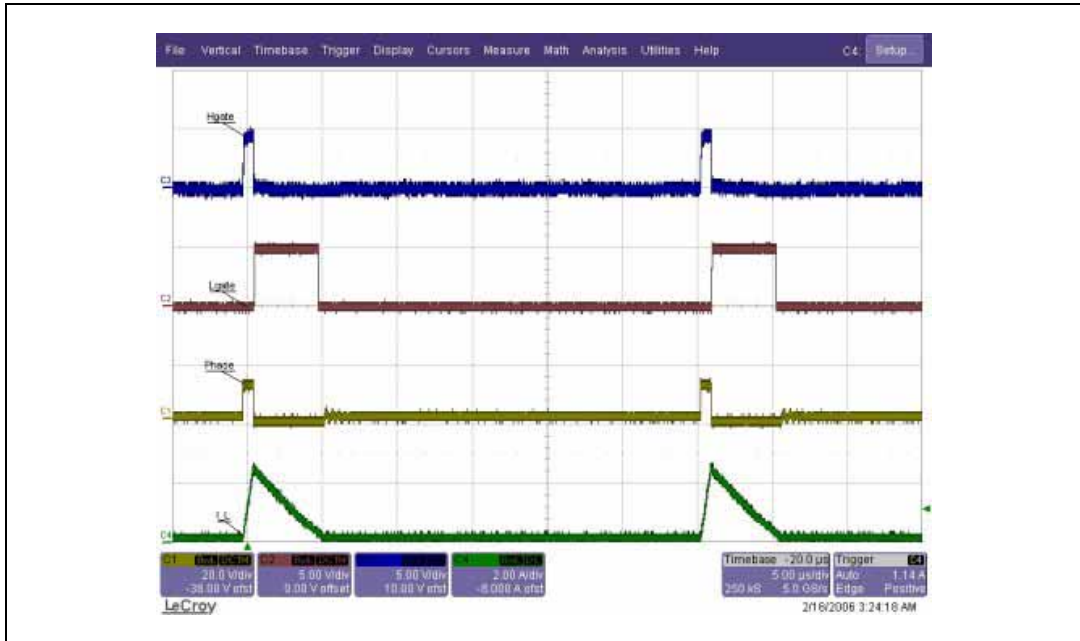

Figure 26. SMPS no-audible skip mode

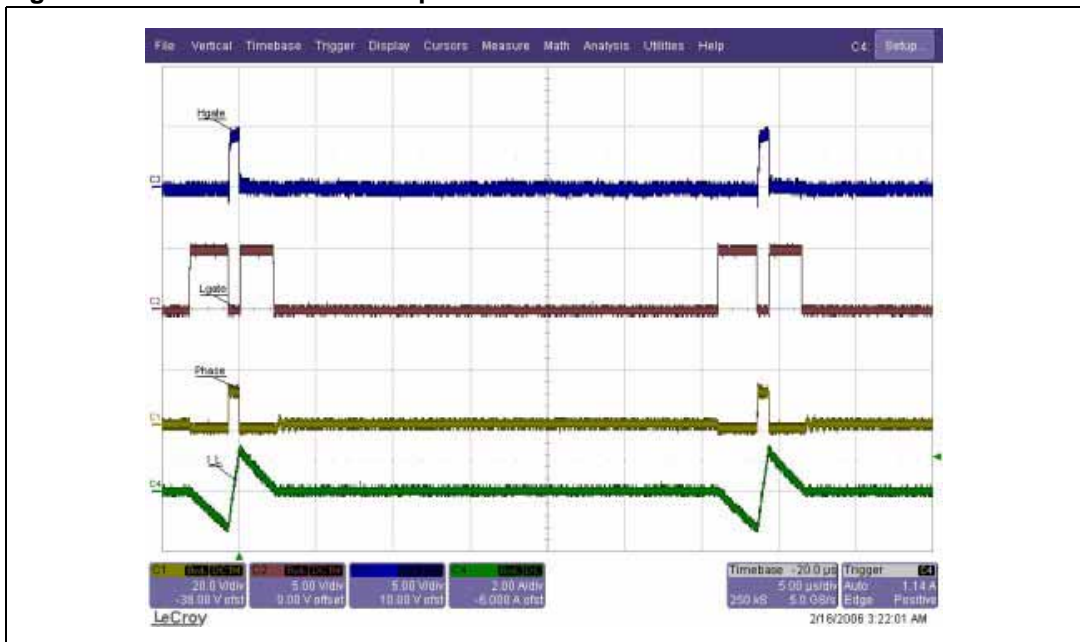
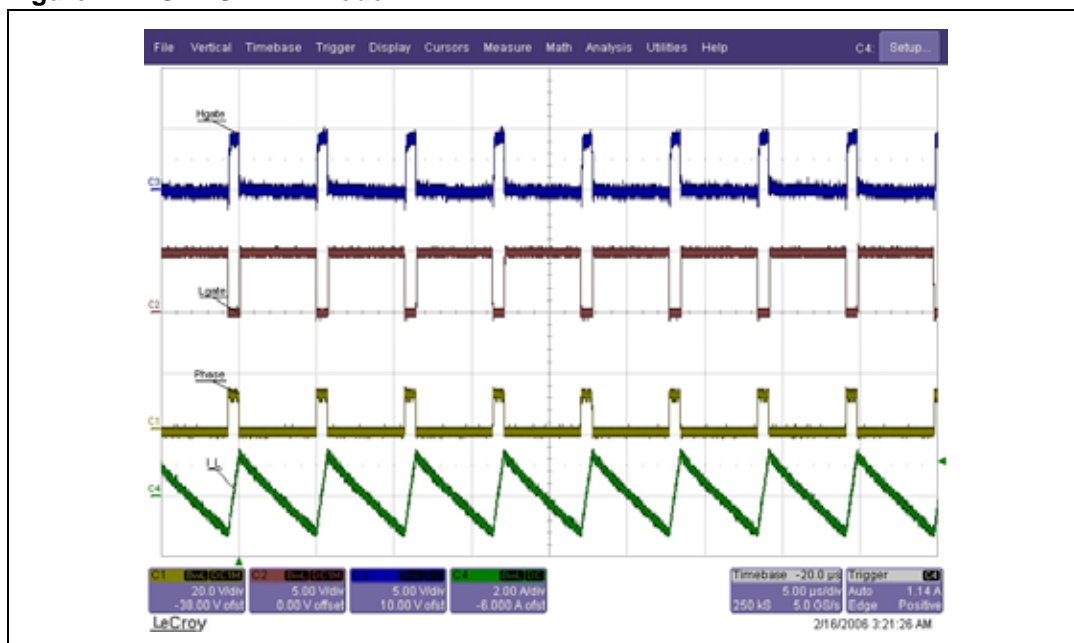

Figure 27. SMPS PWM mode



12 Revision history

Table 10. Document revision history

Date	Revision	Changes
9-Aug-2007	1	Initial release
07-Apr-2008	2	– Changed: Figure 1, 2, 3, 4, 6, 8, 9, 10 – Modified: Table 1 – Minor text changes

Please Read Carefully:

Information in this document is provided solely in connection with ST products. STMicroelectronics NV and its subsidiaries ("ST") reserve the right to make changes, corrections, modifications or improvements, to this document, and the products and services described herein at any time, without notice.

All ST products are sold pursuant to ST's terms and conditions of sale.

Purchasers are solely responsible for the choice, selection and use of the ST products and services described herein, and ST assumes no liability whatsoever relating to the choice, selection or use of the ST products and services described herein.

No license, express or implied, by estoppel or otherwise, to any intellectual property rights is granted under this document. If any part of this document refers to any third party products or services it shall not be deemed a license grant by ST for the use of such third party products or services, or any intellectual property contained therein or considered as a warranty covering the use in any manner whatsoever of such third party products or services or any intellectual property contained therein.

UNLESS OTHERWISE SET FORTH IN ST'S TERMS AND CONDITIONS OF SALE ST DISCLAIMS ANY EXPRESS OR IMPLIED WARRANTY WITH RESPECT TO THE USE AND/OR SALE OF ST PRODUCTS INCLUDING WITHOUT LIMITATION IMPLIED WARRANTIES OF MERCHANTABILITY, FITNESS FOR A PARTICULAR PURPOSE (AND THEIR EQUIVALENTS UNDER THE LAWS OF ANY JURISDICTION), OR INFRINGEMENT OF ANY PATENT, COPYRIGHT OR OTHER INTELLECTUAL PROPERTY RIGHT.

UNLESS EXPRESSLY APPROVED IN WRITING BY AN AUTHORIZED ST REPRESENTATIVE, ST PRODUCTS ARE NOT RECOMMENDED, AUTHORIZED OR WARRANTED FOR USE IN MILITARY, AIR CRAFT, SPACE, LIFE SAVING, OR LIFE SUSTAINING APPLICATIONS, NOR IN PRODUCTS OR SYSTEMS WHERE FAILURE OR MALFUNCTION MAY RESULT IN PERSONAL INJURY, DEATH, OR SEVERE PROPERTY OR ENVIRONMENTAL DAMAGE. ST PRODUCTS WHICH ARE NOT SPECIFIED AS "AUTOMOTIVE GRADE" MAY ONLY BE USED IN AUTOMOTIVE APPLICATIONS AT USER'S OWN RISK.

Resale of ST products with provisions different from the statements and/or technical features set forth in this document shall immediately void any warranty granted by ST for the ST product or service described herein and shall not create or extend in any manner whatsoever, any liability of ST.

ST and the ST logo are trademarks or registered trademarks of ST in various countries.

Information in this document supersedes and replaces all information previously supplied.

The ST logo is a registered trademark of STMicroelectronics. All other names are the property of their respective owners.

© 2008 STMicroelectronics - All rights reserved

STMicroelectronics group of companies

Australia - Belgium - Brazil - Canada - China - Czech Republic - Finland - France - Germany - Hong Kong - India - Israel - Italy - Japan - Malaysia - Malta - Morocco - Singapore - Spain - Sweden - Switzerland - United Kingdom - United States of America

www.st.com

