VVC Tuner



VVC Tuner

■ INTRODUCTION

VVC tuner is a significant component parts of TV. It receives and selects the RF signal on the air. A receiver translates the desired RF frequency to one intermediate frequency before demodulation. Modulation information is recovered from last IF(Intermediate Frequency) signal. Tuner is to be classified into NTSC and PAL type. Each type observes the FCC and CCIR Standards.

■ FEATURE & APPLICATION

● Feature

- Low Cost, Small Space
- High Immunity Design For EMC
- COMPACT Type (Pin Configuration , Dimension)
- Unify Power
- Tuner Supply Voltage 5V & 33V
- High Performance & Reliability
- All Channel Assignments are Available (NTSC , PAL)

● Application

- TV

VVC Tuner

■ STRUCTURE

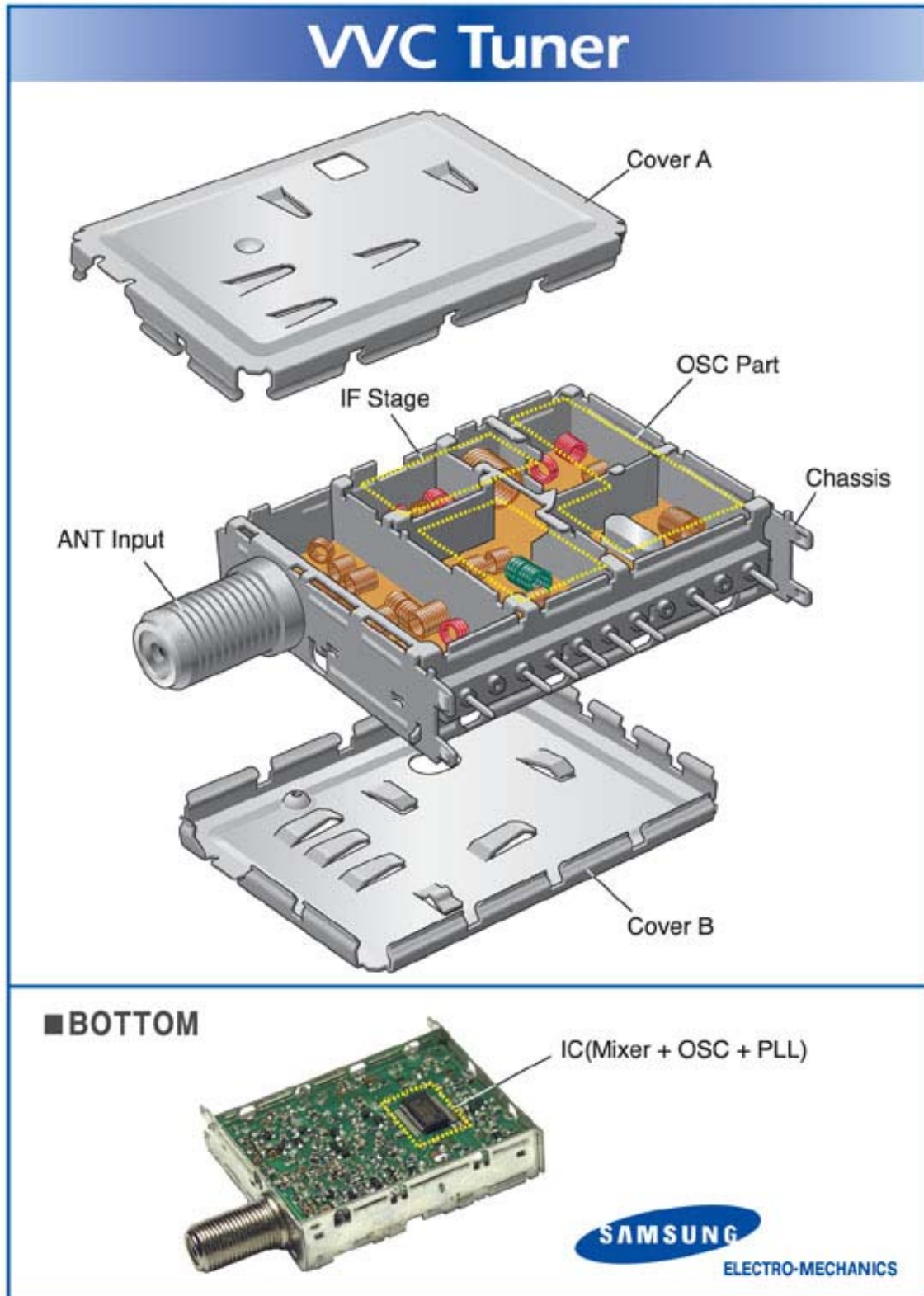

■ PART NUMBERING

TECC 0 9 4 9 P G 40 A(S)

① ②③④⑤ ⑥⑦⑧ ⑨

- ① ELECTRONIC TUNER
- ② Receiving System
- ③ Jack Type
- ④ AGC Supply Voltage
- ⑤ Receiving Channel Range
- ⑥ Tuning System
- ⑦ B+ Supply Voltage
- ⑧ Chassis Type
- ⑨ Revision Number (BUYER)

② RECEIVING SYSTEM

NO.	RECEIVING SYSTEM
1	NTSC
2	PAL B/G
3	JAPAN
4	AUSTRALIA
5	U.K.
6	S.A. OR OIRT
7	PAL D/K
8	ITALY
9	FRANCE
0	MULTI

③ JACK TYPE

NO.	TYPE
1	300Ω + 300Ω
2	300Ω ONE INPUT
3	300Ω + 75Ω (F CONNECTOR)
4	NOT AVAILABLE
5	300Ω + 75Ω (PHONE)
6	300Ω + 75Ω (DIN)
7	NOT AVAILABLE
8	75Ω ONE INPUT(PHONE)
9	75Ω ONE INPUT(DIN)
0	75Ω ONE INPUT(F CONNECTOR)

VVC Tuner

④ AGC SUPPLY VOLTAGE

NO.	VOLTAGE
0	1.7V
4	4.0V
6	6.5V
7	7.0V
8	8.0V(7.5V)

⑤ RECEIVING CHANNEL RANGE

NO.	NTSC CH.	PAL CH.
1	69	-
2	-	-
3	82	STANDARD
4	-	-
5	105	CABLE
6	110	-
7	-	-
8	-	-
9	139	FULL BAND
0	155,181	-

⑥ TUNING SYSTEM

ITEM	TUNING METHOD
V	VOLTAGE SYNTHESIZING
L	LOP
F	FREQUENCY SYNTHESIZING
P	PLL

⑦ B+ SUPPLY VOLTAGE

ITEM	B+	AFC
A	12	6.5
L	12	4.5
K	12	-
D	9	4.5
J	9	-
G	5	2.5

TECC 1070 PG 26 B

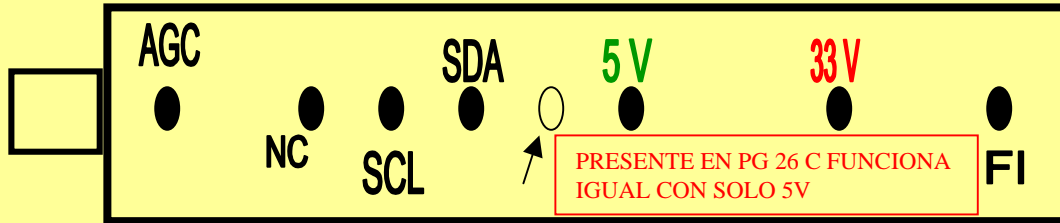

DT5 NF 20 D

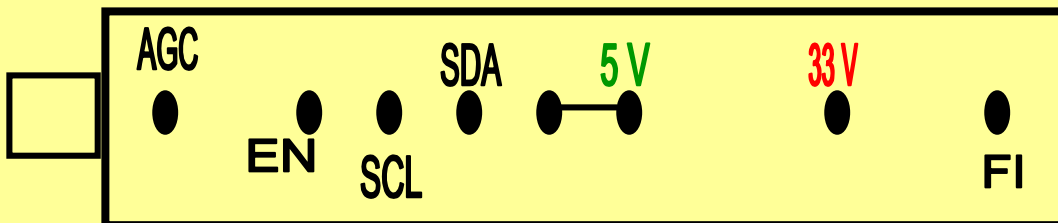

TECC 1970 PG 26 A (S)

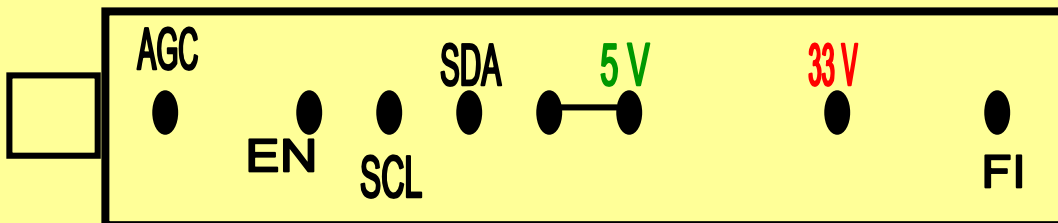

DT9 NF 10 D (NOBLEX 627)

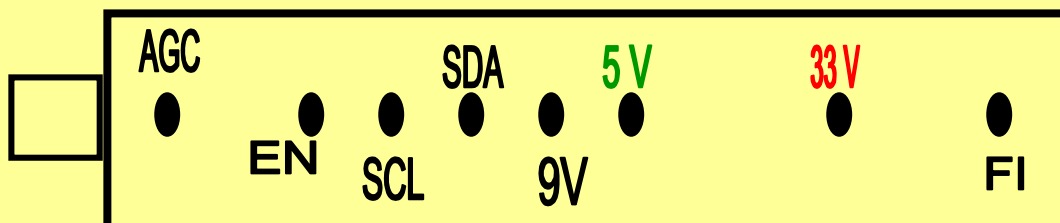



TUSH8 C 90 E

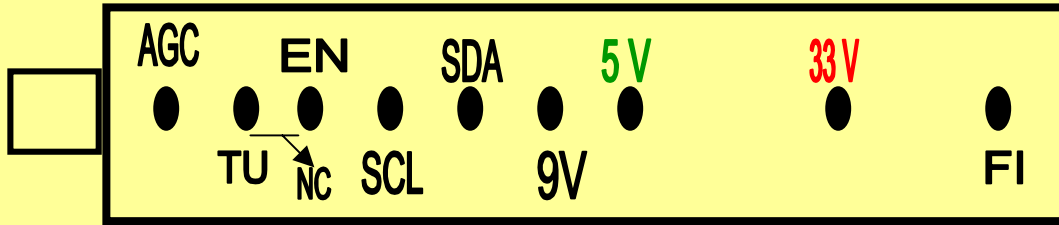

TAEC H 004 D

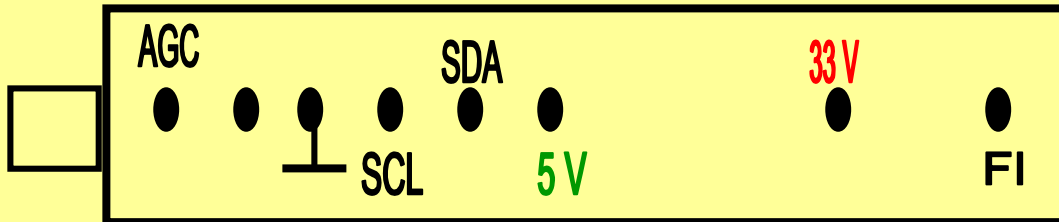

TECC 1980 PK 25 A

NOBLEX TC 615 Y SAMSUNG 5038/39

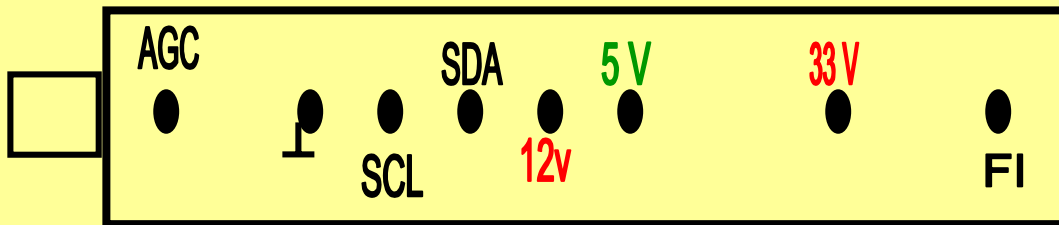

UV 936

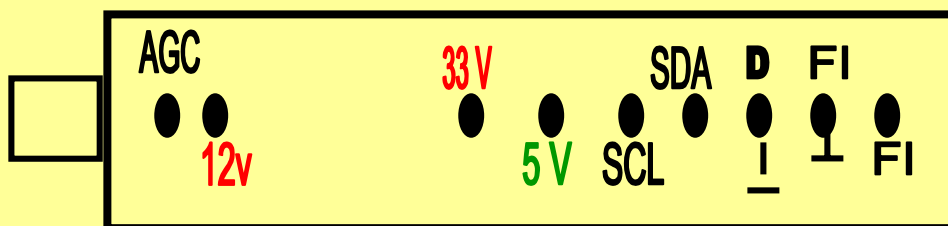

Sintonizador 1AV4F1BAM0211 SANYO (China) Chasis LA4-A el mismo diagrama es válido para F 1BAM0211 ó F 1BAM0231

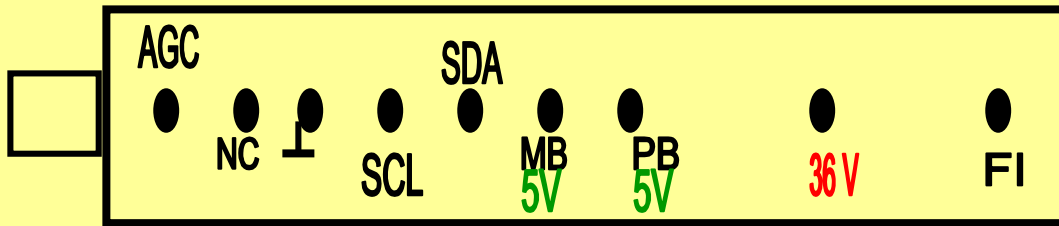

QAU0069-001
ENV56D44G3
JVC CT 2091

SE REEMPLAZA
POR EL TECC 1070 PG 26 B

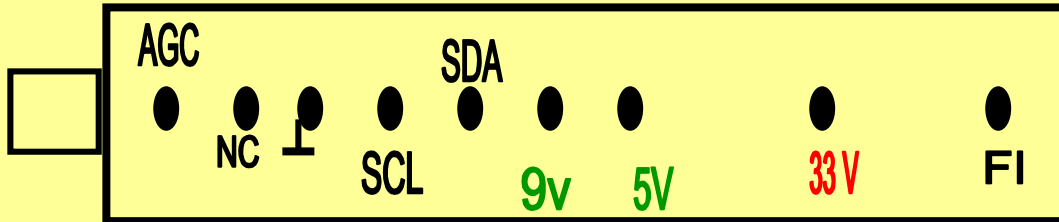

TELH9 250 B

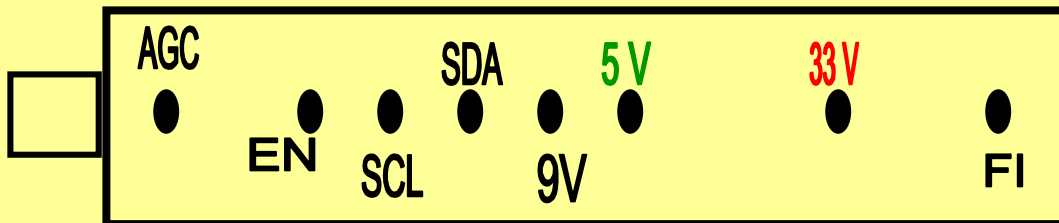



TUSH8 A 90 B

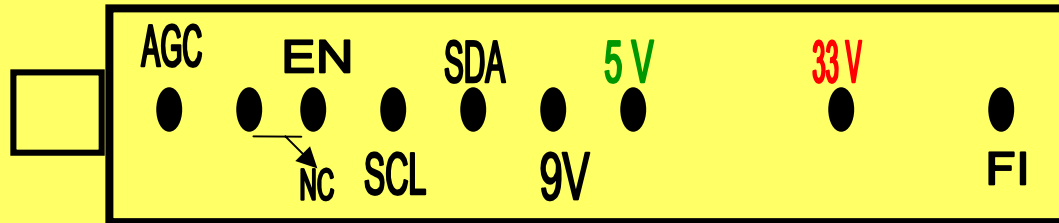



TDF 3M3

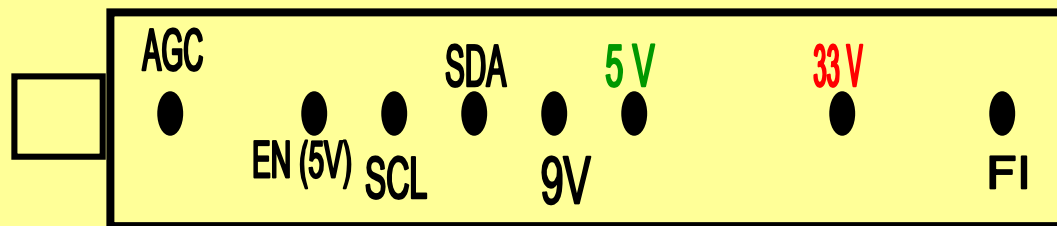

MITSUMI UVE50 AW 14 D (9723 F) (6 PINES)
 SAMSUNG TECC 1880 PA 08 A (V) (5 PINES)
 SAMSUNG TECC 1880 PA 09 C (5) (5 PINES)
 113-198 (6 PINES)
 TUGH8-A04 A (6 PINES)= AL F04A /SAMSUNG /SANYO/DEWO
 TUGH9-A07 A (6 PINES)
 GOLDSTAR 113-241 A (6 PINES)
 GOLDSTAR 113-241 C (6 PINES)

CHR 7A 703 B
 113-245 A= VCR HITACHI
 DTS NF 20 D= TV HITACHI
 ET 3D1 EW=TECC 1980 VA 15 A
 TAEC H 004 D = TV NOBLEX VARIOS
 TAEC H 010 F = TV DAEWOO
 TECC 1070 PG 26 B = TV SAMSUNG
 TECC 1070 PG 26 C = SAMSUNG
 TELH9 250 B = TECC 1880 PK 25 A TAEC H 004D = DT5 NF 20 D
 TUGH9-A04 M = TECC 1880 PA 21

LOS DE 6 PINES VAN POR LOS DE 5 PINES

SINTO VCR SANYO 1AV4F1FAM0050/VA065AA (VHR 351 Z)
VVR SONY SLV L 44 AR
SINTO SANYO 115-V 0125A SE REEMPLAZA POR EL ANTERIOR Y POR EL TMVH 1-106B
SIRVE PARA REEMPLAZAR SINTOS EN TVS GOLDSTAR / LG / SERIE DORADA
CORTANDOLE LAS 5 PATITAS DEL MODULADOR DE RF Y EL CONECTOR DE SALIDA DE RF

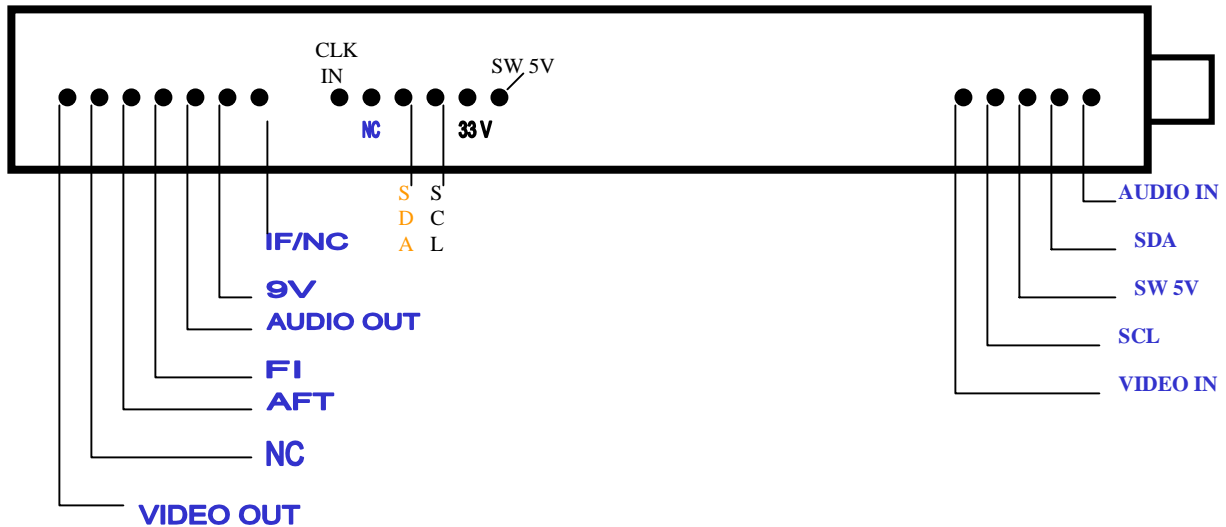

EQUIVALENCIA DE SINTONIZADORES

MITSUMI UVE50 AW 14 D (9723 F) (6 PINES)
SAMSUNG TECC 1880 PA 08 A (V) (5 PINES)
SAMSUNG TECC 1880 PA 09 C (5) (5 PINES)
113-198 (6 PINES)
TUGH8-A04A (6 PINES)= AL F04A
TUGH9-A07A (6 PINES)
GOLDSTAR 113-241 A (6 PINES)
GOLDSTAR 113-241 C (6 PINES)
CHR 7A 703 B

LOS DE 6 PINES VAN POR LOS DE 5 PINES

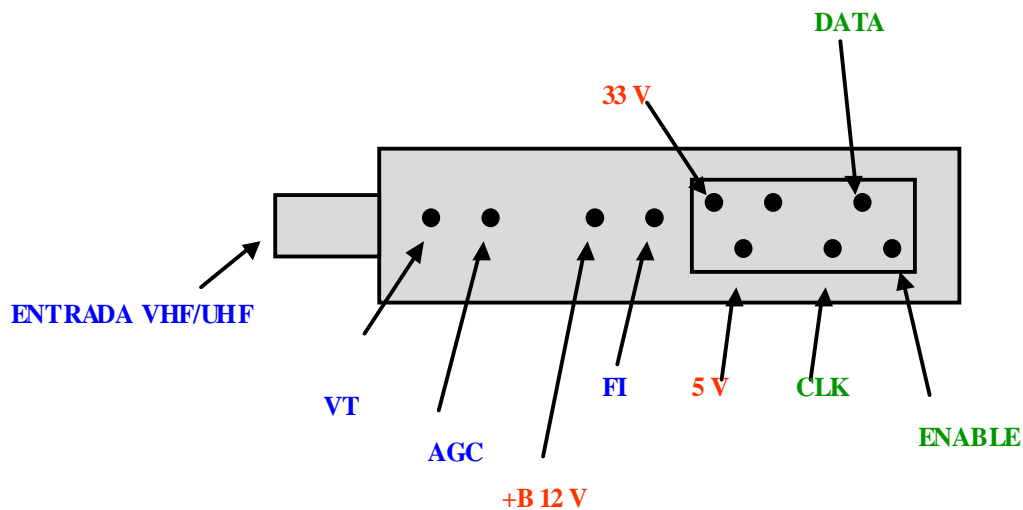

PROBADOS EN UN PHILCO 21 F 29 RC.
NO SIGNIFICA QUE FUNCIONEN TODOS EN OTROS CHASIS

IMPORTANTE!!

SE PUEDEN REEMPLAZAR SINTOS LARGOS POR SINTOS CORTOS
RESPECTANDO LOS PINES SEGÚN ESQUEMAS

CONEXIONES SINTOS

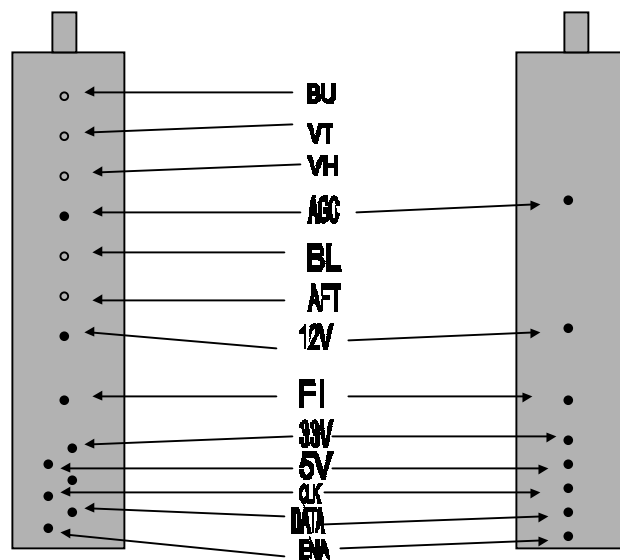

2003 NEW

ALPS

Compact Analog Broadcasting Tuner

TEQ Series

A small 22 ml mounted body, approximately half the size of the industry standard.

■ Features

- A smaller body (22ml), approximately 50% of the size of our existing model (TED series); this has been achieved by high-density mounting technology and our proprietary U/V OSC/MIX combination full custom IC.
- High-quality, stable reception from the improved noise figure and power gain.
- With the exception of aerial height, the mounted shape is the standard industry size.
- Station selection is by PLL only with the I²C bus as standard.
- Three types of input connector are provided : Phono, IEC and F.

■ Applications

- TV, LCD TV, DVD recorder, plasma TV, projection TV, etc.



■ Typical Specifications

Items		Specifications		
		U.S.A. model	EU model	Japan model
Receiving channel		VHF Low : ch2~B High : chC~W+11 UHF : chW+12~69	VHF Low : chE2~S6 High : chS7~S36 UHF : S37~69	VHF Low : ch1~C22 High : ch4~C52 UHF : chC53~62
Intermediate frequency		VIF : 45.75MHz SIF : 41.25MHz	VIF : 38.9MHz SIF : 33.4MHz	VIF : 58.75MHz SIF : 54.25MHz
Input impedance	ANT IN	75 Ω (Unbalanced)		
Output impedance	IF-OUT	75 Ω (Unbalanced)		

2003 NEW

ALPS

Compact Analog Broadcasting Tuner Unit with Built-in IF & Sound Multiplexed Demodulator

TMQ Series

With built-in IF and a multiplexed sound circuit, this model is consistent with the industry standard size of 30ml.

■ Features

- A smaller body (30ml), approximately 60% of the size of our existing model (TED series); this has been achieved by high-density mounting technology and our proprietary U/V OSC/MIX combination full custom IC.
- High-quality, stable reception from the improved noise figure and power gain.
- Suitable to Japanese and U.S.A. sound multiplexed systems.
- ANT splitter is internally installable: optional.

■ Applications

- TV, LCD TV, DVD recorder, plasma TV, projection TV, etc.

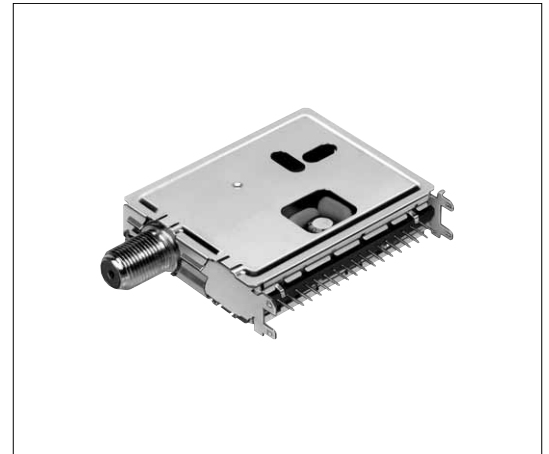

■ Typical Specifications

Items		Specifications		
		U.S.A. model	EU model	Japan model
Receiving channel		VHF Low ch2~B High chC~W+11 UHF chW+12~69	VHF Low chE2~S6 High chS7~S36 UHF S37~69	VHF Low ch1~C22 High ch4~C52 UHF chC53~62
Intermediate frequency		VIF 45.75MHz SIF 41.25MHz	VIF 38.9MHz SIF 33.4MHz	VIF 58.75MHz SIF 54.25MHz
Input impedance	ANT IN	75 Ω (Unbalanced)		
Output impedance	IF-OUT	75 Ω (Unbalanced)		
	Video out	1Vp-p / 1kΩ term		
	Audio out	-15dBs / 100kΩ term		

CATV Up/Down Converter CATV 15 Series

OUTLINE

CATV15 CONVERTER is use max. 83ch CATV Cable SETTOP system.

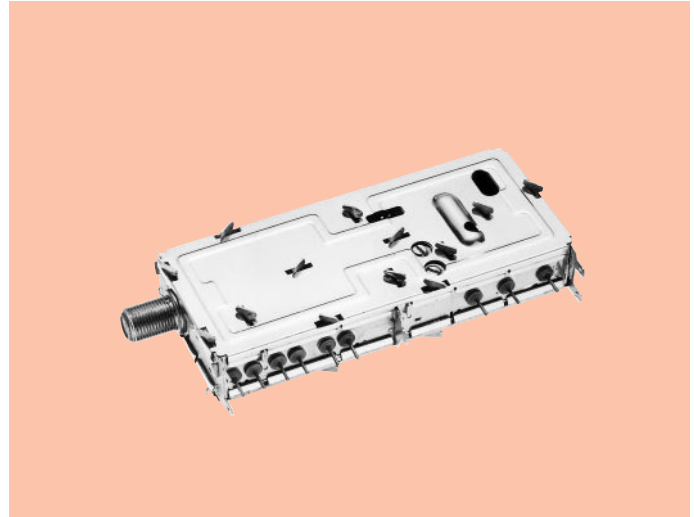

FEATURES

1. Input frequency is 50 to 550MHz.
2. Use chip component Small and lightweight.
3. 1st IF (612MHz) use HERICAL filter and dielectric filter. High quality.
4. Included prescaler IC.

SPECIFICATIONS

Item	CATV15-A56F	CATV15-E56F
Input Frequency Range	52~552MHz	45~552MHz
Output Channel	US BASE BAND	European BASE BAND
Input Impedance	75Ω	75Ω
Output Impedance	75Ω	75Ω
Input Return Loss	7dB min.	7dB min.
Output Return Loss	12dB min.	12dB min.
Input Signal Level	-5~+15dBmV	-5~+15dBmV
Power Gain	20~30dB	20~30dB
Noise Figure	10dB max.	10dB max.
Supply Voltage	12V : 200mA max. 5V : 30mA max.	12V : 200mA max. 5V : 30mA max.
Prescaler Output Level	0.5Vp-p min.	0.5Vp-p min.
Gain Reduction	20dB min.	20dB min.

Digital CATV Up/Down Converter CATV 19 Series

OUTLINE

The cable television 19 series is a small up-down converter for set-top boxes with digital television broadcasts.

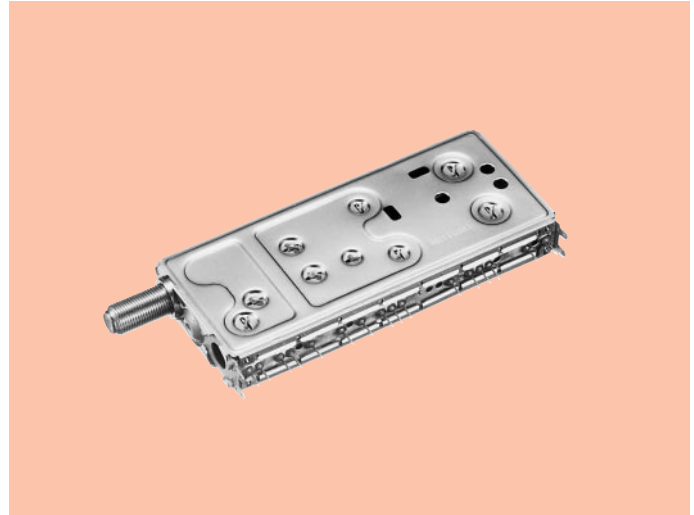

FEATURE

1. The built-in PLL circuit is superior for phase noise.
2. Capable for use with interactive telecommunications with PSK/FSK terminals.
3. Receives signals from a wide input frequency (50~860MHz).
4. Small and thin for mounting on PC boards.
5. Superior flatness characteristics within the band range.

SPECIFICATIONS

Item	CATV19-A07D
Input Frequency Range	52~860MHz
Output Channel	US BASE BAND
Input Impedance	75Ω
Output Impedance	75Ω
Input Return Loss	10dB typ.
Output Return Loss	16dB typ.
Input Signal Level	-10~+15dBmV
Power Gain	30dB typ.
Noise Figure	8dB typ.
Supply Voltage	9V : 260mA typ. 29V : 4mA typ.
Phase Noise	-88dBc/Hz typ. (10kHz, During OFF SET)
Gain Reduction	20dB min.

RF Discrete solution for TV tuner

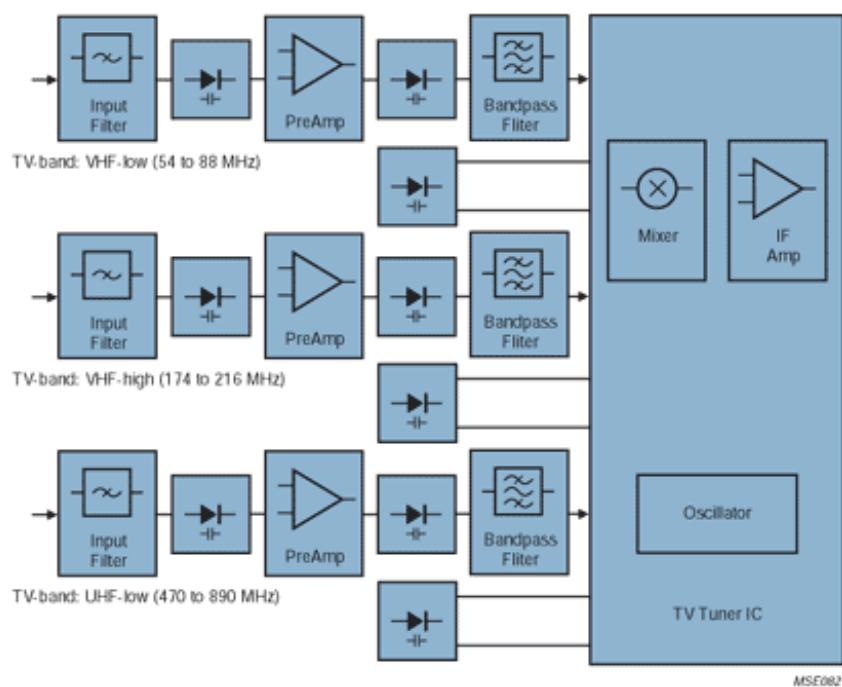

Tuner Unit Built-in Demodulator for Digital Terrestrial Broadcasting

TDH Series

A unified configuration model common to BS and CATV in a 30%-smaller size (compared to our similar products).

■ Features

- A variety of models with identical external dimensions and demodulation systems compatible with broadcasting systems in Japan, the U.S. and Europe is available. Models for North American terrestrial broadcasting have a built-in demodulating function for analog broadcasting on NTSC as option.
- Newly developed Custom IC Mixer/OSC/PLL on one chip and our high-density mounting technology have achieved a compact size.
- The TDH series allows for TS output for set manufactures.
TS : Transport Stream

■ Applications

- Digital broadcasting receivers such as digital TV, set-top boxes, VCRs, and PCs.



■ Typical Specifications

Items	Specifications		
	For USA (8VSB)	For Europe (OFDM)	For Japan (OFDM)
From of ANT input	1-Input 1-input,1-output		
Type of control	I ² C bus control		
Receiving frequency	Full band	UHF / VHF and UHF	
Receivable mode	8-VSB,QAM, NTSC	OFDM 2K and 8K	OFDM 8K

Compact (25cc) Tuners for TV, VCR UVE25-JW60D, JW61D, JW57D

TV/VCR Tuners, RF Modulators

FEATURES

1. A small shape of world wide standard type.
2. With PLL IC (I²C bus).
3. Power source voltage +B=5V.
4. IF output corresponds to an unbalanced output.
5. Used one IC (MUX+OSC+PLL).

JW60D(Standing Type)

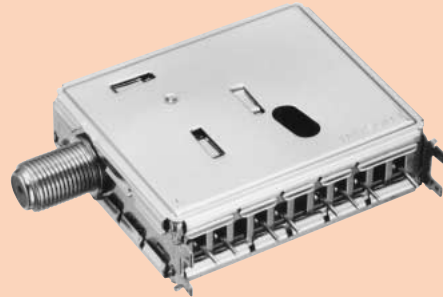

JW61D(Standing type with splitter)



JW57D(Horizontal type)

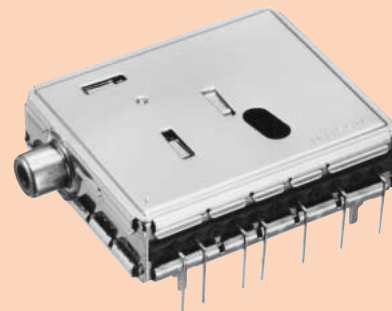

SPECIFICATIONS

Item	Specifications	Unit
	UVE25-JW60D	
Input Frequency Range	91.25~765.25	MHz
Output Frequency	58.75	MHz
Input Impedance	75	Ω
Supply Voltage	5	V
V.S.W.R.	VHF : 7, UHF : 7 max.	—
Noise Figure	VHF : 10 max., UHF : 10 max.	dB
Power Gain	VHF : 32 min., UHF : 32 min.	dB
Cross Modulation	VHF : 65, UHF : 65 min.	dB
Tuning Curve	VHF : 2.5~23.5, UHF : 1~24	V
Image Rejection	VHF : 50, UHF : 45 min.	dB
Gain Reduction	VHF : 36, UHF : 36 min.	dB
+B Drift	VHF : ±70, UHF : ±70 max.	kHz

*Note Specifications subject to change without notice.

Tuners, IF Unit for TV, VCR TPS39-J02

FEATURES

1. The combination of world wide standard tuner + IF circuit makes for excellent versatility.
2. PLL detector used in IF section.
3. I²C bus PLL system used for tuner.

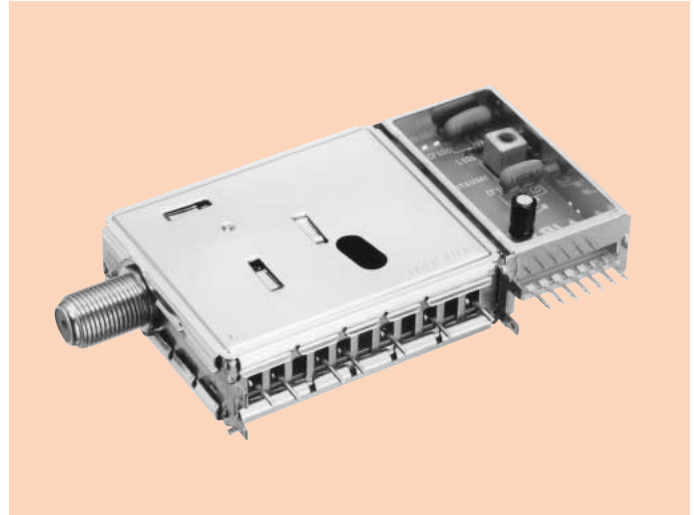

MODEL NAME CODE

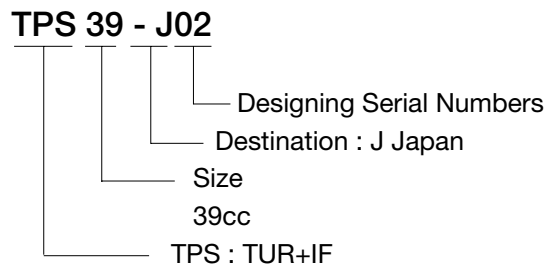

BLOCK DIAGRAM

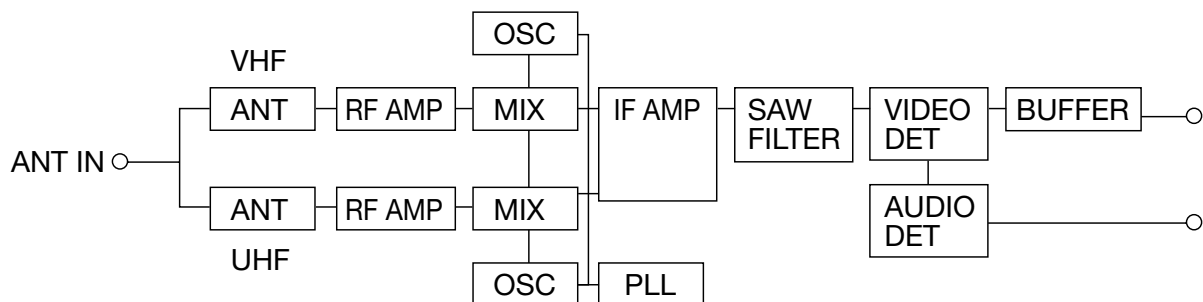

SPECIFICATIONS

Item	Specifications	Unit
Image Rejection	VHF : 75typ., UHF : 70typ.	dB
IF Rejection	VHF : 100typ., UHF : 100typ.	dB
Video Output Level	1.0typ.	Vp-p
Audio Output Level	-10	dBV
Video S/N Ratio	48typ.	dB
Audio S/N Ratio	50typ.	dB
Supply Voltage	5, 32	V

*Note Specifications subject to change without notice.

Compact (25cc) Tuners for TV, VCR UVE25-EW65D, UE25-B59D

TV/VCR Tuners, RF Modulators

FEATURES

1. A small shape of world wide standard type.
2. With PLL IC (I²C bus).
3. Power source voltage +B=5V.
4. IF output corresponds to an unbalanced output.
5. Used one IC (MUX+OSC+PLL).

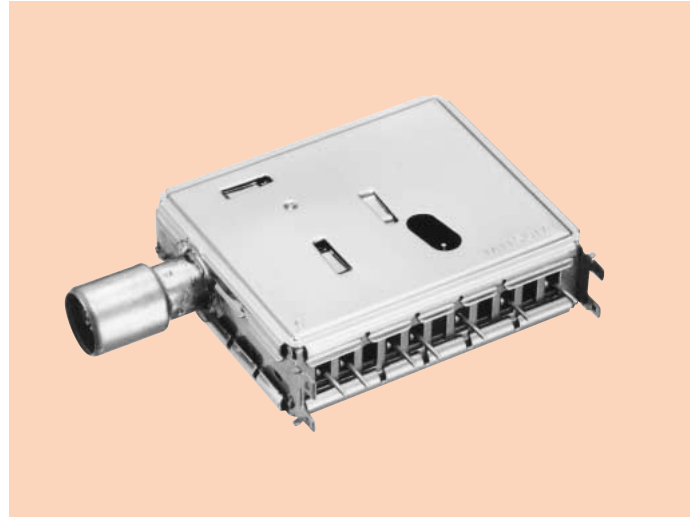

MODEL NAME CODE

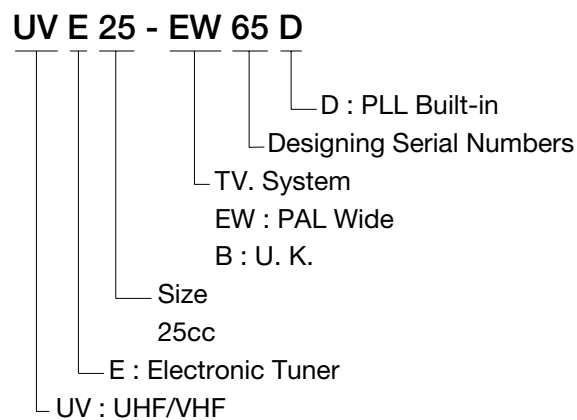

BLOCK DIAGRAM

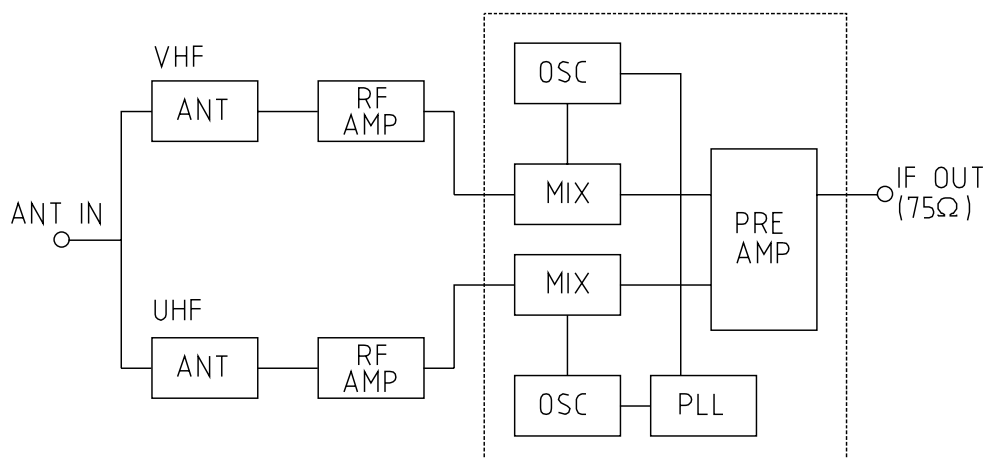

Compact (25cc) Tuners for TV, VCR UVE25-AW66D

FEATURES

1. A small shape of world wide standard type.
2. With PLL IC (I²C bus).
3. Power source voltage +B=5V.
4. IF output corresponds to an unbalanced output.
5. Used one IC (MIX+OSC+PLL).



MODEL NAME CODE

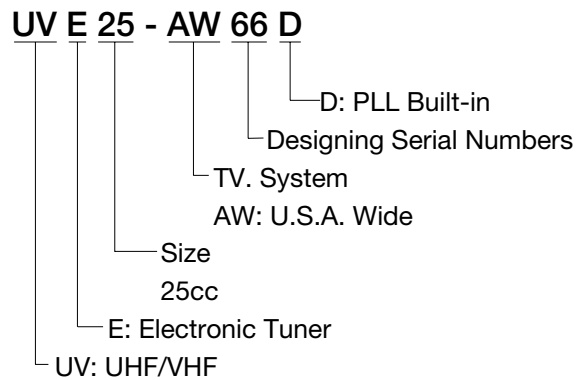

BLOCK DIAGRAM

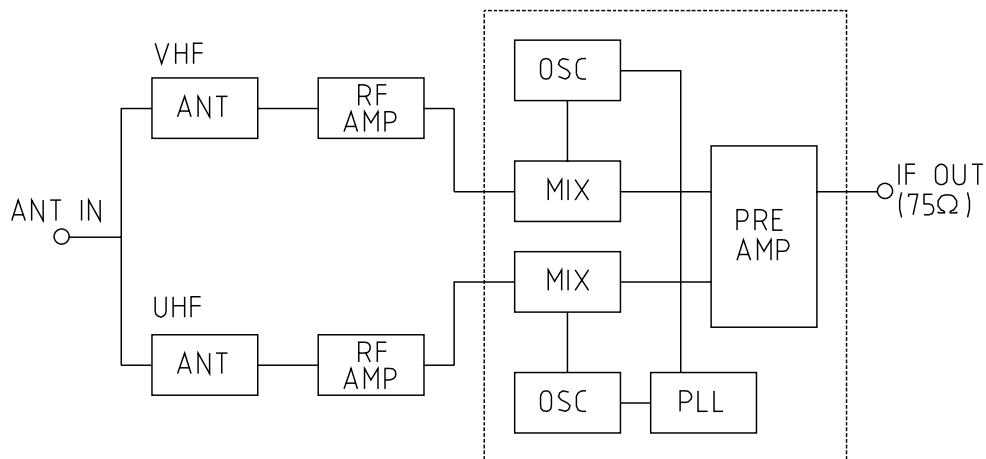

PRODUCT • Category

- [Resistors](#)
- [Capacitors](#)
- [Filters](#)
- [Oscillators](#)
- [Printed Circuit Boards](#)
- [Power Supplies](#)
- [Sensors](#)
- [Inductors](#)
- [DY](#)
- [FBT](#)
- [Diodes](#)
- [Speakers](#)
- [Motors](#)
- [Heads](#)
- [Drums](#)
- [Tuners](#)
- " TV tuners**
- [" PC TV Tuners](#)
- [" TM block Tuners](#)
- [" Cable Tuners](#)
- [" Satellite Tuners](#)
- [" Digital Terrestrials](#)
- [Keyboards](#)
- [Mouse](#)
- [RF Parts](#)
- [RF Parts](#)
- [Optical Components](#)
- [Decks](#)
- [Mini Printers](#)
- [Unit Parts](#)

TV Tuners

[NTSC PG30 Series](#) | [NTSC PG32 Series](#) | [PAL PG35 Series](#) | [PAL PL35 Series](#) | [PAL VG33 Series](#)

Analog TV - NTSC PG30 Series -

[top](#) | [next](#)

PICTURES



FEATURES

- PLL Circuit is built-in.(I2C or 3-WIRE)
- WORLD STANDARD PIN CONFIGURATION
- All channel assignments are available.(U.S.A and Japan)
- BP voltage is available for 5V.
- Adoption of the MIXER + OSC IC + PLL ONE CHIP IC against the interference characteristics

APPLICATIONS

- TV, VCR

PRODUCTS LINE-UP

Type	Model	Description					Fig
		B+	BP	Channel	PLL	Jack	
NTSC	TECC1070PG30A(S)	9V	5V	USA 181 CH	I ² C	F-CON	1

SUPPLY VOTAGE

	UHF	VHF High	VHF Low
BU	5V	OPEN	OPEN
VT	0.5V ~ 33V		
BH	OPEN	5V	OPEN
AGC	7.0V ~ 0V		
BL	OPEN	OPEN	5V
B+	9V		

BAND DATA

	UHF	VHF High	VHF Low
BS1	0	0	1
BS2	0	1	0
BS3	0	0	0
BS4	1	0	0

Analog TV - NTSC PG32 Series -

[top](#) | [next](#)

Sintonizador TUSH8-C90E, funcionó correctamente el TUSH8-C90F

Un párrafo aparte es lo comentado por Julián sobre estos sintonizadores, a saber: Todos los chasis DAE-YOUNG en general, llevan distintas versiones de sintonizadores, hay tres y las diferencias son las siguientes: los más antiguos se alimentan con 5 y 12v. En cambio otros lo hacen con 5 y 9v, pero la versión más moderna requieren 5 y 5v. En una palabra estos últimos cambiando la alimentación de +12v ó +9v según era el caso por los 5v necesarios reemplazan a todos los otros, fue confirmado por Julian. Si no entran todos los canales de cable ó aparecen solo algunos se debe a la tensión incorrecta en cuestión.

Lo recomendable cuando no se conoce la tensión correcta de alimentación del sintonizador es comenzar por aplicarle 5 y 5v, si la cosa no funciona recién probar con 5 y 9v, si aun persisten los problemas llegar a 5 y 12v. En un caso con 5 y 5v no tomaba ningún canal de cable, pero a aplicarle 5 y 9v todo se normalizo.

Esta información la recibió en Philco.

PICTURES



FEATURES

- PLL Circuit is built-in.(I2C or 3-WIRE)
- WORLD STANDARD PIN CONFIGURATION
- All channel assignments are available.(U.S.A and Japan)
- BP voltage is available for 5V.
- Adoption of the MIXER + OSC IC + PLL ONE CHIP IC against the interference characteristics

APPLICATIONS

- TV, VCR

PRODUCTS LINE-UP

Type	Model	Description					Fig
		B+	BP	Channel	PLL	Jack	
NTSC	TECC1040PG32A		5V	USA 181 CH	I ² C	F-CON	1
	TECC1840PG32A		5V	USA 181 CH	I ² C	RCA	2
	TECC3045PG32A		5V	JAPAN	I ² C	F-CON	1
	TECC3845PG32A		5V	JAPAN	I ² C	RCA	2
	TECC3045SG32A		5V	JAPAN	I ² C	Splitter	3

SUPPLY VOTAGE

	UHF	VHF High	VHF Low
BU	5V	OPEN	OPEN
VT	0.5V ~ 33V		
BH	OPEN	5V	OPEN
AGC	4.0V ~ 0V		
BL	OPEN	OPEN	5V

BAND DATA

	UHF	VHF High	VHF Low
BS1	0	0	1
BS2	0	1	0
BS3	0	0	0
BS4	1	0	0
I2C, 3Wire Available			

Analog TV - PAL PG35 Series -

[top](#) | [next](#)

PICTURES



FEATURES

- PLL Circuit is built-in.(I2C)
- WORLD STANDARD PIN CONFIGURATION
- All channel assignments are available.(Europe and China)
- BP voltage is available for 5V.
- Adoption of the MIXER + OSC IC + PLL ONE CHIP IC against the interference characteristics

APPLICATIONS

- TV, VCR

PRODUCTS LINE-UP

Type	Model	Description					Fig
		B+	BP	Channel	PLL	Jack	
PAL	TECC2949PG35A	5V	1IF	45~870 MHz	I ² C	Din	1
	TECC2949PG35B	5V	1IF	45~870 MHz	I ² C	Din	

SUPPLY VOTAGE

	UHF	VHF High	VHF Low
BU	5V	OPEN	OPEN
BT	0.5V ~ 33V		
BH	OPEN	5V	OPEN
AGC	4.0V ~ 0V		
BL	OPEN	OPEN	5V
BP	5V		

BAND DATA

	UHF	VHF High	VHF Low
BS1	0	0	1
BS2	0	1	0
BS3	0	0	0
BS4	1	0	0
I2C Available			

Analog TV - PAL PL35 Series -

[top](#) | [next](#)

PICTURES



FEATURES

- PLL Circuit is built-in.(I2C)
- WORLD STANDARD PIN CONFIGURATION
- All channel assignments are available.(Europe and China)
- BP voltage is available for 5V.
- Adoption of the MIXER + OSC IC + PLL ONE CHIP IC against the interference characteristics
- Tuner+LNA(Low Noise Amplifier)

APPLICATIONS

- TV, VCR

PRODUCTS LINE-UP

Type	Model	Description					Fig
		B+	BP	Channel	PLL	Jack	
PAL	TECC2949PL35A	5V	1IF	45~870 MHz	I ² C	Din	1
	TECC2949PL35B	5V	2IF	45~870 MHz	I ² C	Din	

SUPPLY VOTAGE

BAND DATA

	UHF	VHF High	VHF Low
BU	5V	OPEN	OPEN
BT	0.5V ~ 33V		
BH	OPEN	5V	OPEN
AGC	4.0V ~ 0V		
BL	OPEN	OPEN	5V
BP	5V		

	UHF	VHF High	VHF Low
BS1	0	0	1
BS2	0	1	0
BS3	0	0	0
BS4	1	0	0
I2C Available			

Analog TV - PAL VG33 Series -

[top](#) | [next](#)

PICTURES



FEATURES

- WORLD STANDARD PIN CONFIGURATION
- All channel assignments are available.(Europe and China)
- B+ voltage is available for 5V.
- Adoption of the MIXER + OSC IC ONE CHIP IC against the interference characteristics.

APPLICATIONS

- TV, VCR

PRODUCTS LINE-UP

Type	Model	Description					Fig
		B+	BP	Channel	PLL	Jack	
PAL	TECC2949VG33A	5V	1IF	45~870 MHz		Din	1
	TECC2949VG33B	5V	2IF	45~870 MHz		Din	

SUPPLY VOTAGE

	UHF	VHF High	VHF Low
BU	5V	OPEN	OPEN
BT	0.5V ~ 33V		
BH	OPEN	5V	OPEN
AGC	4.0V ~ 0V		
BL	OPEN	OPEN	5V
BP	5V		

BAND DATA

	UHF	VHF High	VHF Low
BS1	0	0	1
BS2	0	1	0
BS3	0	0	0
BS4	1	0	0
I2C Available			

Contact

Print

SPECIFICATIONS

Item	Specifications	Unit
	UVE25-AW66D	
Input Frequency Range	55.25~801.25	MHz
Output Frequency	45.75	MHz
Input Impedance	75	Ω
Supply Voltage	5	V
V.S.W.R.	VHF : 7 max., UHF : 7 max.	—
Noise Figure	VHF : 10 max., UHF : 10 max.	dB
Power Gain	VHF : 27 min., UHF : 29 min.	dB
Cross Modulation	VHF : 65min., UHF : 65 min.	dB
Tuning Curve	VL : 1.7~21.5, VH : 1.1~23.5, UHF : 1.4~26.0	V
Image Rejection	VHF : 50 min., UHF : 45 min.	dB
Gain Reduction	VHF : 35 min., UHF : 33 min.	dB
+B Drift	VHF : ± 70 , UHF : ± 70	kHz

*Note Specifications subject to change without notice.

ADDITIONAL VARIETY IN UVE25 SERIES

Model	Band	Receiving Channel	IF (MHz)	Standard Voltage	Certification
UVE25-AW66D	U.S.A.	VL (2~Bch), VH (C~W+11ch) UHF (W+12~69ch)	45.75	+B=5.0V, AGC=4V	FCC, UL

DIMENSIONS

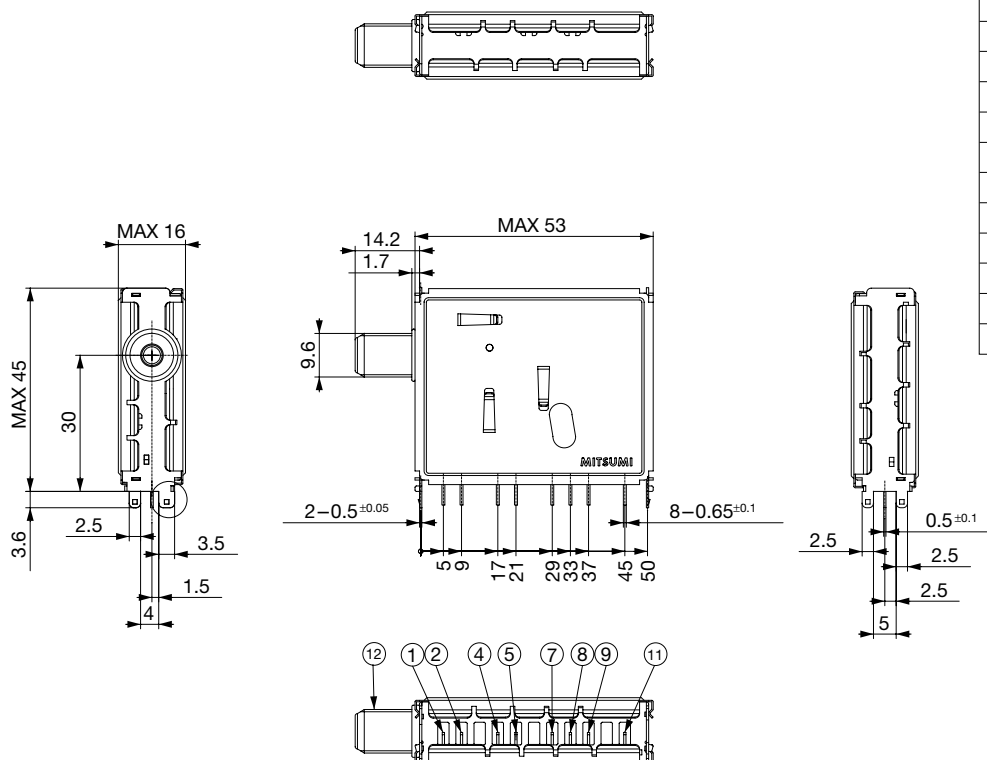

Terminals
1. AGC
2. VT
3. —
4. SCL
5. SDA
6. —
7. BP
8. N.C.
9. BT
10. —
11. IF
12. VHF-UHF IN

Unit : mm
General Tolerance : ± 0.5 mm

SPECIFICATIONS

Item	Specifications	Unit
	UVE25-EW65D	
Input Frequency Range	45.25~855.25	MHz
Output Frequency	38.9	MHz
Input Impedance	75	Ω
Supply Voltage	5	V
V.S.W.R.	VHF : 6, UHF : 6 max.	—
Noise Figure	VHF : 10 max., UHF : 10 max.	dB
Power Gain	VHF : 28 min., UHF : 27 min.	dB
Cross Modulation	VHF : 75, UHF : 75 min.	dB
Tuning Curve	VHF : 1.5~25, UHF : 1~24	V
Image Rejection	VHF : 50, UHF : 45 min.	dB
Gain Reduction	VHF : 45, UHF : 33 min.	dB
+B Drift	VHF : ± 70 , UHF : ± 70 max.	kHz

*Note Specifications subject to change without notice.

ADDITIONAL VARIETY IN UVE25 SERIES

Model	Band	Receiving Channel	IF(MHz)	Standard Voltage
UVE25-EW65D	HYPER	VHF(N1~S6, S7~S36ch) UHF(S37~69ch)	38.9	+B=5.0V, AGC=4V
UE25-B59D	UK	UHF(21~69ch)	39.5	+B=5.0V, AGC=4V

DIMENSIONS

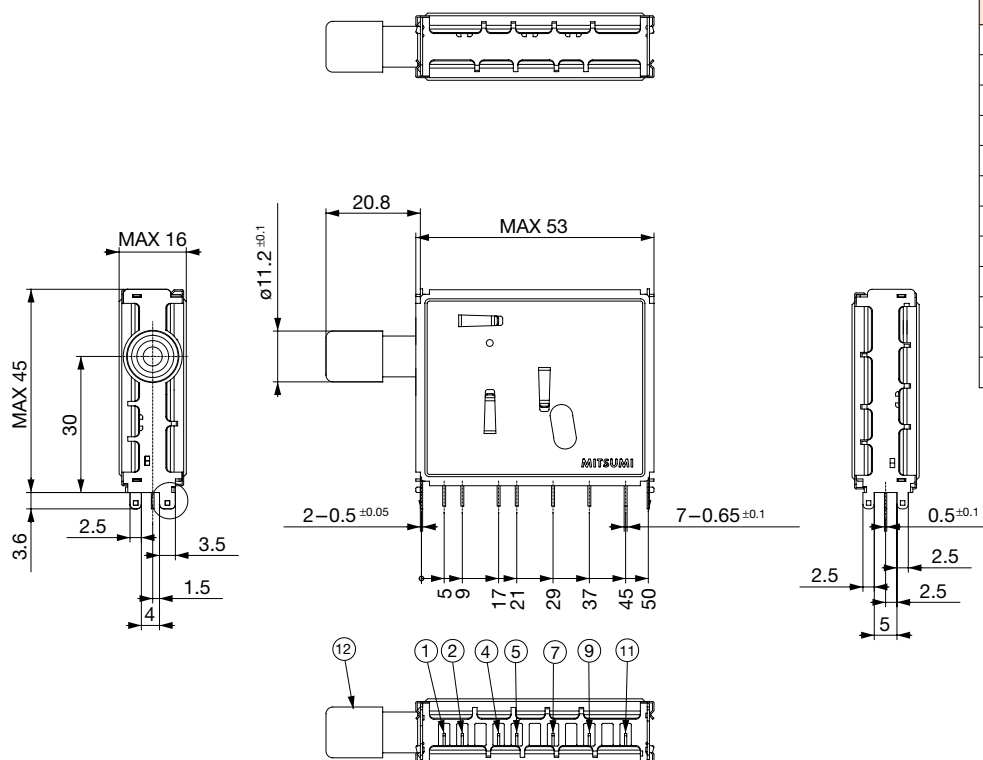

Terminals
1. AGC
2. (VT)
3. —
4. SCL
5. SDA
6. —
7. BP
8. —
9. BT
10. —
11. IF
12. VHF-UHF IN

Unit : mm
General Tolerance : ± 0.5 mm

DIMENSIONS

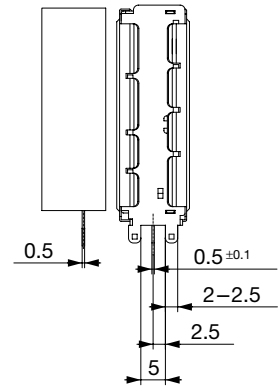
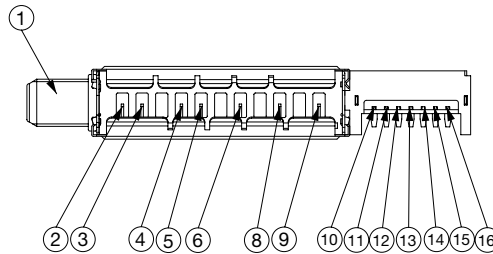
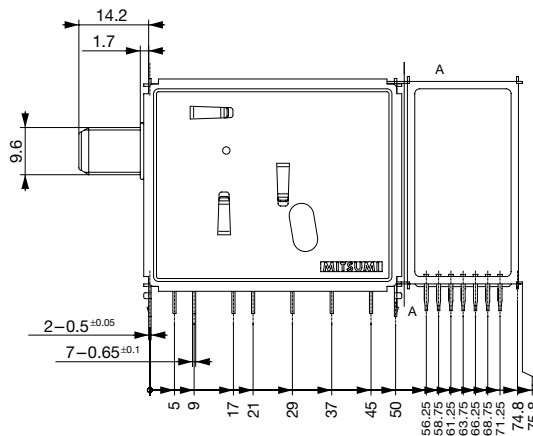
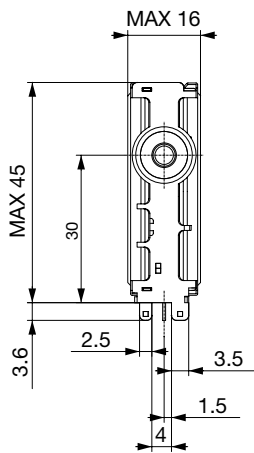

A-A Cross Section

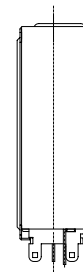

Terminals	
1.	VHF-UHF IN
2.	AGC IN
3.	(VT)
4.	SCL
5.	SDA
6.	BP (5V)
7.	—
8.	BT
9.	IF OUT
10.	IF-IN
11.	+B (5V)
12.	AGC OUT
13.	AUDIO OUT
14.	—
15.	VIDEO OUT
16.	GND

Unit : mm
General Tolerance : ±0.5mm

*For the technical details of the products in this page, please refer to Sales Technique Dept., AVC Business Division, Phone: 0462 (30) 3480.

ADDITIONAL VARIETY IN UVE25 SERIES

Model	Band	Receiving Channel	IF(MHz)	Standard Voltage	Shape
UVE25-JW60D	JAPAN	VHF(1~C22, 4~C52ch) UHF(C53~62ch)	58.75	+B=5.0V, AGC=5V	Standing Type
UVE25-JW61D	JAPAN	VHF(1~C22, 4~C52ch) UHF(C53~62ch)	58.75	+B=5.0V, AGC=5V	Standin Type With Splitter
UVE25-JW57D	JAPAN	VHF(1~C22, 4~C52ch) UHF(C53~62ch)	58.75	+B=5.0V, AGC=5V	Horizontal Type

DIMENSIONS

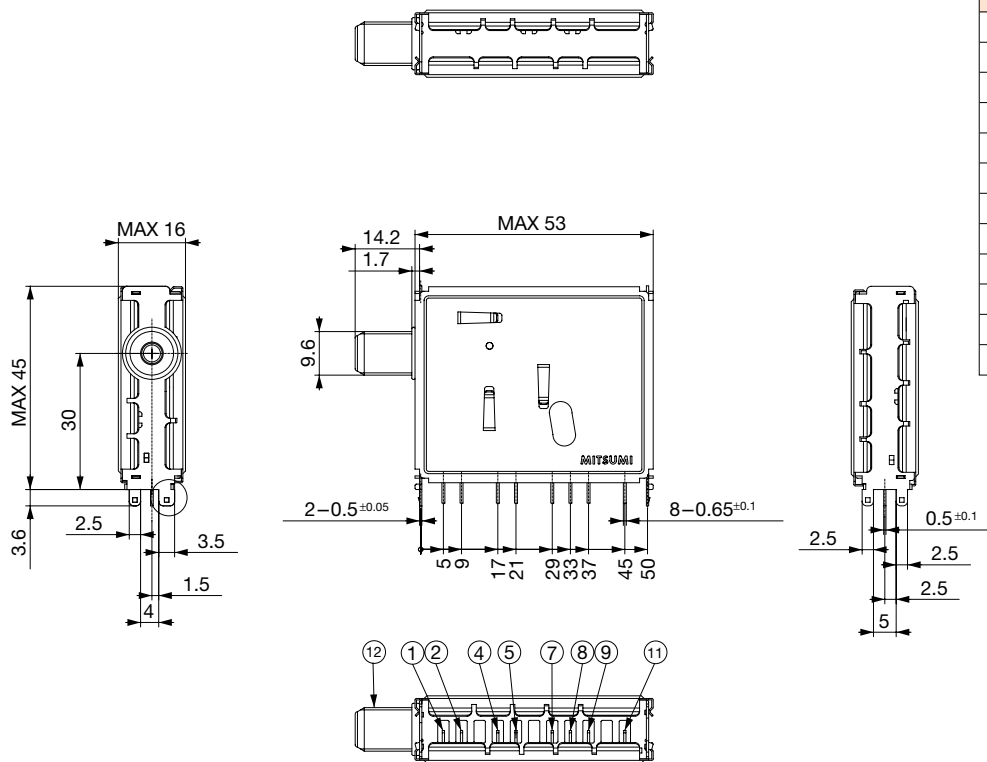

Terminals
1. AGC
2. VT
3. —
4. SCL
5. SDA
6. —
7. BP
8. N.C.
9. BT
10. —
11. IF
12. VHF-UHF IN

Unit : mm
General Tolerance : ±0.5mm

*For the technical details of the products in this page, please refer to Sales Technique Dept., AVC Business Division, Phone: 0462 (30) 3480.

Dimensions

Unit:mm

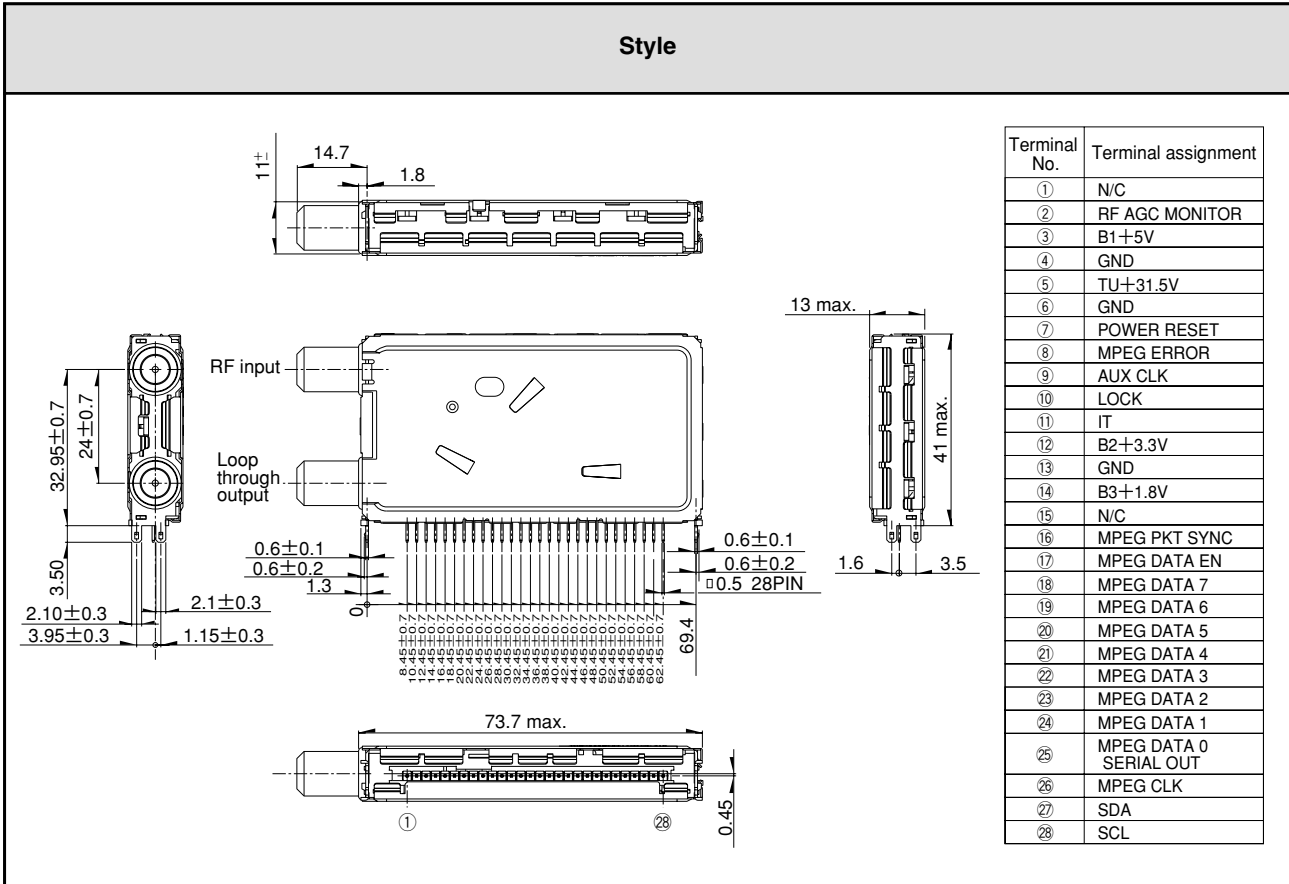

CAUTION

- 1.The appearance and specifications of the product may be modified without prior notice to improve its performance.
- 2.This catalog shows only outline specifications. When using the product, please obtain formal specifications for supply.
- 3.This catalog is valid till the end of December 2003.
- 4.All products and brand names provided in this catalog are trademarks or registered trademarks of their respective owners.

Key benefits listing

- Pre-amplifier
- Band-pass filter
- Input filter

Pre-amplifier

Dual gate MOSFETs

Product family	Key parameters	Key benefits
BF9 / BF11 / BF12	Noise figure, V _{DS}	Technology leader in dual gate MOSFETs Full, partial and external biasing possible Specific types optimized for VHF-low, VHF-high and UHF

Varicap diodes

Product family	Key parameters	Key benefits
Varicap diodes	Capacitance ratio, Range of diode capacitance	All TV varicap diodes are matched within reel Specific types optimized for VHF-low, VHF-high and UHF

Band-pass filter

Product family	Key parameters	Key benefits
Varicap diodes	Capacitance ratio, Range of diode capacitance	All TV varicap diodes are matched within reel Specific types optimized for VHF-low, VHF-high and UHF

Input filter

Product family	Key parameters	Key benefits
Varicap diodes	Capacitance ratio, Range of diode capacitance	All TV varicap diodes are matched within reel Specific types optimized for VHF-low, VHF-high and UHF

BLOCK DIAGRAM

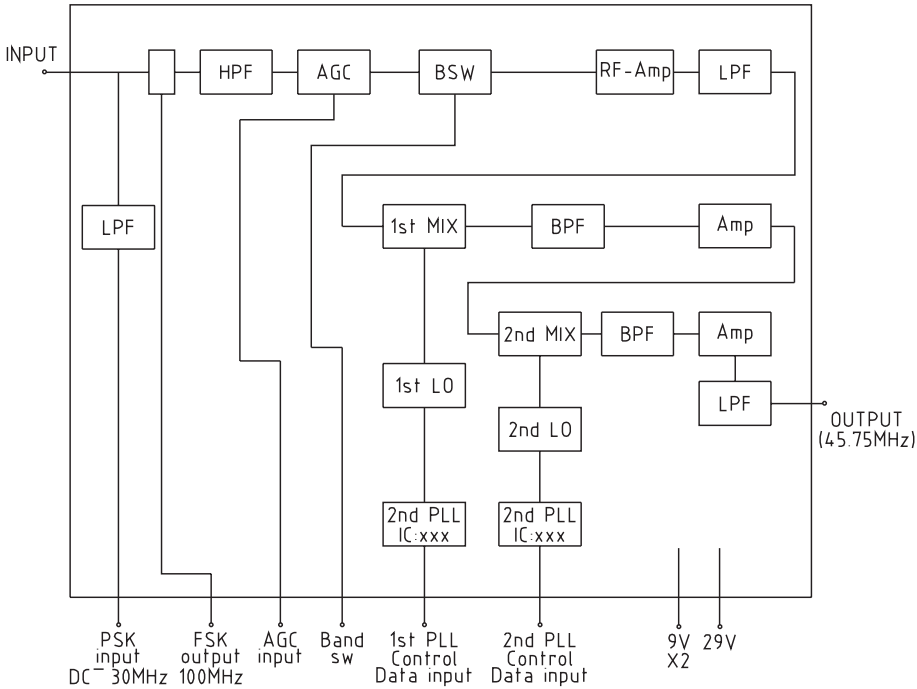

DIMENSIONS

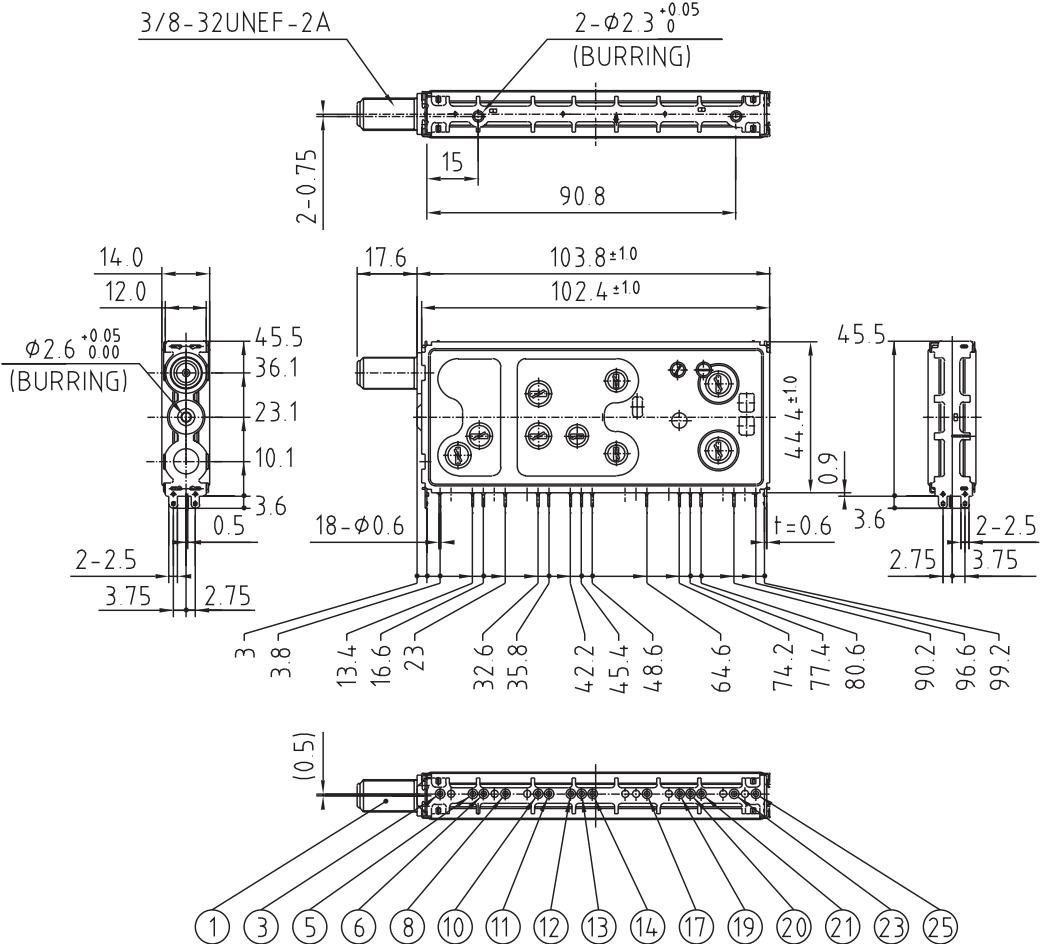

Terminals	
1.	RF IN
2.	_____
3.	PSK IN
4.	FSK OUT
5.	BAND SW
6.	AGC
7.	_____
8.	30V (VT)
9.	_____
10.	9V
11.	LOCK-1
12.	RST-1 (ENABLE)
13.	CPS-1 (CLOCK)
14.	SI-1 (DATE)
15.	_____
16.	_____
17.	LOCK-2
18.	_____
19.	RST-2 (ENABLE)
20.	CPS-2 (CLOCK)
21.	SI-2 (DATE)
22.	_____
23.	9V
24.	_____
25.	IF OUT

General Tolerance : ±0.5mm
Unit : mm

BLOCK DIAGRAM

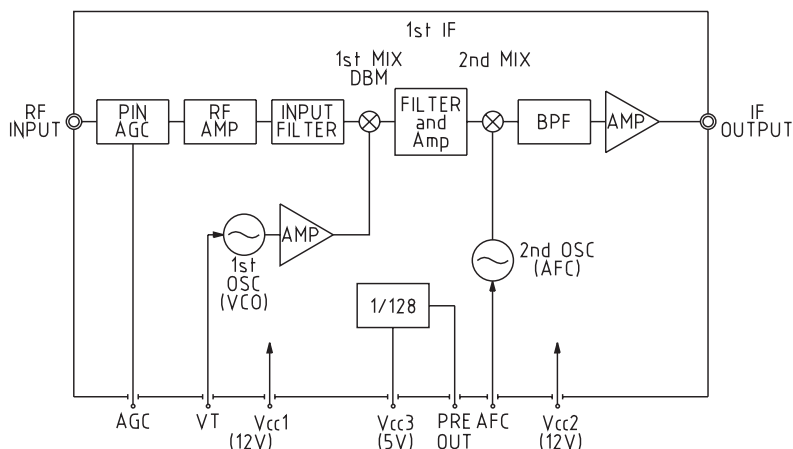

DIMENSIONS

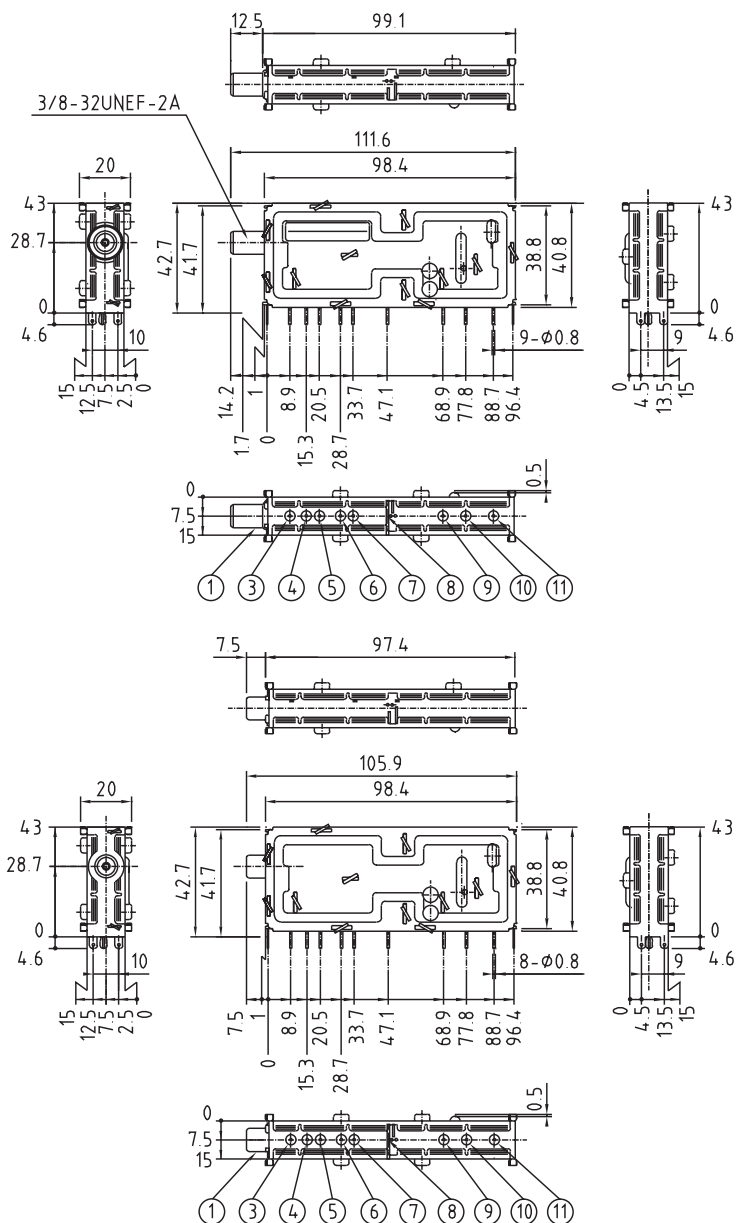

Terminals	
1.	Signal Input
2.	—
3.	AGC
4.	VT (+1~+27V)
5.	Vcc 1 (+12V)
6.	Vcc 3 (+5V)
7.	Prescaler Output
8.	GND
9.	AFC (+6V)
10.	Vcc 2 (+12V)
11.	Signal Output

General Tolerance : ±0.5mm
Unit : mm

Supply Voltage

Unit:V

Terminal	Supply voltage
MB (PB)	5
AGC	4.0~0
TU2	32

Dimensions

Unit:mm

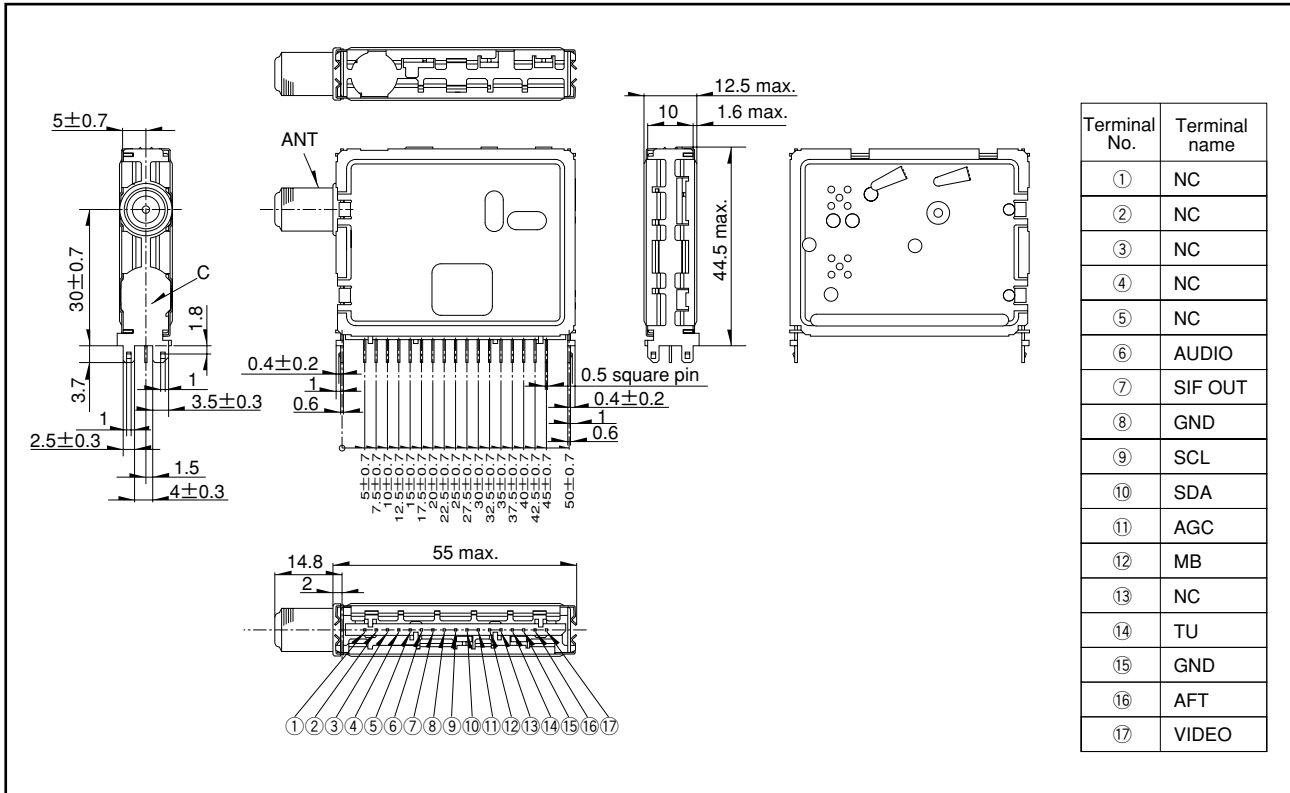

CAUTION

- 1.The appearance and specifications of the product may be modified without prior notice to improve its performance.
- 2.This catalog shows only outline specifications. When using the product, please obtain formal specifications for supply.
- 3.This catalog is valid till the end of December 2003.
- 4.All products and brand names provided in this catalog are trademarks or registered trademarks of their respective owners.

Sintonizador

Informações sobre Equivalência entre Sintonizadores Varicaps 181 CH

Para os modelos **HPS 14R HPS 1481 HPS 2081**

Os sintonizadores **Mitsumi UVE 50-AW74** ou **UVE 50-AW82D** e **Samsung TEECC1080** ou **TEEBC1880** são idênticos e o **pino 8** do **IC 701** deve estar conectado ao **terra** através do jumper JC62.

TUGH8EF82M e **Daewoo DT9-NF02F** são idênticos e o **pino 8** do **IC 701** deve estar conectado ao **Vcc** através do jumper JC63.

Nota: Na substituição de um sintonizador pelo outro basta verificar o **pino 8** do microcontrolador **IC 701**.

Para os modelos **HPS 2181 HPS 2781 HPS 2981**

Usar somente o **TUGHEF82M** ou **Daewoo DT9-NF02F** outro tipo não é compatível pois, o micro não fornece a opção de mudança de protocolo.

Modelos **HPS 1415 / 1430 / 1450 / 2015 / 2025 / 2050 / 2065 / 2070 / 2080 / 2085 / 2090 / 2095 / 3350**

Utilizam dois tipos de seletores que são intercambiáveis e portanto compatíveis. Apesar de um possuir entrada 75 ohms mixada U/V e o outro duas entradas independentes sendo uma de 75 V e a outra 300 U, funcionam perfeitamente um no lugar do outro.

Para os modelos **HPS1491/ HPS2091, HPS20VR, HPS2990 e HPS3380**

Utilizam dois tipos de sintonizadores porem equivalentes entre si, são eles: Tuner Sanyo 115-B-6085AP, Tuner VTSS7USZPLD, Alps CHR7A707B

Para os modelos **HPS1401 / 2001 / 1492 / 2092**

Utilizam dois tipos de sintonizadores que são configurados o data e clock configurado na e2pron do aparelho (ver menu de serviços) e, que dependendo circuito pode ser ou não intercambiáveis:

O modelo Alps usa alimentação auxiliar de 9 volts e a de 5 volts normal.

O modelo Philips não usa a alimentação de 9 volts somente a de 5 volts mas, se tiver a alimentação de 9 não tem problema funciona normalmente.

Para os modelos **HPS1402 / 1403 / 1404 / 2002 / 2003 / 2004 / 2005 / 2006**

Utilizam varios tipos de sintonizadores compatíveis desde que configurados corretamente conforme tabela abaixo, juntamente com o data e clock configurado na e2pron do aparelho (ver menu de serviços).

PROTOCOLO TUNERS	
TUNER	IC701-PINO 33
PHILLPS	5V
PANASONIC	5V
SANSUNG	5V
DAEWOO	5V
ALPS	GND
MITSUMI	GND
THONSON	GND