

# MCP41XXX/42XXX

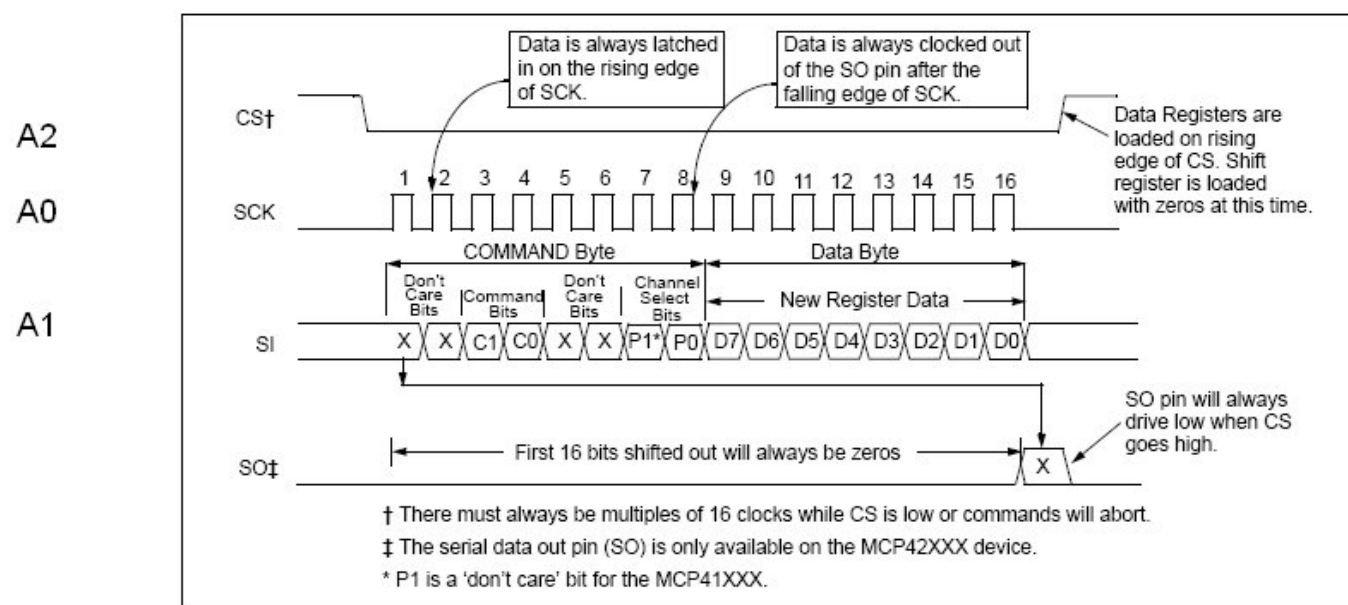

FIGURE 5-1: Timing Diagram for Writing Instructions or Data to a Digital Potentiometer.

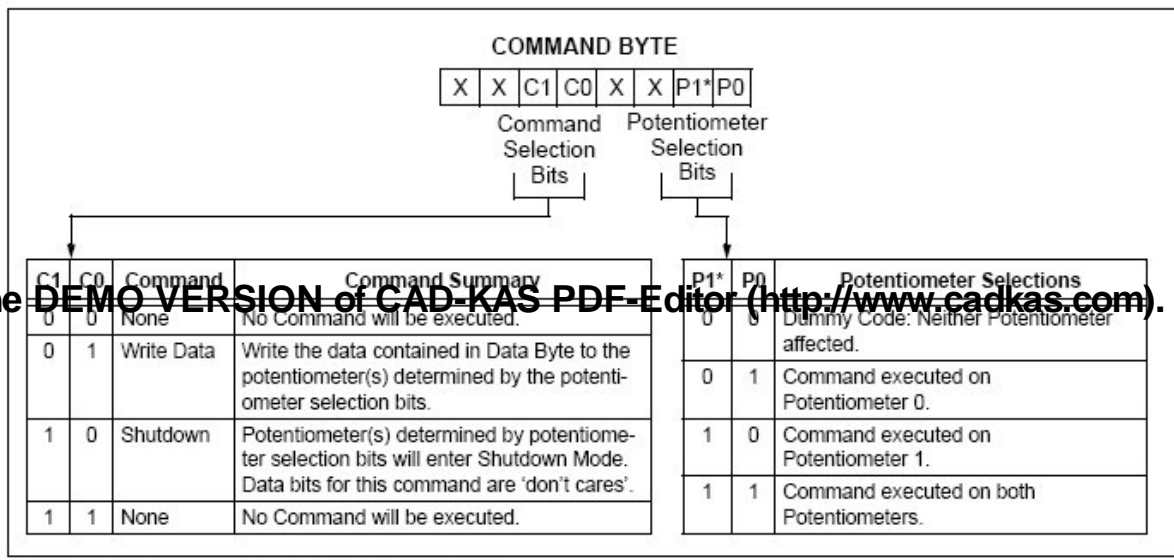

FIGURE 5-2: Command Byte Format.

