

APC220-43

13dBm ISM RF Transceiver Module

V1.03

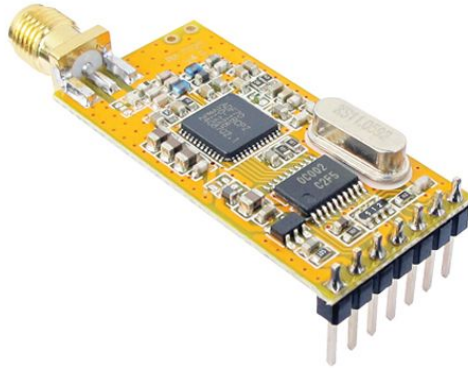

Features

- 1000m of communication distance (2400bps)
- GFSK Modulation
- 418MHz to 455MHz, 470MHz to 510MHz ISM frequency band
- More than 100 channels
- 13dBm Max. output power
- High efficient looped interleaving EDAC
- RS485/RS232/UART interface
- Dual 256bytes data buffer

Application

- Industrial automation
- Security alarm
- Telemetry
- Automatic meter reading
- Oil and gas detection
- Wire replacement
- Remote control and monitoring
- Wireless sensor network

DESCRIPTION

APC220-43 is a sub-1 GHz transceiver module designed for operations in the unlicensed ISM (Industrial Scientific Medical) and LPRD bands. GFSK (Frequency Shift Keying) modulation/demodulation, multi-channel operation, high bandwidth efficiency and anti-blocking performance make APC220-43 modules easy to realize the robust and reliable wireless link.

PIN FUNCTIONS

PIN	Name	Description
1	GND	Ground (0V)

2	VCC	Power supply. DC 3.3V-5.5V
3	EN	Power enable, $\cong 1.6V$ or empty, $\cong 0.5V$ sleep
4	RXD	UART input, TTL level
5	TXD	UART output, TTL level
6	AUX	The pin is expanded for other functions
7	SET	Setting parameters, setting online supported
8	NC	Not connected
9	NC	Not connected

Table 1: APC220-43 Pin Functions

ELECTRICAL SPECIFICATIONS

Symbol	Parameter (condition)	Min.	Typ.	Max.	Units
VCC	Supply Voltage	3.5		5.5	V
Temp	Operating temperature range	-30	25	85	°C
RH	Operating relative humidity	10		90	%
Freq	Frequency range	418		455	MHz
FDEV	Modulation deviation		28.8		KHz
Mod	Modulation type		GFSK		
IDD	Receive mode			28	mA
	Transmit mode @ 20mW			40	mA
	Sleep mode			5	uA
Pout	Output power			13	dBm
Sen	Receiving sensitivity @9.6K bps		-117		dBm
DRFSK	Air data rate	2.4	9.6	19.2	Kbps
DRIN	UART data rate	1.2		57.6	Kbps
TS	Switching time		5		us
CHBW	Channel spacing		200		kHz
ZANT	Antenna Impedance		50		Ohm

Table 2: APC220-43 Electrical Specifications

SETTING PARAMETERS

1. DEFAULT VALUES

Parameter	Option	Default Value	Units
UART data rate	1.2, 2.4, 4.8, 9.6, 19.2, 38.4, 57.6	9.6	Kbps
Parity Check	No check, Even parity, Odd parity	No check	Disable
Frequency	418MHz ~ 455MHz (1KHz per step)	433.92	MHz
Air data rate	2.4, 4.8, 9.6, 19.2	9.6	Kbps
Output Power	0 ~ 9 levels	9 (20mW)	mW

Table 3: APC220-43 Default Settings

2. PARAMETER SETTING

Users can configure the parameters (frequency, data rate, output power, etc.) of RF modules by PC or MCU.

BY PC . The interface of APC220-43 is UART/TTL. If connecting it to PC, users need to use a converter to transform the different levels. APPCON provides two types converter boards (TTL-to-RS232 and TTL-to-USB) for configuration.

Firstly users need to insert module into converter board and connect converter board to PC by cable, then open APPCON RF-Magic software. After that the status column of software should display “Found Device”. Users then can read/write the module.

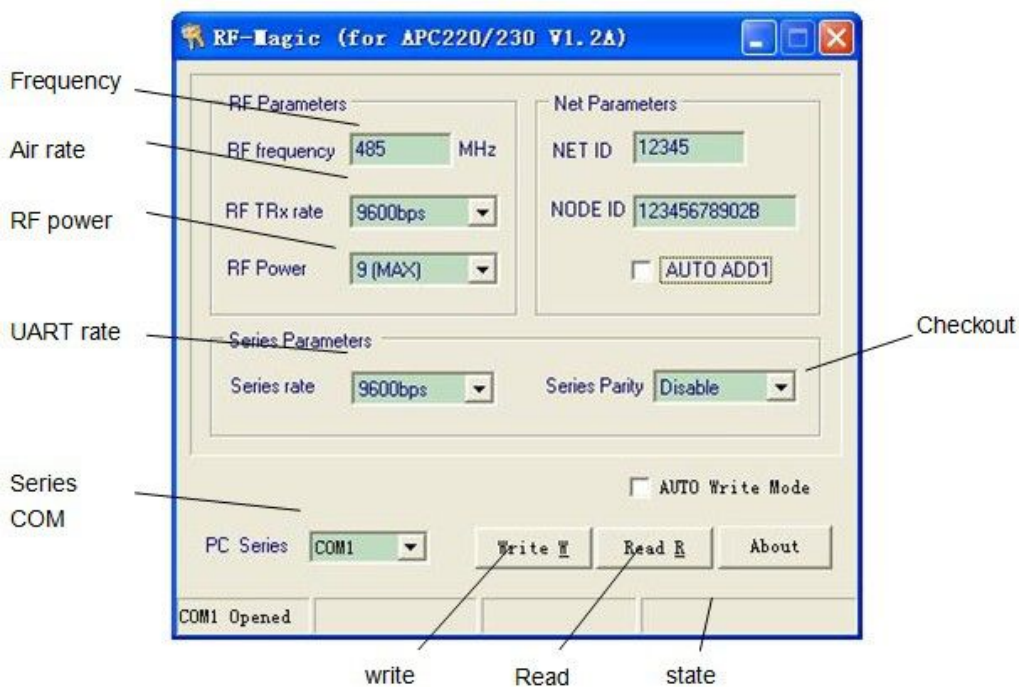

Figure 1: APPCON RF-Magic

BY MCU . The parameters are set by TTL/UART (4,5PIN) and the control pin of SET(see the Figure 2), The module can work normally 50ms (T1) after powering on. When configuring the module, users need to switch the SET pin to low and the module then enters into setting mode after 1ms or more (T2). It will use 9600 bps (UART data rate) and no parity check as default format to communicate.

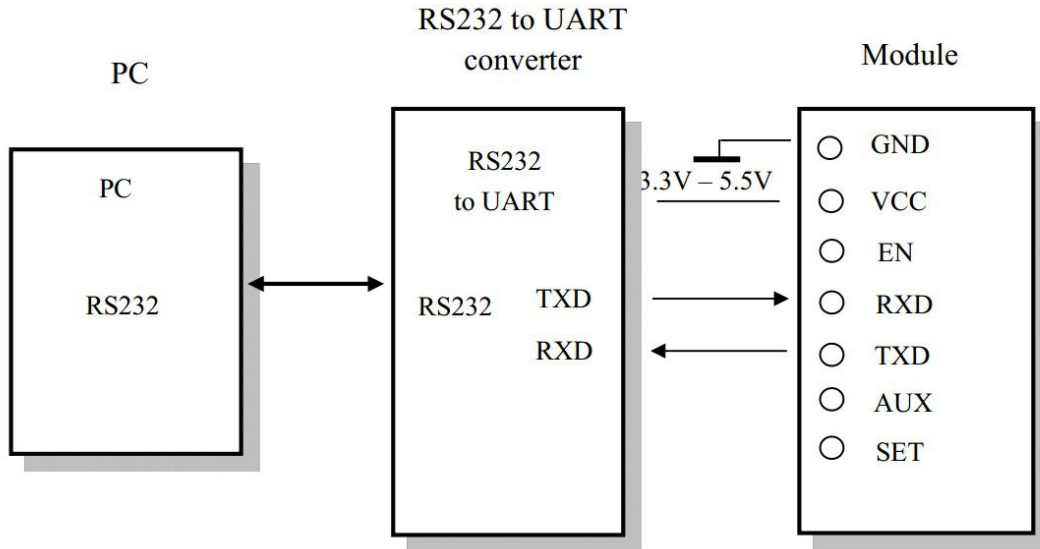

Figure 2: Connecting Diagram

When a command is sent to the module through the RXD pin, the module will send back response information by TXD pin in 200ms after it verifies the command is correct. When users check out the parameters are successfully set from the response information, the SET pin can be set to high and the module will work with the new settings in 10ms (T4).

Please note that users can only send command once when the SET pin is configured to low. If users want to revise the parameters after a successful setting, users must configure SET pin to high and then set it into low in order to reconfigure the module. After 100ms (T4), the module will work with the new parameters.

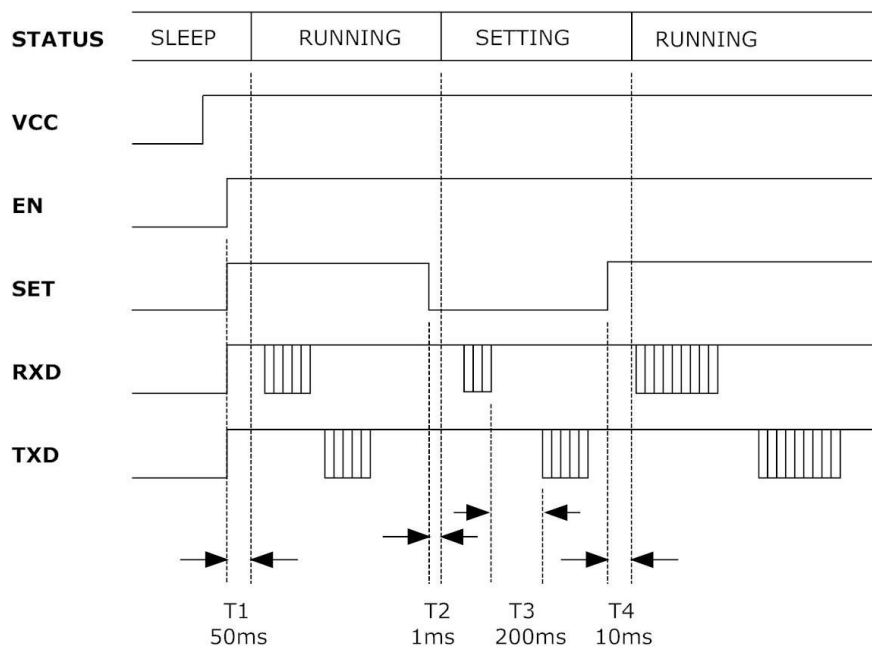

Figure 3: Timing Sequence for Setting Parameters

The commands of APC220-43 are ASCII coding. The default configuring data rate is 9600 bps and no parity check included. The command set include two commands: Read command and Write command.

Read command: *RD ✓*

Response (from module): PARA_frequency_rf data_rate_output power_UART data_rate_series checkout ✓

Write command: *WR_frequency_RF data_rate_output power_UART rate_series_check ✓*

Response (from module): PARA_frequency_rf data_rate_output power_UART data_rate_series checkout ✓

The Parameters Table

Parameter	Unit	Length(Bytes)	Explanation
Freq.	KHz	6	433.92MHz = 433920
DRFSK	Kbps	1	2400, 4800, 9600, 19200 bps equal to 1, 2,3, 4
POUT	dBm	1	0~9; 0 refers to -1dBm and 9 for 13dBm
DRIN	Kbps	1	1.2, 2.4, 4.8, 9.6, 19.2, 38.4, 57.6 equal to 0,1, 2, 3, 4, 5, 6
Parity	---	1	0: No parity; 1: Even parity; 2: Odd parity

Table 4: APC220-43 Parameter Coding

E.g. If the user wants to set the module work at Freq (434MHz), DR FSK (9.6k bps), POUT (20mW), DRIN (1.2K bps) and Parity (no parity), the command could be written as below:

Write Command: *WR_434000_3_9_0_0 ✓*

Corresponding HEX code: 0x57,0x52,0x20,0x34,0x33,0x34,0x30,0x30,0x30,0x20,0x33,0x20,0x39,0x20,0x30,0x20,0x30,0x0D,0x0A ✓

Response: *PARA_434000_3_9_0_0 ✓*

Corresponding HEX code: 0x50,0x41,0x52,0x410x20,0x34,0x33,0x34,0x30,0x30,0x30,0x20,0x33,0x20,0x39,0x20,0x30,0x20,0x30,0x0D,0x0A ✓

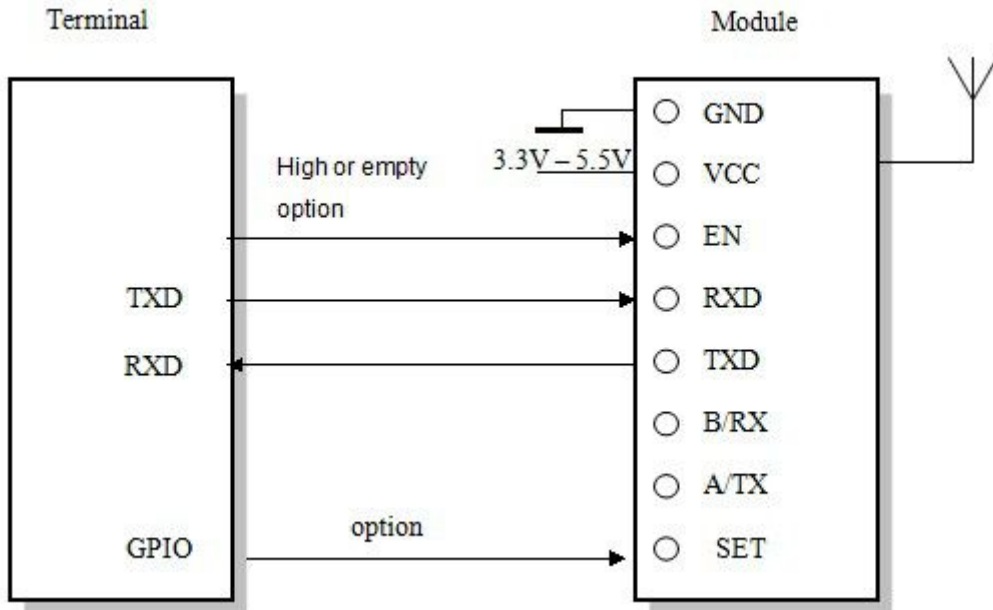

Figure 4: The Connection between Module and Terminal

APPLICATION NOTES

APC220-43 series are half-duplex wireless modules which can be used in point-to-point or point-to-multi-point applications. In the latter application, users need to set one module as the host and others as client modules. Each module must have an unique ID and the coordination of communication is controlled by the host which send data and commands including ID. If the client module finds that the ID contained in the received message is the same as its own, it will continue to receive the remaining data; otherwise it will discard the coming message. In order to avoid any interference, only one module is allowed to work in transmitting mode at any time. APC220-43 can set many different frequencies so that many networks can work in the same place and at the same time.

MECHANICAL DATA

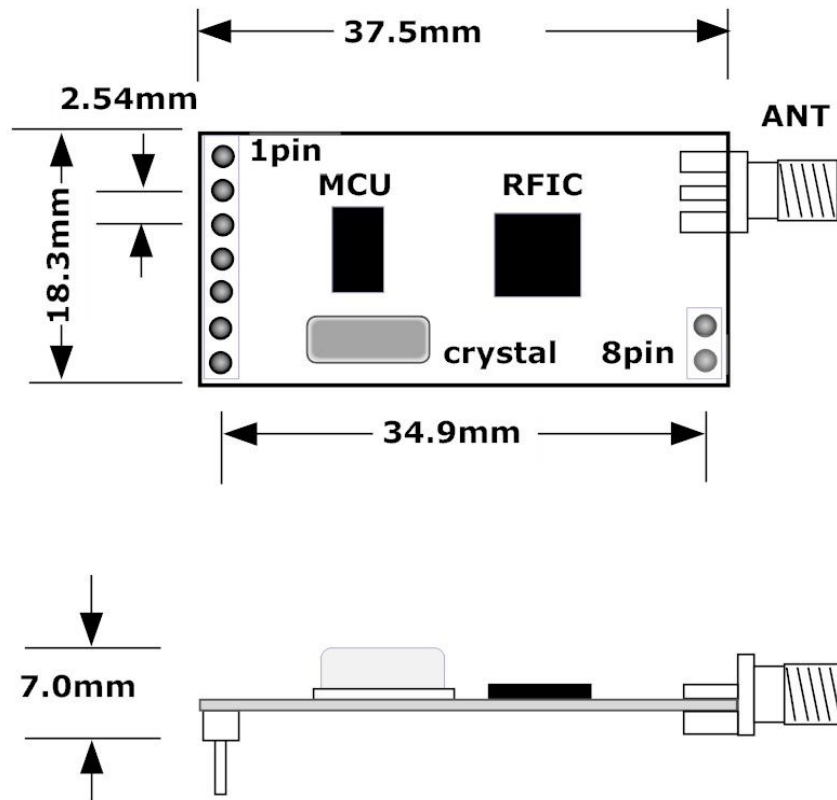

Figure 5: Mechanical Dimension