

Understanding Buck-Boost Power Stages in Switch Mode Power Supplies

Everett Rogers

System Power

ABSTRACT

A switching power supply consists of the power stage and the control circuit. The power stage performs the basic power conversion from the input voltage to the output voltage and includes switches and the output filter. This report addresses the buck-boost power stage only and does not cover control circuits. Detailed steady-state and small-signal analysis of the buck-boost power stage operating in continuous and discontinuous mode is presented. Variations in the standard buck-boost power stage and a discussion of power stage component requirements are included.

Contents

1	Introduction	2
2	Buck-Boost Stage Steady-State Analysis	3
2.1	Buck-Boost Steady-State Continuous Conduction Mode Analysis	3
2.2	Buck-Boost Steady-State Discontinuous Conduction Mode Analysis	7
2.3	Critical Inductance	11
3	Buck-Boost Power Stage Small Signal Modeling	12
3.1	Buck-Boost Continuous Conduction Mode Small-Signal Analysis	13
3.2	Buck-Boost Discontinuous Conduction Mode Small-Signal Analysis	16
4	Variations of the Buck-Boost Power Stage	21
4.1	Flyback Power Stage	21
5	Component Selection	24
5.1	Output Capacitance	24
5.2	Output Inductance	26
5.3	Power Switch	27
5.4	Output Diode	28
6	Summary	29
7	References	31

1 Introduction

The three basic switching power supply topologies in common use are the buck, boost, and buck-boost. These topologies are nonisolated, i.e., the input and output voltages share a common ground. There are, however, isolated derivations of these nonisolated topologies. The power supply topology refers to how the switches, output inductor, and output capacitor are connected. Each topology has unique properties. These properties include the steady-state voltage conversion ratios, the nature of the input and output currents, and the character of the output voltage ripple. Another important property is the frequency response of the duty-cycle-to-output-voltage transfer function.

The buck-boost is a popular nonisolated, inverting power stage topology, sometimes called a step-up/down power stage. Power supply designers choose the buck-boost power stage because the output voltage is inverted from the input voltage, and the output voltage can be either higher or lower than the input voltage. The topology gets its name from producing an output voltage that can be higher (like a boost power stage) or lower (like a buck power stage) in magnitude than the input voltage. However, the output voltage is opposite in polarity from the input voltage. The input current for a buck-boost power stage is discontinuous or pulsating due to the power switch (Q1) current that pulses from zero to I_L every switching cycle. The output current for a buck-boost power stage is also discontinuous or pulsating. This is because the output diode only conducts during a portion of the switching cycle. The output capacitor supplies the entire load current for the rest of the switching cycle.

This report describes steady state operation of the buck-boost converter in continuous-mode and discontinuous-mode operation with ideal waveforms given. The duty-cycle-to-output-voltage transfer function is given after an introduction of the PWM switch model.

Figure 1 shows a simplified schematic of the buck-boost power stage with a drive circuit block included. The power switch, Q1, is an n-channel MOSFET. The output diode is CR1. The inductor, L, and capacitor, C, make up the effective output filter. The capacitor ESR, R_C , (equivalent series resistance) and the inductor DC resistance, R_L , are included in the analysis. The resistor, R, represents the load seen by the power stage output.

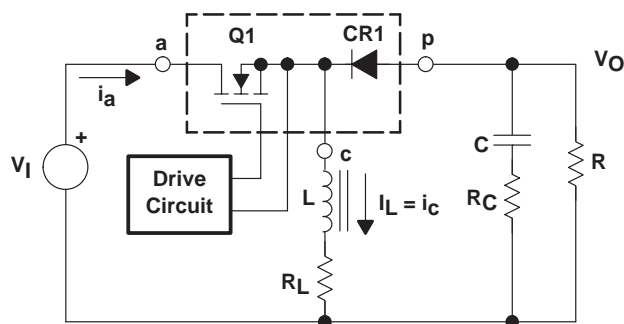

Figure 1. Buck-Boost Power Stage Schematic

During normal operation of the buck-boost power stage, Q1 is repeatedly switched on and off with the on- and off-times governed by the control circuit. This switching action gives rise to a train of pulses at the junction of Q1, CR1, and L. Although the inductor, L, is connected to the output capacitor, C, only when CR1 conducts, an effective L/C output filter is formed. It filters the train of pulses to produce a DC output voltage.

2 Buck-Boost Stage Steady-State Analysis

A power stage can operate in continuous or discontinuous inductor current mode. Continuous inductor current mode is characterized by current flowing continuously in the inductor during the entire switching cycle in steady-state operation. Discontinuous inductor current mode is characterized by the inductor current being zero for a portion of the switching cycle. It starts at zero, reaches a peak value, and returns to zero during each switching cycle. The two different modes are discussed in greater detail later and design guidelines for the inductor value to maintain a chosen mode of operation as a function of rated load are given. It is very desirable for a converter to stay in one mode only over its expected operating conditions because the power stage frequency response changes significantly between the two different modes of operation.

For this analysis, an n-channel power MOSFET is used and a positive voltage, $V_{GS(ON)}$, is applied from the Gate to the Source terminals of Q1 by the drive circuit to turn ON the FET. The advantage of using an n-channel FET is its lower $R_{DS(on)}$ but the drive circuit is more complicated because a floating drive is required. For the same die size, a p-channel FET has a higher $R_{DS(on)}$ but usually does not require a floating drive circuit.

The transistor Q1 and diode CR1 are drawn inside a dashed-line box with terminals labeled a, p, and c. This is explained fully in the *Buck-Boost Power Stage Modeling* section.

2.1 Buck-Boost Steady-State Continuous Conduction Mode Analysis

The following is a description of steady-state operation in continuous conduction mode. The main goal of this section is to provide a derivation of the voltage conversion relationship for the continuous conduction mode buck-boost power stage. This is important because it shows how the output voltage depends on duty cycle and input voltage or conversely, how the duty cycle can be calculated based on input voltage and output voltage. Steady-state implies that the input voltage, output voltage, output load current, and duty-cycle are fixed and not varying. Capital letters are generally given to variable names to indicate a steady-state quantity.

In continuous conduction mode, the buck-boost converter assumes two states per switching cycle. The ON State is when Q1 is ON and CR1 is OFF. The OFF State is when Q1 is OFF and CR1 is ON. A simple linear circuit can represent each of the two states where the switches in the circuit are replaced by their equivalent circuit during each state. The circuit diagram for each of the two states is shown in Figure 2.

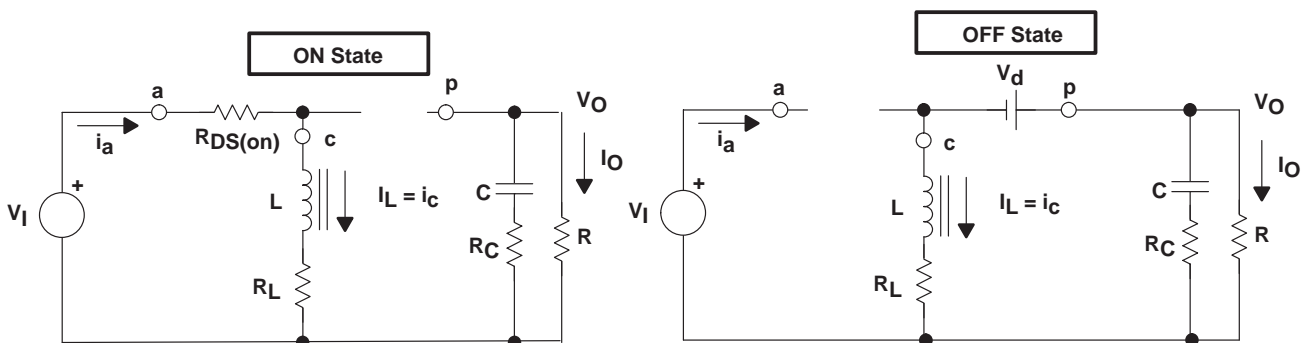

Figure 2. Buck-Boost Power Stage States

The duration of the ON state is $D \times T_S = T_{ON}$ where D is the duty cycle, set by the control circuit, expressed as a ratio of the switch ON time to the time of one complete switching cycle, T_S . The duration of the OFF state is called T_{OFF} . Since there are only two states per switching cycle for continuous conduction mode, T_{OFF} is equal to $(1-D) \times T_S$. The quantity $(1-D)$ is sometimes called D' . These times are shown along with the waveforms in Figure 3.

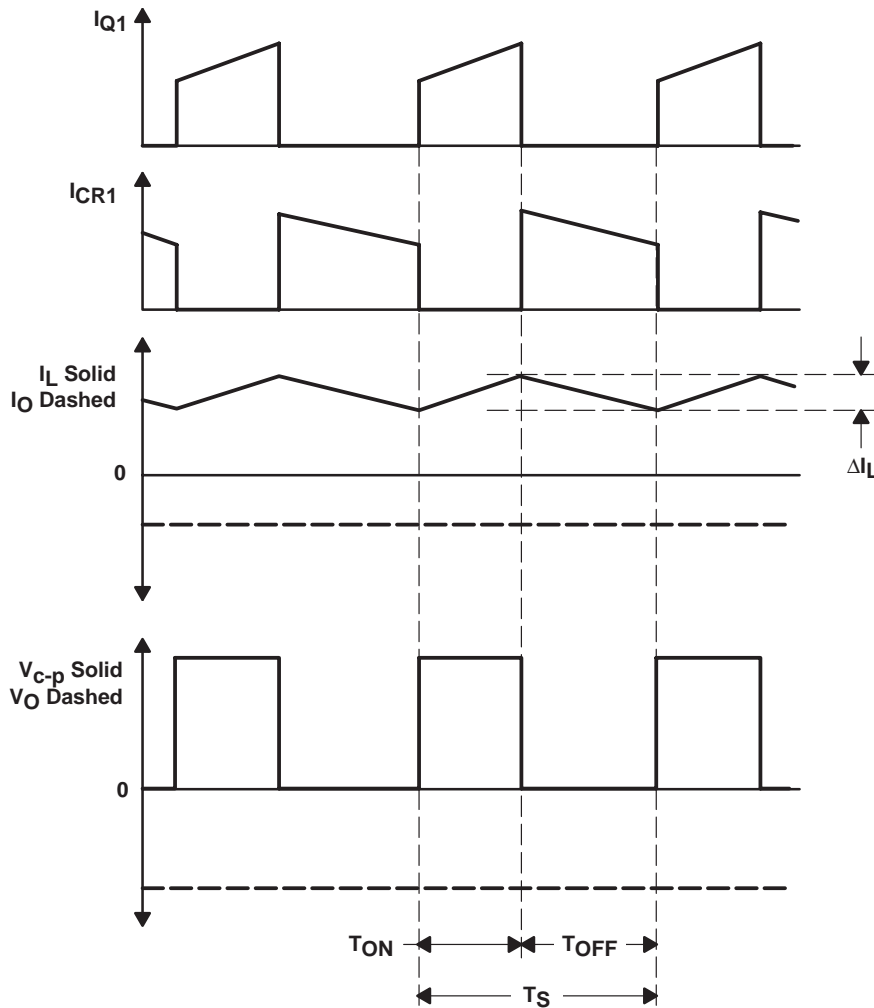

Figure 3. Continuous Mode Buck-Boost Power Stage Waveforms

Referring to Figure 2, during the ON state, Q1 presents a low resistance, $R_{DS(on)}$, from its drain to source and exhibits a small voltage drop of $V_{DS} = I_L \times R_{DS(on)}$. There is also a small voltage drop across the dc resistance of the inductor equal to $I_L \times R_L$. Thus, the input voltage, V_I , minus losses, $(V_{DS} + I_L \times R_L)$, is applied across the inductor, L. CR1 is OFF during this time because it is reverse biased. The inductor current, I_L , flows from the input source, V_I , through Q1 and to ground. During the ON state, the voltage applied across the inductor is constant and equal to $V_I - V_{DS} - I_L \times R_L$. Adopting the polarity convention for the current I_L shown in Figure 2, the inductor current increases as a result of the applied voltage. Also, since the applied voltage is essentially constant, the inductor current increases linearly. This increase in inductor current during T_{ON} is illustrated in Figure 3.

The amount that the inductor current increases can be calculated by using a version of the familiar relationship:

$$v_L = L \times \frac{di_L}{dt} \Rightarrow \Delta I_L = \frac{v_L}{L} \times \Delta T$$

The inductor current increase during the ON state is given by:

$$\Delta I_L(+)= \frac{V_I - (V_{DS} + I_L \times R_L)}{L} \times T_{ON}$$

This quantity, $\Delta I_L(+)$, is referred to as the inductor ripple current. Also notice that during this period, all of the output load current is supplied by the output capacitor, C.

Referring to Figure 2, when Q1 is OFF, it presents a high impedance from its drain to source. Therefore, since the current flowing in the inductor L cannot change instantaneously, the current shifts from Q1 to CR1. Due to the decreasing inductor current, the voltage across the inductor reverses polarity until rectifier CR1 becomes forward biased and turns ON. The voltage applied across L becomes $(V_O - V_d - I_L \times R_L)$ where the quantity, V_d , is the forward voltage drop of CR1. The inductor current, I_L , now flows from the output capacitor and load resistor combination through CR1 and to ground. Notice that the orientation of CR1 and the direction of current flow in the inductor means that the current flowing in the output capacitor and load resistor combination causes V_O to be a negative voltage. During the OFF state, the voltage applied across the inductor is constant and equal to $(V_O - V_d - I_L \times R_L)$. Maintaining our same polarity convention, this applied voltage is negative (or opposite in polarity from the applied voltage during the ON time), because the output voltage V_O is negative. Hence, the inductor current decreases during the OFF time. Also, since the applied voltage is essentially constant, the inductor current decreases linearly. This decrease in inductor current during T_{OFF} is illustrated in Figure 3.

The inductor current decrease during the OFF state is given by:

$$\Delta I_L(-)= \frac{-(V_O - V_d - I_L \times R_L)}{L} \times T_{OFF}$$

This quantity, $\Delta I_L(-)$, is also referred to as the inductor ripple current.

In steady state conditions, the current increase, $\Delta I_L(+)$, during the ON time and the current decrease during the OFF time, $\Delta I_L(-)$, must be equal. Otherwise, the inductor current would have a net increase or decrease from cycle to cycle which would not be a steady state condition. Therefore, these two equations can be equated and solved for V_O to obtain the continuous conduction mode buck-boost voltage conversion relationship:

Solving for V_O :

$$V_O = - \left[(V_I - V_{DS}) \times \frac{T_{ON}}{T_{OFF}} - V_d - I_L \times R_L \times \frac{T_{ON} + T_{OFF}}{T_{OFF}} \right]$$

And, substituting T_S for $T_{ON} + T_{OFF}$, and using $D = T_{ON}/T_S$ and $(1-D) = T_{OFF}/T_S$, the steady-state equation for V_O is:

$$V_O = - \left[(V_I - V_{DS}) \times \frac{D}{1-D} - V_d - \frac{I_L \times R_L}{1-D} \right]$$

Notice that in simplifying the above, $T_{ON} + T_{OFF}$ is assumed to be equal to T_S . This is true only for continuous conduction mode as we will see in the discontinuous conduction mode analysis.

An important observation should be made here: Setting the two values of ΔI_L equal to each other is precisely equivalent to *balancing the volt-seconds* on the inductor. The volt-seconds applied to the inductor is the product of the voltage applied and the time that the voltage is applied. This is the best way to calculate unknown values such as V_O or D in terms of known circuit parameters, and this method will be applied repeatedly in this paper. Volt-second balance on the inductor is a physical necessity and should be comprehended at least as well as Ohms Law.

In the above equations for $\Delta I_L (+)$ and $\Delta I_L (-)$, the output voltage was implicitly assumed to be constant with no AC ripple voltage during the ON time and the OFF time. This is a common simplification and involves two separate effects. First, the output capacitor is assumed to be large enough that its voltage change is negligible. Second, the voltage due to the capacitor ESR is also assumed to be negligible. These assumptions are valid because the AC ripple voltage is designed to be much less than the DC part of the output voltage.

The above voltage conversion relationship for V_O illustrates the fact that V_O can be adjusted by adjusting the duty cycle, D . This relationship approaches zero as D approaches zero and increases without bound as D approaches 1. A common simplification is to assume V_{DS} , V_d , and R_L are small enough to ignore. Setting V_{DS} , V_d , and R_L to zero, the above equation simplifies considerably to:

$$V_O = - V_I \times \frac{D}{1-D}$$

A simplified, qualitative way to visualize the circuit operation is to consider the inductor as an energy storage element. When Q1 is on, energy is added to the inductor. When Q1 is off, the inductor delivers some of its energy to the output capacitor and load. The output voltage is controlled by setting the on-time of Q1. For example, by increasing the on-time of Q1, the amount of energy delivered to the inductor is increased. More energy is then delivered to the output during the off-time of Q1 resulting in an increase in the output voltage.

Unlike the buck power stage, the average of the inductor current is not equal to the output current. To relate the inductor current to the output current, referring to Figures 2 and 3, note that the inductor delivers current to the output only during the off state of the power stage. This current averaged over a complete switching cycle is equal to the output current because the average current in the output capacitor must be equal to zero.

The relationship between the average inductor current and the output current for the continuous mode buck-boost power stage is given by:

$$I_{L(Avg)} \times \frac{T_{OFF}}{T_S} = I_{L(Avg)} \times (1 - D) = -I_O$$

or

$$I_{L(Avg)} = \frac{-I_O}{(1 - D)}$$

Another important observation is that the average inductor current is proportional to the output current, and since the inductor ripple current, ΔI_L , is independent of output load current, the minimum and the maximum values of the inductor current track the average inductor current exactly. For example, if the average inductor current decreases by 2 A due to a load current decrease, then the minimum and maximum values of the inductor current decrease by 2 A (assuming continuous conduction mode is maintained).

The forgoing analysis was for the buck-boost power stage operation in continuous inductor current mode. The next section is a description of steady-state operation in discontinuous conduction mode. The main result is a derivation of the voltage conversion relationship for the discontinuous conduction mode buck-boost power stage.

2.2 Buck-Boost Steady-State Discontinuous Conduction Mode Analysis

We now investigate what happens when the load current is decreased and the conduction mode changes from continuous to discontinuous. Recall for continuous conduction mode, the average inductor current tracks the output current, i.e. if the output current decreases, then so does the average inductor current. In addition, the minimum and maximum peaks of the inductor current follow the average inductor current exactly.

If the output load current is reduced below the critical current level, the inductor current will be zero for a portion of the switching cycle. This should be evident from the waveforms shown in Figure 3, since the peak to peak amplitude of the ripple current does not change with output load current. In a buck-boost power stage, if the inductor current attempts to fall below zero, it just stops at zero (due to the unidirectional current flow in CR1) and remains there until the beginning of the next switching cycle. This operating mode is called discontinuous conduction mode. A power stage operating in discontinuous conduction mode has three unique states during each switching cycle as opposed to two states for continuous conduction mode. The inductor current condition where the power stage is at the boundary between continuous and discontinuous mode is shown in Figure 4. This is where the inductor current just falls to zero and the next switching cycle begins immediately after the current reaches zero. Note that the absolute values of I_O and $I_{O(Crit)}$ are shown in Figure 4 because I_O and I_L have opposite polarities.

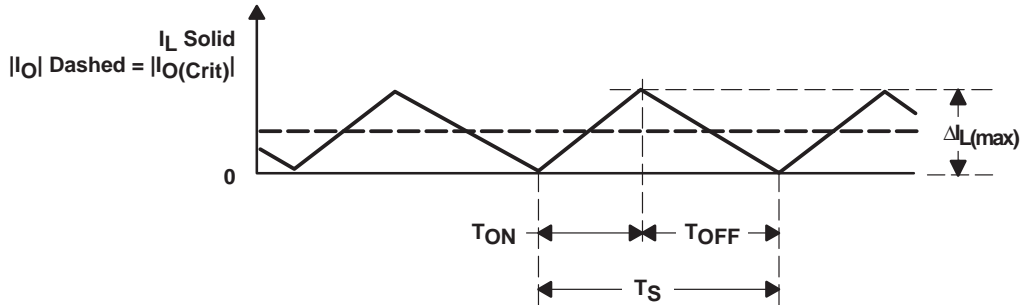

Figure 4. Boundary Between Continuous and Discontinuous Mode

Further reduction in output load current puts the power stage into discontinuous conduction mode. This condition is illustrated in Figure 5. The discontinuous mode power stage frequency response is quite different from the continuous mode frequency response and is given in the Buck-Boost Power Stage Modeling section. Also, the input to output relationship is quite different as shown in the following derivation.

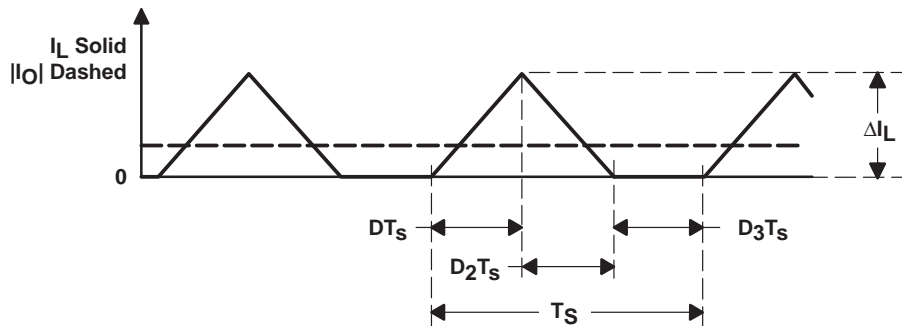

Figure 5. Discontinuous Current Mode

To begin the derivation of the discontinuous conduction mode buck-boost power stage voltage conversion ratio, recall that there are three unique states that the converter assumes during discontinuous conduction mode operation. The ON State is when Q1 is ON and CR1 is OFF. The OFF State is when Q1 is OFF and CR1 is ON. The IDLE state is when both Q1 and CR1 are OFF. The first two states are identical to those of the continuous mode case and the circuits of Figure 2 are applicable except that $T_{OFF} \neq (1-D) \times T_S$. The remainder of the switching cycle is the IDLE state. In addition, the DC resistance of the output inductor, the output diode forward voltage drop, and the power MOSFET ON-state voltage drop are all assumed to be small enough to omit.

The duration of the ON state is $T_{ON} = D \times T_S$ where D is the duty cycle, set by the control circuit, expressed as a ratio of the switch ON time to the time of one complete switching cycle, T_S . The duration of the OFF state is $T_{OFF} = D_2 \times T_S$. The IDLE time is the remainder of the switching cycle and is given as $T_S - T_{ON} - T_{OFF} = D_3 \times T_S$. These times are shown with the waveforms in Figure 6.

Without going through the detailed explanation as before, the equations for the inductor current increase and decrease are given below.

The inductor current increase during the ON state is given by:

$$\Delta I_L(+)=\frac{V_I}{L}\times T_{ON}=\frac{V_I}{L}\times D\times T_S=I_{PK}$$

The ripple current magnitude, $\Delta I_L(+)$, is also the peak inductor current, I_{PK} because in discontinuous mode, the current starts at zero each cycle.

The inductor current decrease during the OFF state is given by:

$$\Delta I_L(-)=\frac{-V_O}{L}\times T_{OFF}=\frac{-V_O}{L}\times D_2\times T_S$$

As in the continuous conduction mode case, the current increase, $\Delta I_L(+)$, during the ON time and the current decrease during the OFF time, $\Delta I_L(-)$, are equal. Therefore, these two equations can be equated and solved for V_O to obtain the first of two equations to be used to solve for the voltage conversion ratio:

$$V_O=-V_I\times\frac{T_{ON}}{T_{OFF}}=-V_I\times\frac{D}{D_2}$$

Now we calculate the output current (the output voltage V_O divided by the output load R). It is the average over one switching cycle of the inductor current during the time when CR1 conducts ($D_2\times T_S$).

$$\frac{V_O}{R}=I_O=\frac{1}{T_S}\times\left[\frac{-I_{PK}}{2}\times D_2\times T_S\right]$$

Now, substitute the relationship for I_{PK} ($\Delta I_L(+)$) into the above equation to obtain:

$$\frac{V_O}{R}=I_O=\frac{1}{T_S}\times\left[\frac{1}{2}\times(-1)\times\left(\frac{V_I}{L}\times D\times T_S\right)\times D_2\times T_S\right]$$

$$\frac{V_O}{R}=\frac{-V_I\times D\times D_2\times T_S}{2\times L}$$

We now have two equations, the one for the output current (V_O divided by R) just derived and the one for the output voltage, both in terms of V_I , D , and D_2 . We now solve each equation for D_2 and set the two equations equal to each other. Using the resulting equation, an expression for the output voltage, V_O , can be derived.

The discontinuous conduction mode buck-boost voltage conversion relationship is given by:

$$V_O = -V_I \times \frac{D}{\sqrt{K}}$$

Where K is defined as

$$K = \frac{2 \times L}{R \times T_S}$$

The above relationship shows one of the major differences between the two conduction modes. For discontinuous conduction mode, the voltage conversion relationship is a function of the input voltage, duty cycle, power stage inductance, the switching frequency, and the output load resistance. For continuous conduction mode, the voltage conversion relationship is only dependent on the input voltage and duty cycle.

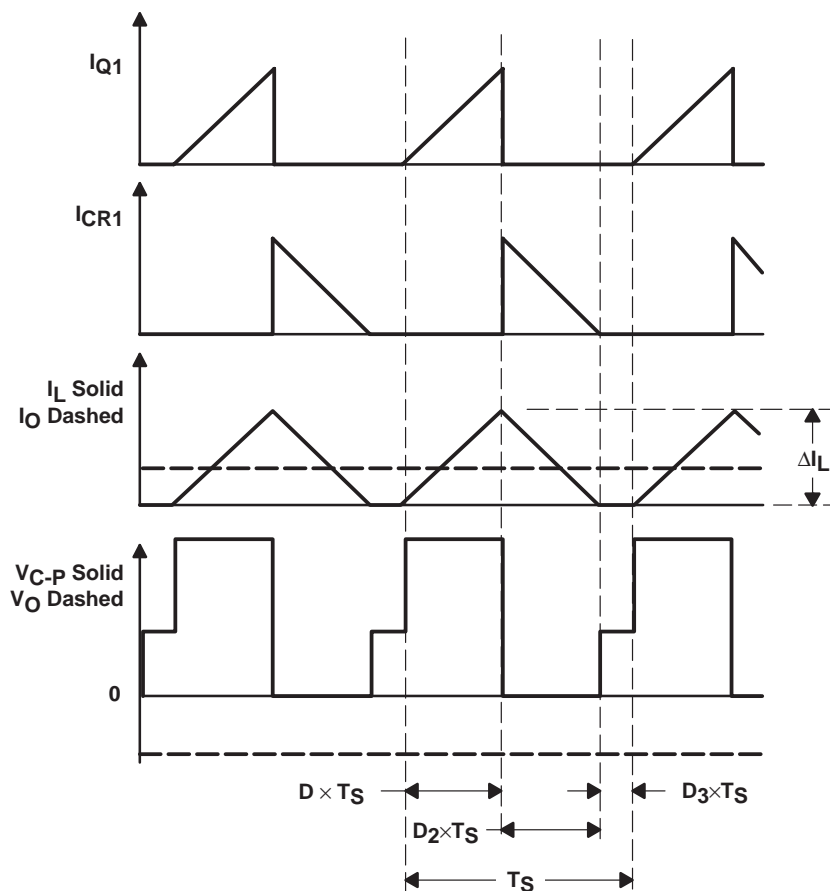

Figure 6. Discontinuous Mode Buck-Boost Converter Waveforms

In typical applications, the buck-boost power stage is operated in either continuous conduction mode or discontinuous conduction mode. For a particular application, one conduction mode is chosen and the power stage is designed to maintain the same mode. The next section gives inductance relationships for the power stage that allow it to operate in only one conduction mode, given ranges for input and output voltage and output load current.

2.3 Critical Inductance

The previous analyses for the buck-boost converter have been for continuous and discontinuous conduction modes of steady-state operation. The conduction mode of a converter is a function of input voltage, output voltage, output current, and the value of the inductor. A buck-boost converter can be designed to operate in continuous mode for load currents above a certain level, usually 5% to 10% of full load. Usually, the input voltage range, the output voltage, and load current are defined by the converter specification. This leaves the inductor value as the design parameter to maintain continuous conduction mode.

The minimum value of inductor to maintain continuous conduction mode can be determined by the following procedure.

First, define $I_{O(Crit)}$ as the minimum output current to maintain continuous conduction mode, normally referred to as the critical current. This value is shown in Figure 4. Since we are working toward a minimum value for the inductor, it is more straightforward to perform the derivation using the inductor current. The minimum average inductor current to maintain continuous conduction mode is given by:

$$I_{L(min-avg)} = \frac{\Delta I_L}{2} = I_{O(crit)}$$

Second, calculate L such that the above relationship is satisfied. To solve the above equation, either relationship, $\Delta I_L (+)$ or $\Delta I_L (-)$ may be used for ΔI_L . Note also that either relationship for ΔI_L is independent of the output current level. Here, $\Delta I_L (+)$ is used. The worst case condition (giving the largest L_{min}) is at maximum input voltage because this gives the maximum ΔI_L .

Now, substituting and solving for L_{min} :

$$L_{min} \geq \frac{1}{2} \times (V_{I(max)} - V_{DS} - I_L \times R_L) \times \frac{T_{ON(min)}}{I_{O(crit)}}$$

The above equation can be simplified by ignoring minor parasitic resistances and diode voltage drops, and rearranged for ease of use to:

$$L_{min} \geq \frac{-V_O \times T_S}{2 \times I_{O(crit)}} \times \frac{V_{I(max)}}{(V_O - V_{I(max)})}$$

Using the inductor value just calculated will guarantee continuous conduction mode operation for output load currents above the critical current level, $I_{O(crit)}$.

3 Buck-Boost Power Stage Small Signal Modeling

We now switch gears, moving from a detailed circuit oriented analysis approach to more of a system level investigation of the buck-boost power stage. This section presents techniques to assist the power supply designer in accurately modeling the power stage as a component of the control loop of a buck-boost power supply. The three major components of the power supply control loop (i.e., the power stage, the pulse width modulator, and the error amplifier) are shown in block diagram form in Figure 7.

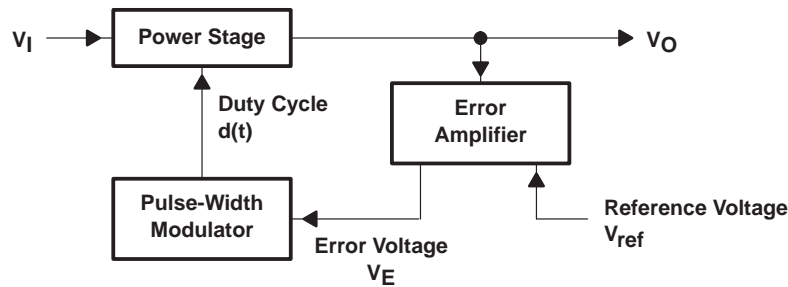

Figure 7. Power Supply Control Loop Components

Modeling the power stage presents one of the main challenges to the power supply designer. A popular technique involves modeling only the switching elements of the power stage. An equivalent circuit for these elements is derived and is called the *PWM Switch Model* where PWM is the abbreviation for the pulse width modulated. This approach is presented here.

As shown in Figure 7, the power stage has two inputs: the input voltage and the duty cycle. The duty cycle is the control input, i.e., this input is a logic signal which controls the switching action of the power stage and hence the output voltage. Most power stages have a nonlinear voltage conversion ratio versus duty cycle. To illustrate this nonlinearity, a graph of the steady-state voltage conversion ratio for a buck-boost power stage operating in continuous conduction mode as a function of steady-state duty cycle, D , is shown in Figure 8.

The nonlinear characteristics are a result of the switching action of the power stage switching components, Q1 and CR1. It was observed in reference [5] that the only nonlinear components in a power stage are the switching devices; the remainder of the circuit consists of linear elements. It was also shown in reference [5] that a linear model of only the nonlinear components could be derived by averaging the voltages and currents associated with these nonlinear components over one switching cycle. The model is then substituted into the original circuit for analysis of the complete power stage. Thus, a model of the switching devices is given and is called the *PWM switch model*.

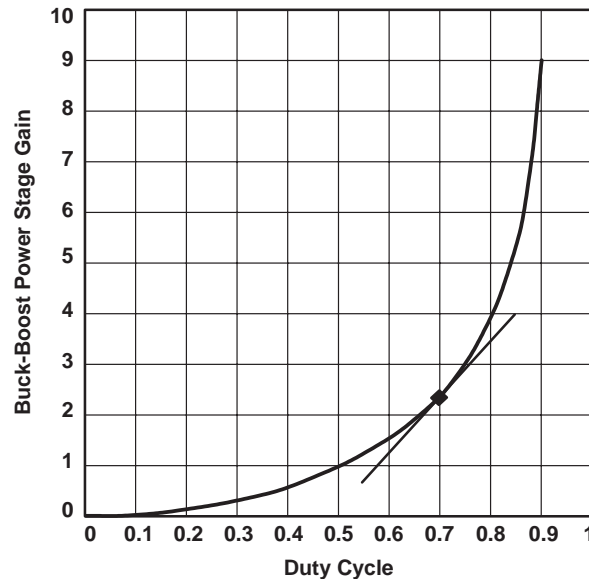

Figure 8. Buck-Boost Power Stage Gain vs Duty Cycle

The basic objective behind modeling power stages is to represent the non-linear behavior of power stages as linear about an operating point. We want linearity so that we can apply the many analysis tools available for linear systems. Referring again to Figure 8, if we choose the operating point of $D = 0.7$, a straight line can be constructed that is tangent to the original curve at the point where $D = 0.7$. This is an illustration of linearization about an operating point, a technique used to derive the PWM switch model. Qualitatively, one can see that if the variations in duty cycle are kept small, a linear model accurately represents the nonlinear behavior of the power stage being analyzed.

Since a power stage can operate in one of two conduction modes, i.e., continuous conduction mode (CCM) or discontinuous conduction mode (DCM), there is a PWM switch model for the two conduction modes. The DCM PWM switch model is derived here. The CCM PWM switch model is derived in the Application Report *Understanding Buck Power Stages in Switchmode Power Supplies*, TI Literature Number SLVA057.

3.1 Buck-Boost Continuous Conduction Mode Small-Signal Analysis

To model the buck-boost power stage operation in CCM, we use the CCM PWM switch model derived in the Application Report *Understanding Buck Power Stages in Switchmode Power Supplies*, TI Literature Number SLVA057. The PWM switch model is inserted into the power stage circuit by replacing the switching elements. The CCM PWM Switch model is shown in Figure 9. This model is useful for determining the dc operating point of a power stage and for finding ac transfer functions of a power stage.

Referring again to Figure 1, the power transistor, Q1, and the catch diode, CR1, are drawn inside a dashed-line box. These are the components that will be replaced by the PWM switch equivalent circuit. Terminal labels a (active), p (passive), and c (common) are used for the PWM switch model.

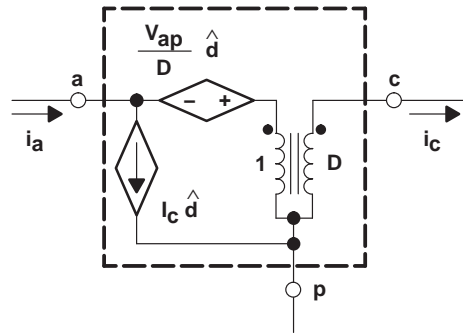

Figure 9. DC and Small Signal CCM PWM Switch Model

The a terminal is the terminal connected to the active switch. The p terminal is the terminal of the passive switch. The c terminal is the terminal that is common to both the active and passive switches. The three commonly used power stage topologies all contain active and passive switches, and the above terminal definitions can be used. In addition, substituting the PWM switch model (that we will derive) into other power stage topologies also produces a valid model for that particular power stage. To use the PWM switch model in other power stages, just substitute the model shown in Figure 9 into the power stage in the appropriate orientation.

In the PWM switch model of Figure 9 and subsequent occurrences of the model, the capital letters indicate steady-state (or dc) quantities dependent on the operating point of the circuit under study. The lowercase letters indicate time varying quantities and can indicate a quantity with a dc component and an ac component. The lowercase letters with a caret (hat) indicate the small ac variations of that particular variable. For example, D represents the steady-state duty cycle, \hat{d} represents small ac variations of the duty cycle, and d or $d(t)$ represents the complete duty cycle including any dc component and ac variations.

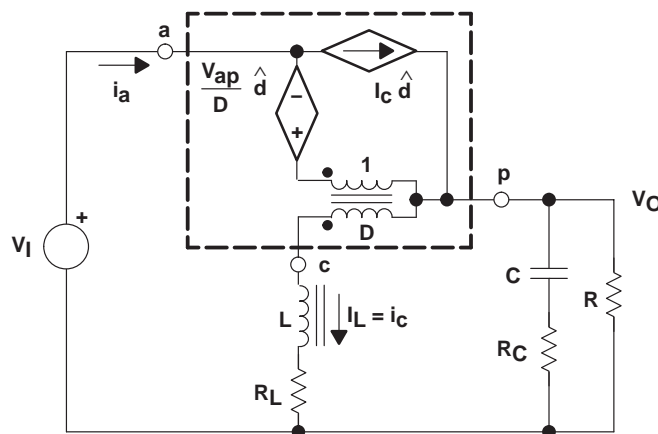

Figure 10. CCM Buck-Boost Small Signal AC Power Stage Model

An example dc analysis is given to illustrate how simple power stage analysis becomes with the PWM switch model. For dc analysis, \hat{d} is zero, L is a short and C is an open. Then by a simple loop equation we get:

$$-V_I + \frac{V_{ac}}{D} + V_O = 0$$

By using the following relationships

$$I_L = \frac{-I_O}{1-D}$$

$$I_O = \frac{V_O}{R}$$

and writing another loop to solve for V_{CP} , we get:

$$V_{cp} = -V_O \times \left(1 + \frac{R_L}{R \times (1-D)} \right)$$

Using the two loop equations, we solve them to get the steady-state voltage conversion relationship for the buck-boost power stage operating in CCM and taking the inductor dc resistance, R_L , into account:

$$V_O = -V_I \times \frac{D}{1-D} \times \frac{1}{1 + \frac{R_L}{R \times (1-D)^2}}$$

The above equation is usually expressed as a ratio of the output voltage, V_O , to the input voltage, V_I , and is usually called M as shown below:

$$M = \frac{V_O}{V_I} = -\frac{D}{1-D} \times \frac{1}{1 + \frac{R_L}{R \times (1-D)^2}}$$

Which, when $R_L = 0$, as assumed earlier, is equal to the steady-state I/O transfer function previously calculated. With the PWM switch parameters V_{ap} and I_c determined from the dc analysis, an ac analysis can be performed. For ac analysis, the following transfer functions can be calculated: open-loop line-to-output, open-loop input impedance, open-loop output impedance, and open-loop control-to-output. The control-to-output, or duty-cycle-to-output, is the transfer function most used for control loop analysis. To determine this transfer function, first use the results from the dc analysis for operating point information. This information determines the parameter values of the dependent sources; for example,

$$V_{ap} = V_I - V_O = V_I \times (1-M)$$

and

$$I_c = I_L = \frac{-I_O}{1-D} = \frac{-V_O}{R \times (1-D)} = \frac{-M \times V_I}{R \times (1-D)}$$

The above two equations are then used with loop equations to derive the duty-cycle-to-output voltage transfer function. Then set the input voltage equal to zero because we only want the ac component of the transfer function. Without going through all the details, it can be shown that the transfer function can be put in the following form:

$$\frac{\hat{v}_O}{\hat{d}}(s) = G_{do} \times \frac{\left(1 + \frac{s}{\omega_{z1}}\right) \times \left(1 - \frac{s}{\omega_{z2}}\right)}{1 + \frac{s}{\omega_o \times Q} + \frac{s^2}{\omega_o^2}}$$

Where:

$$G_{do} \approx \frac{V_I}{(1 - D)^2}$$

$$s_{z1} = \frac{1}{R_C \times C}$$

$$s_{z2} \approx \frac{(1 - D)^2 \times R}{D \times L}$$

$$\omega_o \approx \frac{1 - D}{\sqrt{L \times C}}$$

$$Q \approx \frac{(1 - D) \times R}{\sqrt{\frac{L}{C}}}$$

3.2 Buck-Boost Discontinuous Conduction Mode Small-Signal Analysis

We now continue our discussion of modeling the power stage when it is operating in discontinuous conduction mode (DCM). This mode is quite different from continuous conduction mode just covered. We begin with the derivation of the PWM switch model for DCM for the buck-boost power stage. This derivation can also be found in [4]. The waveforms that are averaged are the voltage across Q1, v_{ac} , the voltage across CR1, v_{cp} , the current in Q1, i_a and the current in CR1, i_p . The waveforms are shown in Figure 6.

We first state some basic relationships that are used repeatedly. The terminal currents averaged over one switching cycle are given by:

$$\langle i_a \rangle = \frac{i_{pk}}{2} \times d$$

$$\langle i_p \rangle = \frac{i_{pk}}{2} \times d_2$$

where variables in brackets (e.g., $\langle i_a \rangle$) represent quantities that are averaged over one switching cycle.

Since the average over one switching cycle of the voltage across the inductor is zero, the following average voltage relationships hold:

$$\begin{aligned}\langle v_{ac} \rangle &= V_I + (i_c \times R_L) \\ \langle v_{cp} \rangle &= -V_O - (i_c \times R_L)\end{aligned}$$

Since the value of $i_c R_L$ is small compared to V_I and V_O , ignore these values for modeling the power stage to make the formulae much easier to manipulate. During the time period $d \times T_s$ the current i_a starts at a value of zero and ends at the value of i_{pk} . And since the voltage across the inductor during this time is constant and equal to $V_I = \langle v_{ac} \rangle$, the following holds:

$$V_I = L \frac{\Delta i_a}{\Delta t} = L \times \frac{i_{pk}}{d \times T_s} \Rightarrow \langle v_{ac} \rangle = L \times \frac{i_{pk}}{d \times T_s}$$

Similarly, during the time period $d2 T_s$, the current i_p starts at a value of i_{pk} and ends at zero. Also since the voltage across the inductor is equal to $-V_O = \langle v_{cp} \rangle$, the following holds:

$$V_O = L \frac{\Delta i_p}{\Delta t} = L \times \frac{-i_{pk}}{d2 \times T_s} \Rightarrow \langle v_{cp} \rangle = L \times \frac{i_{pk}}{d2 \times T_s}$$

With the above four equations, we begin with the derivation of the input side (v_{ac} side) of the PWM switch model.

We solve equation (3) for i_{pk} and use $V_I = \langle v_{ac} \rangle$, then substitute into equation (1) to get:

$$\langle i_a \rangle = V_I \times \frac{d^2 \times T_s}{2 \times L}$$

We note that the average current flowing into terminal a is proportional to the input voltage, V_I . We define an effective resistance as follows:

$$R_e = \frac{V_I}{\langle i_a \rangle} = \frac{2 \times L}{d^2 \times T_s}$$

Once the input looks like an equivalent resistance, we can also talk about an apparent input power of V_I^2 / R_e which will be used next.

To begin the derivation of the output side (v_{cp} side), we start with equation (4), solve equation (3) for i_{pk} and substitute back into equation (4), we get:

$$\langle v_{cp} \rangle = \frac{\langle v_{ac} \rangle \times d}{d_2}$$

We next solve the above equation for d_2 and substitute into equation (2) and also use i_{pk} [from equation (3)] and substitute into equation (2), we get after rearranging:

$$\langle i_p \rangle = \frac{\langle v_{ac} \rangle^2 \times d^2 \times T_s}{\langle v_{cp} \rangle \times 2 \times L}$$

Finally, we use $\langle v_{ac} \rangle = V_I$ and substitute in the above equation to get the output side relationship:

$$\langle i_p \rangle \times \langle v_{cp} \rangle = V_I^2 \times \frac{d^2 \times T_s}{2 \times L} = \frac{V_I^2}{R_e}$$

This equation shows that the average output current times the average output voltage is equal to the apparent input power.

Now we can implement the above input and output relationships into an equivalent circuit model. This model is useful for determining the dc operating point of a power supply. The input port is simply modeled with a resistor, R_e . The output port is modeled as a dependent power source. This power source delivers power equal to that dissipated by the input resistor, R_e . The equivalent circuit can be constructed as shown in Figure 11.

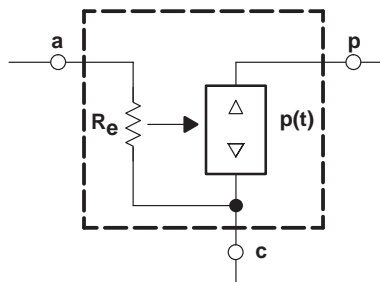

Figure 11. DCM PWM Switch Model

To illustrate discontinuous conduction mode power supply steady-state analysis using this model, we examine the buck-boost converter. The analysis proceeds like the CCM case. The equivalent circuit is substituted into the original circuit. The inductor is treated as a short circuit and the capacitor is treated as an open circuit. The DCM buck-boost converter model schematic is shown in the Figure 12.

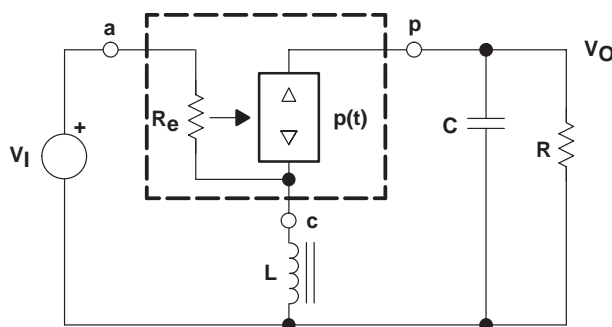

Figure 12. DCM Buck-Boost Converter Model

The apparent power *dissipated* in R_e is determined as:

$$P_{Re} = \frac{V_I^2}{R_e} \cdot$$

The dependent power source delivers the above amount of power to the output load resistor, R . We can calculate the voltage gain as a function of D by equating the two powers as shown:

$$\begin{aligned} \frac{V_I^2}{R_e} &= \frac{V_O^2}{R} \\ \frac{V_O}{V_I} &= \pm \sqrt{\frac{R}{R_e}} \text{ (choose the negative root)} \\ \sqrt{\frac{R}{R_e}} &= \sqrt{\frac{R}{\frac{2 \times L}{D^2 \times T_s}}} = D \sqrt{\frac{R \times T_s}{2 \times L}} \end{aligned}$$

The voltage conversion relationship for the DCM buck-boost is given by:

$$\frac{V_O}{V_I} = -D \sqrt{\frac{R \times T_s}{2 \times L}}$$

Recall from earlier that:

$$K = \frac{2 \times L}{R \times T_s}$$

and making the substitution in the above equation, the result is identical to that obtained by balancing the inductor volt-seconds in the buck-boost steady-state discontinuous conduction mode analysis section.

The steady state voltage conversion relationship for the DCM buck-boost becomes:

$$\frac{V_O}{V_I} = -\frac{D}{\sqrt{K}}$$

Now, to derive the small signal model, the circuit of Figure 12 is perturbed and linearized following the procedure similar to the one in the CCM derivation. To see the detail of the derivation, the reader is directed to reference [4] for details. The resulting small signal model for the buck-boost power stage operating in DCM is shown in the Figure 13.

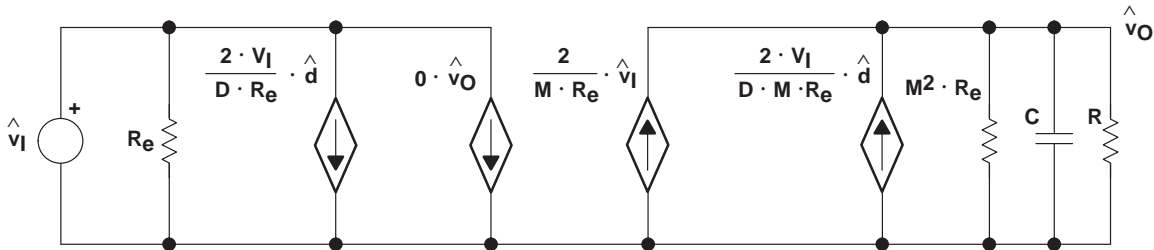

Figure 13. Small Signal DCM Buck-Boost Power Stage Model

The duty-cycle-to-output transfer function for the buck-boost power stage operating in DCM is given by

$$\frac{\hat{v}_O}{\hat{d}} = G_{do} \times \frac{1}{1 + \frac{s}{\omega_p}}$$

Where

$$G_{do} = \frac{V_O}{D}$$

$$D = -M \times \sqrt{K}$$

$$M = \frac{V_O}{V_I}$$

$$K = \frac{2 \times L}{R \times T_s}$$

and

$$\omega_p = \frac{2}{R \times C}$$

The expression for G_{do} can be simplified to the following:

$$G_{do} = -V_I \times \sqrt{\frac{R \times T_s}{2 \times L}}$$

4 Variations of the Buck-Boost Power Stage

4.1 Flyback Power Stage

A transformer-coupled variation of the traditional buck-boost power stage is the flyback power stage. This power stage operates like the traditional buck-boost power stage except that the single winding inductor is replaced with a two (or more) winding coupled inductor. The power switch, Q1 in Figure 14, applies the input voltage to the primary side (L_{PRI}) of the coupled inductor. Energy is stored until Q1 is turned off. Energy is then delivered to the output capacitor and load resistor combination from the secondary side (L_{SEC}) of the coupled inductor through the output diode CR1. This power stage provides electrical isolation of the input voltage from the output voltage. Besides providing electrical isolation, the isolation transformer can step-down (or step-up) the input voltage to the secondary. The transformer turns ratio can be designed so that reasonable duty cycles are obtained for almost any input voltage/output voltage combination, thus avoiding extremely small or extremely high duty cycle values.

The flyback power stage also eliminates two characteristics which sometimes make the standard buck-boost power stage unattractive; i.e., the output voltage is opposite in polarity from the input voltage and the power switch requires a floating drive. Besides providing isolation, the coupled inductor secondary can be connected to produce an output voltage of either positive or negative polarity. In addition, since the power switch is in series with the primary of the coupled inductor, the power switch can be connected so that the source is ground referenced instead of connecting the drain to the input voltage as in the standard buck-boost power stage.

The flyback power stage is very popular in 48-V input telecom applications and 110-V ac or 220-V ac off-line applications for output power levels up to approximately 50 watts. The exact power rating of the flyback power stage, of course, is dependent on the input voltage/output voltage combination, its operating environment and many other factors. Additional output voltages can be generated easily by simply adding another winding to the coupled inductor along with an output diode and output capacitor. Obtaining multiple output voltages from a single power stage is another advantage of the flyback power stage.

A simplified schematic of the flyback power stage with a drive circuit block included is shown in Figure 14. In the schematic shown, the secondary winding of the coupled inductor is connected to produce a positive output voltage. The power switch, Q1, is an n-channel MOSFET. The diode, CR1, is usually called the output diode. The secondary inductance, L_{SEC} , and capacitor, C, make up the output filter. The capacitor ESR, R_C , (equivalent series resistance) is not included. The resistor, R, represents the load seen by the power supply output.

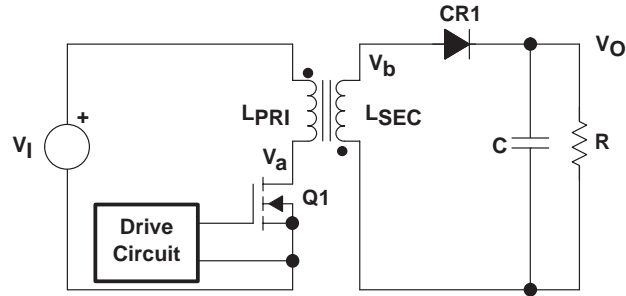

Figure 14. Flyback Power Stage Schematic

The important waveforms for the flyback power stage operating in DCM are shown in Figure 15.

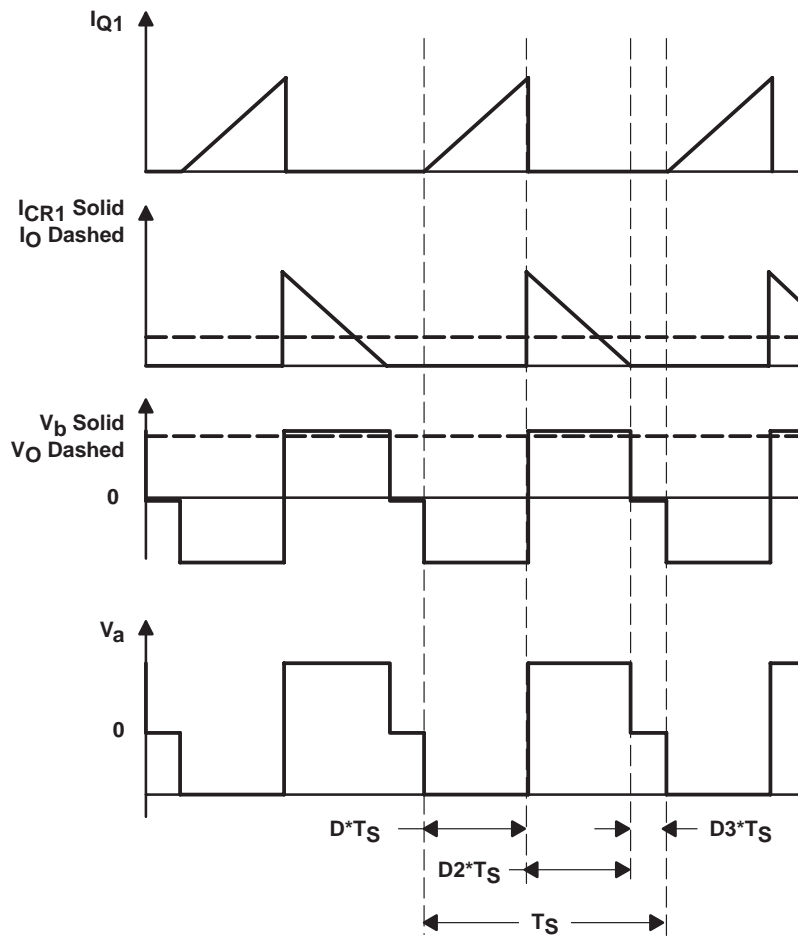

Figure 15. Discontinuous Mode Flyback Waveforms

The simplified voltage conversion relationship for the flyback power stage operating in CCM (ignoring parasitics) is given by:

$$V_O = V_I \times \frac{N_s}{N_p} \times \frac{D}{1 - D}$$

The simplified voltage conversion relationship for the flyback power stage operating in DCM (ignoring parasitics) is given by:

$$V_O = V_I \times \frac{N_s}{N_p} \times \frac{D}{\sqrt{K}}$$

Where K is defined as:

$$K = \frac{2 \times L_{SEC}}{R \times T_s}$$

The simplified duty-cycle-to-output transfer function for the flyback power stage operating in CCM is given by:

$$\frac{\hat{v}_O}{\hat{d}}(s) = G_{do} \times \frac{N_S}{N_P} \times \frac{\left(1 + \frac{s}{\omega_{z1}}\right) \times \left(1 - \frac{s}{\omega_{z2}}\right)}{1 + \frac{s}{\omega_o \times Q} + \frac{s^2}{\omega_o^2}}$$

Where:

$$G_{do} \approx \frac{V_I}{(1 - D)^2}$$

$$\omega_{z1} = \frac{1}{R_C \times C}$$

$$\omega_{z2} \approx \frac{(1 - D)^2 \times R}{D \times L_{SEC}}$$

$$\omega_o \approx \frac{1 - D}{\sqrt{L_{SEC} \times C}}$$

$$Q \approx \frac{(1 - D) \times R}{\sqrt{\frac{L_{SEC}}{C}}}$$

The simplified duty-cycle-to-output transfer function for the flyback power stage operating in DCM is given by:

$$\frac{\hat{V}_O}{\hat{d}} = G_{do} \times \frac{1}{1 + \frac{s}{\omega_p}}$$

Where:

$$G_{do} = V_I \times \frac{N_S}{N_P} \times \sqrt{\frac{R \times T_S}{2 \times L_{SEC}}}$$

and

$$\omega_p = \frac{2}{R \times C}$$

5 Component Selection

This section presents a discussion of the function of each of the main components of the buck-boost power stage. The electrical requirements and applied stresses are given for each power stage component.

The completed power supply, made up of a power stage and a control circuit, usually must meet a set of minimum performance requirements. This set of requirements is usually referred to as the power supply specification. Many times, the power supply specification determines individual component requirements.

5.1 Output Capacitance

In switching power supply power stages, the output capacitance stores energy in the electric field due to the voltage applied. Thus, qualitatively, the function of a capacitor is to attempt to maintain a constant voltage.

The value of output capacitance of a buck-boost power stage is generally selected to limit output voltage ripple to the level required by the specification. The series impedance of the capacitor and the power stage output current determine the output voltage ripple. The three elements of the capacitor that contribute to its impedance (and output voltage ripple) are equivalent series resistance (ESR), equivalent series inductance (ESL), and capacitance (C). The following gives guidelines for output capacitor selection.

For continuous inductor current mode operation, to determine the amount of capacitance needed as a function of output load current, I_O , switching frequency, f_S , and desired output voltage ripple, ΔV_O , the following equation is used assuming all the output voltage ripple is due to the capacitor's capacitance. This is because the output capacitor supplies the entire output load current during the power stage ON state.

$$C \geq \frac{I_{O(Max)} \times D_{Max}}{f_S \times \Delta V_O}$$

Where $I_{O(Max)}$ is the maximum output current and D_{Max} is the maximum duty cycle.

For discontinuous inductor current mode operation, to determine the amount of capacitance needed, the following equation is used, assuming all the output voltage ripple is due to the capacitor's capacitance.

$$C \geq \frac{I_{O(Max)} \times \left(1 - \sqrt{\frac{2 \times L}{R \times T_s}}\right)}{f_s \times \Delta V_O}$$

However, in many practical designs, to get the required ESR, a capacitor with much more capacitance than is needed must be selected.

For continuous inductor current mode operation and assuming there is enough capacitance such that the ripple due to the capacitance can be ignored, the ESR needed to limit the ripple to ΔV_O V peak-to-peak is:

$$ESR \leq \frac{\Delta V_O}{\left(\frac{I_{O(Max)}}{1 - D_{Max}} + \frac{\Delta I_L}{2}\right)}$$

For discontinuous inductor current mode operation and assuming there is enough capacitance such that the ripple due to the capacitance can be ignored, the ESR needed to limit the ripple to ΔV_O V peak-to-peak is simply:

$$ESR \leq \frac{\Delta V_O}{\Delta I_L}$$

Ripple current flowing through a capacitor's ESR causes power dissipation in the capacitor. This power dissipation causes a temperature increase internal to the capacitor. Excessive temperature can seriously shorten the expected life of a capacitor. Capacitors have ripple current ratings that are dependent on ambient temperature and should not be exceeded. Referring to Figure 3, the output capacitor ripple current is the inductor current, I_L , minus the output current, I_O . The RMS value of the ripple current flowing in the output capacitance (continuous inductor current mode operation) is given by:

$$I_{C\ RMS} = I_O \times \sqrt{\frac{D}{1 - D}}$$

ESL can be a problem by causing ringing in the low megahertz region but can be controlled by choosing low ESL capacitors, limiting lead length (PCB and capacitor), and replacing one large device with several smaller ones connected in parallel.

Three capacitor technologies: low-impedance aluminum, organic semiconductor, and solid tantalum are suitable for low-cost commercial applications. Low-impedance aluminum electrolytics are the lowest cost and offer high capacitance in small packages, but ESR is higher than the other two. Organic semiconductor electrolytics, such as the Sanyo OS-CON series, have become very popular for the power-supply industry in recent years. These capacitors offer the best of both worlds – a low ESR that is stable over the temperature range and high capacitance in a small package. Most of the OS-CON units are supplied in lead-mounted radial packages; surface-mount devices are available but much of the size and performance advantage is sacrificed. Solid-tantalum chip capacitors are probably the best choice if a surface-mounted device is an absolute must. Products such as the AVX TPS family and the Sprague 593D family were developed for power-supply applications. These products offer a low ESR that is relatively stable over the temperature range, high ripple-current capability, low ESL, surge-current testing, and a high ratio of capacitance to volume.

5.2 Output Inductance

In switching power supply power stages, the function of inductors is to store energy. The energy is stored in their magnetic field due to the current flowing. Thus, qualitatively, the function of an inductor is usually to attempt to maintain a constant current or equivalently to limit the rate of change of current flow.

The value of output inductance of a buck-boost power stage is generally selected to limit the peak-to-peak ripple current flowing in it. In doing so, the power stage's mode of operation, continuous or discontinuous, is determined. The inductor ripple current is directly proportional to the applied voltage and the time that the voltage is applied, and it is inversely proportional to its inductance. This was explained in detail previously.

Many designers prefer to design the inductor themselves, but that topic is beyond the scope of this report. However, the following discusses the considerations necessary for selecting the appropriate inductor.

In addition to the inductance, other important factors to be considered when selecting the inductor are its maximum dc or peak current and maximum operating frequency. Using the inductor within its dc current rating is important to insure that it does not overheat or saturate. Operating the inductor at less than its maximum frequency rating insures that the maximum core loss is not exceeded, resulting in overheating or saturation.

Magnetic component manufacturers offer a wide range of off-the-shelf inductors suitable for dc/dc converters, some of which are surface mountable. There are many types of inductors available; the most popular core materials are ferrites and powdered iron. Bobbin or rod-core inductors are readily available and inexpensive, but care must be exercised in using them, because they are more likely to cause noise problems than are other shapes. Custom designs are also feasible, provided the volumes are sufficiently high.

Current flowing through an inductor causes power dissipation due to the inductor's dc resistance; this power dissipation is easily calculated. Power is also dissipated in the inductor's core due to the flux swing caused by the ac voltage applied across it but this information is rarely directly given in manufacturer's data sheets. Occasionally, the inductor's maximum operating frequency and/or applied volt-seconds ratings give the designer some guidance regarding core loss. The power dissipation causes a temperature increase in the inductor. Excessive temperature can cause degradation in the insulation of the winding and cause increased core loss. Care should be exercised to insure all the inductor's maximum ratings are not exceeded.

The loss in the inductor is given by:

$$P_{inductor} = (I_{Lrms})^2 \times R_{Cu} + P_{Core}$$

where, R_{Cu} is the winding resistance.

5.3 Power Switch

In switching power supply power stages, the function of the power switch is to control the flow of energy from the input power source to the output voltage. In a buck-boost power stage, the power switch (Q1 in Figure 1) connects the input to the inductor when the switch is turned on and disconnects when the switch is off. The power switch must conduct the current in the output inductor while on and block the difference between the input voltage and output voltage when off. Also, the power switch must change from one state to the other quickly in order to avoid excessive power dissipation during the switching transition.

The type of power switch considered in this report is a power MOSFET. Other power devices are available but in most instances, the MOSFET is the best choice in terms of cost and performance (when the drive circuits are considered). The two types of MOSFET available for use are the n-channel and the p-channel. P-channel MOSFETs are popular for use in buck-boost power stages because driving the gate is simpler than the gate drive required for an n-channel MOSFET.

The power dissipated by the power switch, Q1, is given by:

$$P_{D(Q1)} = (I_{Lrms})^2 \times R_{DS(on)} \times D + \frac{1}{2} \times (V_I - V_O) \times \left(\frac{I_O}{1 - D} \right) \times (t_r + t_f) \times f_S + Q_{Gate} \times V_{GS} \times f_S$$

Where:

t_r and t_f are the MOSFET turn-on and turn-off switching times
 Q_{Gate} is the MOSFET total gate charge

Other than selecting p-channel or n-channel, other parameters to consider while selecting the appropriate MOSFET are the maximum drain-to-source breakdown voltage, $V_{(BR)DSS}$ and the maximum drain current: $I_{D(Max)}$.

The MOSFET selected should have a $V_{(BR)DSS}$ rating greater than the maximum difference between the input voltage and output voltage, and some margin should be added for transients and spikes. The MOSFET selected should also have an $I_{D(Max)}$ rating of at least two times the maximum power stage inductor current. However, many times this is not sufficient margin and the MOSFET junction temperature should be calculated to make sure that it is not exceeded. The junction temperature can be estimated as follows:

$$T_J = T_A + P_D \times R_{\theta JA}$$

Where:

T_A is the ambient or heatsink temperature

$R_{\theta JA}$ is the thermal resistance from the MOSFET chip to the ambient air or heatsink.

5.4 Output Diode

The output diode conducts when the power switch turns off and provides a path for the inductor current. Important criteria for selecting the rectifier include: fast switching, breakdown voltage, current rating, low-forward voltage drop to minimize power dissipation, and appropriate packaging. Unless the application justifies the expense and complexity of a synchronous rectifier, the best solution for low-voltage outputs is usually a Schottky rectifier. The breakdown voltage must be greater than the maximum difference between the input voltage and output voltage, and some margin should be added for transients and spikes. The current rating should be at least two times the maximum power stage output current. Normally the current rating will be much higher than the output current because power and junction temperature limitations dominate the device selection.

The voltage drop across the diode in a conducting state is primarily responsible for the losses in the diode. The power dissipated by the diode can be calculated as the product of the forward voltage and the output load current. The switching losses which occur at the transitions from conducting to non-conducting states are very small compared to conduction losses and are usually ignored.

The power dissipated by the catch rectifier is given by:

$$P_{D(Diode)} = V_D \times I_O \times (1 - D)$$

where V_D is the forward voltage drop of the catch rectifier.

The junction temperature can be estimated as follows:

$$T_J = T_A + P_D \times R_{\theta JA}$$

6 Summary

This application report described and analyzed the operation of the buck-boost power stage. The two modes of operation, continuous conduction mode and discontinuous conduction mode, were examined. Steady-state and small-signal were the two analyses performed on the buck-boost power stage. The flyback power stage was presented as a variation of the basic buck-boost power stage.

The main results of the steady-state analyses are summarized below.

The voltage conversion relationship for CCM is:

$$V_O = - \left[(V_I - V_{DS}) \times \frac{D}{1-D} - V_d - \frac{I_L \times R_L}{1-D} \right]$$

or a slightly simpler version:

$$V_O = - V_I \times \frac{D}{1-D} \times \frac{1}{1 + \frac{R_L}{R \times (1-D)^2}}$$

which can be simplified to:

$$V_O = - V_I \times \frac{D}{1-D}$$

The relationship between the average inductor current and the output current for the continuous mode buck-boost power stage is given by:

$$I_{L(Avg)} = \frac{-I_O}{(1-D)}$$

The discontinuous conduction mode buck-boost voltage conversion relationship is given by:

$$V_O = - V_I \times \frac{D}{\sqrt{K}}$$

where K is defined as:

$$K = \frac{2 \times L}{R \times T_s}$$

The major results of the small-signal analyses are summarized below.

The small-signal duty-cycle-to-output transfer function for the buck-boost power stage operating in CCM is given by:

$$\frac{\hat{v}_O}{\hat{d}}(s) = G_{do} \times \frac{\left(1 + \frac{s}{\omega_{z1}}\right) \times \left(1 - \frac{s}{\omega_{z2}}\right)}{1 + \frac{s}{\omega_o \times Q} + \frac{s^2}{\omega_o^2}}$$

Where:

$$G_{do} \approx \frac{V_I}{(1 - D)^2}$$

$$s_{z1} = \frac{1}{R_C \times C}$$

$$s_{z2} \approx \frac{(1 - D)^2 \times R}{D \times L}$$

$$\omega_o \approx \frac{1 - D}{\sqrt{L \times C}}$$

$$Q \approx \frac{(1 - D) \times R}{\sqrt{\frac{L}{C}}}$$

The small-signal duty-cycle-to-output transfer function for the buck-boost power stage operating in DCM is given by:

$$\frac{\hat{v}_O}{\hat{d}} = G_{do} \times \frac{1}{1 + \frac{s}{\omega_p}}$$

Where:

$$G_{do} = \frac{V_O}{D} = -\frac{V_I}{\sqrt{K}}$$

and

$$\omega_p = \frac{2}{R \times C}$$

Also presented were requirements for the buck-boost power stage components based on voltage and current stresses applied during the operation of the buck-boost power stage.

For further study, several references are given.

7 References

1. Application Report *Designing With The TL5001 PWM Controller*, TI Literature Number SLVA034A.
2. Application Report *Designing Fast Response Synchronous Buck Regulators Using the TPS5210*, TI Literature Number SLVA044
3. V. Vorperian, R. Tymerski, and F. C. Lee, *Equivalent Circuit Models for Resonant and PWM Switches*, *IEEE Transactions on Power Electronics*, Vol. 4, No. 2, pp. 205-214, April 1989.
4. R. W. Erickson, *Fundamentals of Power Electronics*, New York: Chapman and Hall, 1997.
5. V. Vorperian, *Simplified Analysis of PWM Converters Using the Model of the PWM Switch: Parts I and II*, *IEEE Transactions on Aerospace and Electronic Systems*, Vol. AES-26, pp. 490-505, May 1990.
6. E. van Dijk, *et al.*, *PWM-Switch Modeling of DC-DC Converters*, *IEEE Transactions on Power Electronics*, Vol. 10, No. 6, pp. 659-665, November 1995.
7. G. W. Wester and R. D. Middlebrook, *Low-Frequency Characterization of Switched Dc-Dc Converters*, *IEEE Transactions on Aerospace and Electronic Systems*, Vol. AES-9, pp. 376-385, May 1973.
8. R. D. Middlebrook and S. Cuk, *A General Unified Approach to Modeling Switching-Converter Power Stages*, *International Journal of Electronics*, Vol. 42, No. 6, pp. 521-550, June 1977.
9. E. Rogers, *Control Loop Modeling of Switching Power Supplies*, Proceedings of EETimes Analog & Mixed-Signal Applications Conference, July 13-14, 1998, San Jose, CA.

IMPORTANT NOTICE

Texas Instruments Incorporated and its subsidiaries (TI) reserve the right to make corrections, modifications, enhancements, improvements, and other changes to its products and services at any time and to discontinue any product or service without notice. Customers should obtain the latest relevant information before placing orders and should verify that such information is current and complete. All products are sold subject to TI's terms and conditions of sale supplied at the time of order acknowledgment.

TI warrants performance of its hardware products to the specifications applicable at the time of sale in accordance with TI's standard warranty. Testing and other quality control techniques are used to the extent TI deems necessary to support this warranty. Except where mandated by government requirements, testing of all parameters of each product is not necessarily performed.

TI assumes no liability for applications assistance or customer product design. Customers are responsible for their products and applications using TI components. To minimize the risks associated with customer products and applications, customers should provide adequate design and operating safeguards.

TI does not warrant or represent that any license, either express or implied, is granted under any TI patent right, copyright, mask work right, or other TI intellectual property right relating to any combination, machine, or process in which TI products or services are used. Information published by TI regarding third-party products or services does not constitute a license from TI to use such products or services or a warranty or endorsement thereof. Use of such information may require a license from a third party under the patents or other intellectual property of the third party, or a license from TI under the patents or other intellectual property of TI.

Reproduction of TI information in TI data books or data sheets is permissible only if reproduction is without alteration and is accompanied by all associated warranties, conditions, limitations, and notices. Reproduction of this information with alteration is an unfair and deceptive business practice. TI is not responsible or liable for such altered documentation. Information of third parties may be subject to additional restrictions.

Resale of TI products or services with statements different from or beyond the parameters stated by TI for that product or service voids all express and any implied warranties for the associated TI product or service and is an unfair and deceptive business practice. TI is not responsible or liable for any such statements.

TI products are not authorized for use in safety-critical applications (such as life support) where a failure of the TI product would reasonably be expected to cause severe personal injury or death, unless officers of the parties have executed an agreement specifically governing such use. Buyers represent that they have all necessary expertise in the safety and regulatory ramifications of their applications, and acknowledge and agree that they are solely responsible for all legal, regulatory and safety-related requirements concerning their products and any use of TI products in such safety-critical applications, notwithstanding any applications-related information or support that may be provided by TI. Further, Buyers must fully indemnify TI and its representatives against any damages arising out of the use of TI products in such safety-critical applications.

TI products are neither designed nor intended for use in military/aerospace applications or environments unless the TI products are specifically designated by TI as military-grade or "enhanced plastic." Only products designated by TI as military-grade meet military specifications. Buyers acknowledge and agree that any such use of TI products which TI has not designated as military-grade is solely at the Buyer's risk, and that they are solely responsible for compliance with all legal and regulatory requirements in connection with such use.

TI products are neither designed nor intended for use in automotive applications or environments unless the specific TI products are designated by TI as compliant with ISO/TS 16949 requirements. Buyers acknowledge and agree that, if they use any non-designated products in automotive applications, TI will not be responsible for any failure to meet such requirements.

Following are URLs where you can obtain information on other Texas Instruments products and application solutions:

Products		Applications	
Amplifiers	amplifier.ti.com	Audio	www.ti.com/audio
Data Converters	dataconverter.ti.com	Automotive	www.ti.com/automotive
DSP	dsp.ti.com	Broadband	www.ti.com/broadband
Interface	interface.ti.com	Digital Control	www.ti.com/digitalcontrol
Logic	logic.ti.com	Military	www.ti.com/military
Power Mgmt	power.ti.com	Optical Networking	www.ti.com/opticalnetwork
Microcontrollers	microcontroller.ti.com	Security	www.ti.com/security
RFID	www.ti-rfid.com	Telephony	www.ti.com/telephony
Low Power Wireless	www.ti.com/lpw	Video & Imaging	www.ti.com/video
		Wireless	www.ti.com/wireless

Mailing Address: Texas Instruments, Post Office Box 655303, Dallas, Texas 75265
Copyright © 2007, Texas Instruments Incorporated