

A.2 BOARD LAYOUT AND SCHEMATICS

FIGURE A-1: EXPLORER 8 DEVELOPMENT BOARD

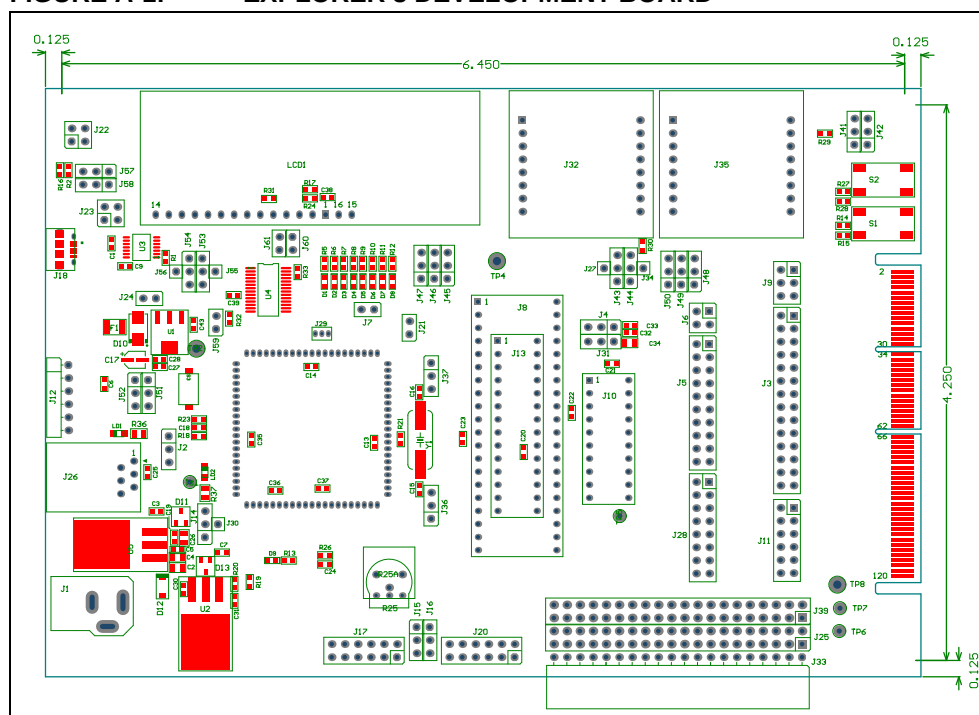

FIGURE A-2: EXPLORER 8 DEVELOPMENT SCHEMATIC - 1

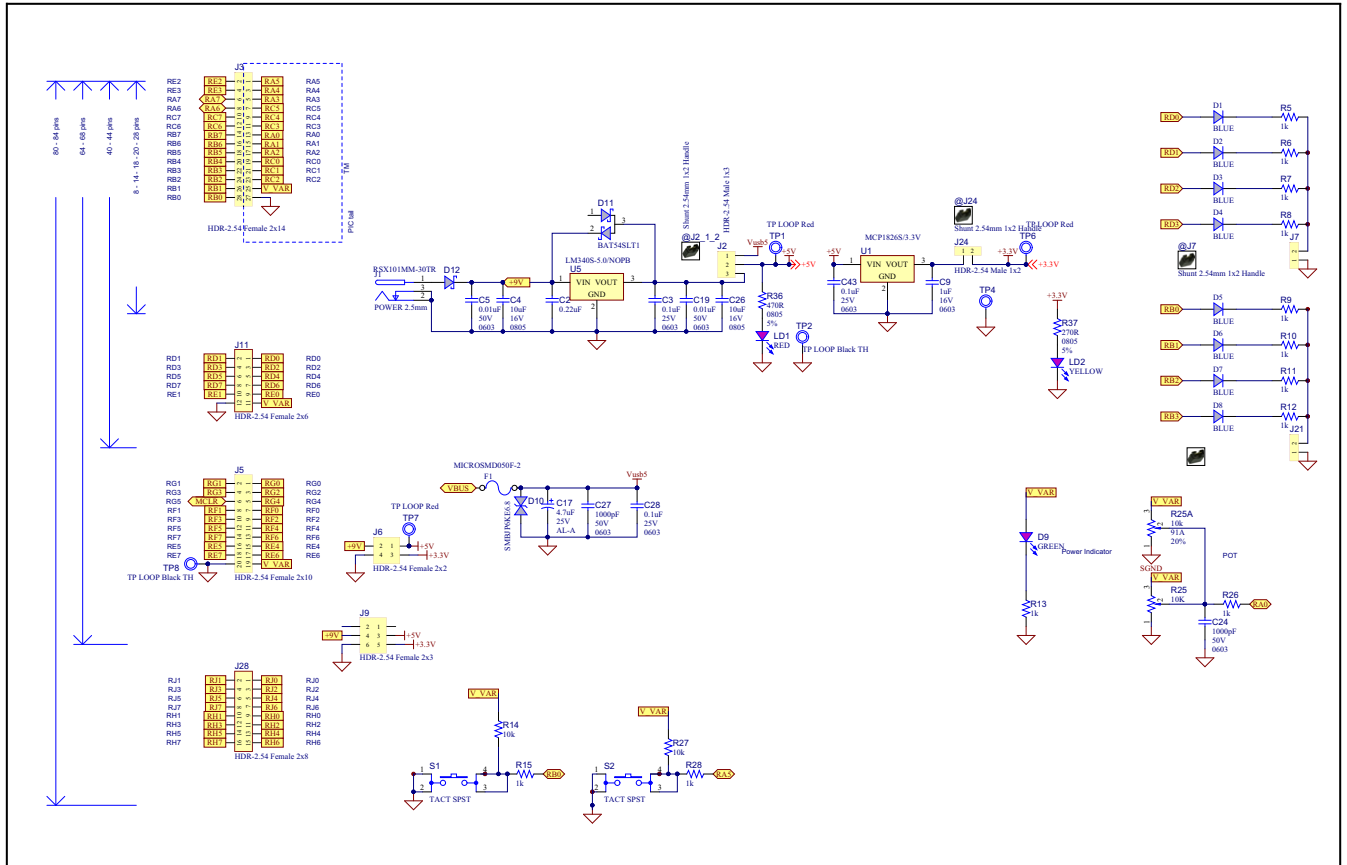

FIGURE A-3: EXPLORER 8 DEVELOPMENT SCHEMATIC - 2

