



## Product Name List

Model	Package	Overcharge detection voltage [VOCU] (V)	Overcharge release voltage [VOCR] (V)	Overdischarge detection voltage [VODL] (V)	Overdischarge release voltage [VODR] (V)	Overcurrent detection voltage [VOI1] (mV)
	SOT-23-6					
FS312	AR	4.250±0.025	4.050±0.05	2.4±0.08	3.0±0.08	200±30
	BR	4.350±0.025	4.150±0.05	2.4±0.08	3.0±0.08	200±30
	CR	4.250±0.025	4.050±0.05	2.4±0.08	3.0±0.08	150±30
	DR	4.350±0.025	4.150±0.05	2.4±0.08	3.0±0.08	150±30
	ER	4.280±0.025	3.980±0.05	2.3±0.08	3.1±0.08	125±30
	FR	4.250±0.025	4.050±0.05	2.9±0.08	3.0±0.08	150±30

Overcharge and overdischarge and overcurrent detection voltages can be changed at the customer's request.

## Pin Configuration

Pin No.	Symbol	Description
1	OD	FET gate connection pin for discharge control
2	CSI	Input pin for current sense, charger detect
3	OC	FET gate connection pin for charge control
4	NC	No connection
5	VDD	Positive power input pin
6	VSS	Negative power input pin

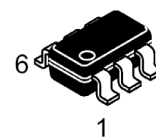
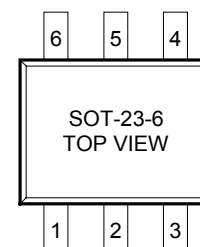

## Functional Block Diagram

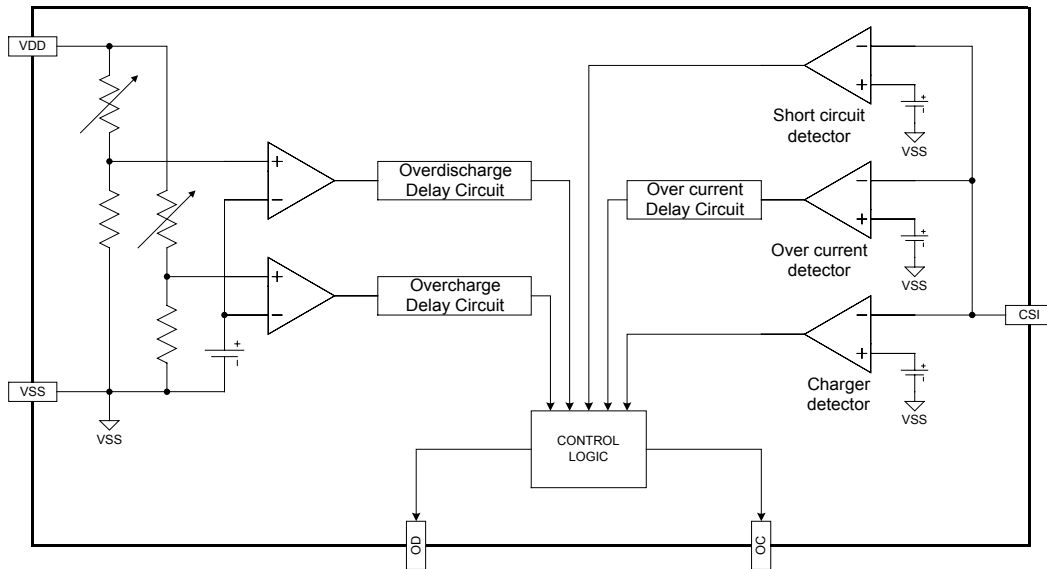

## Typical Application Circuit

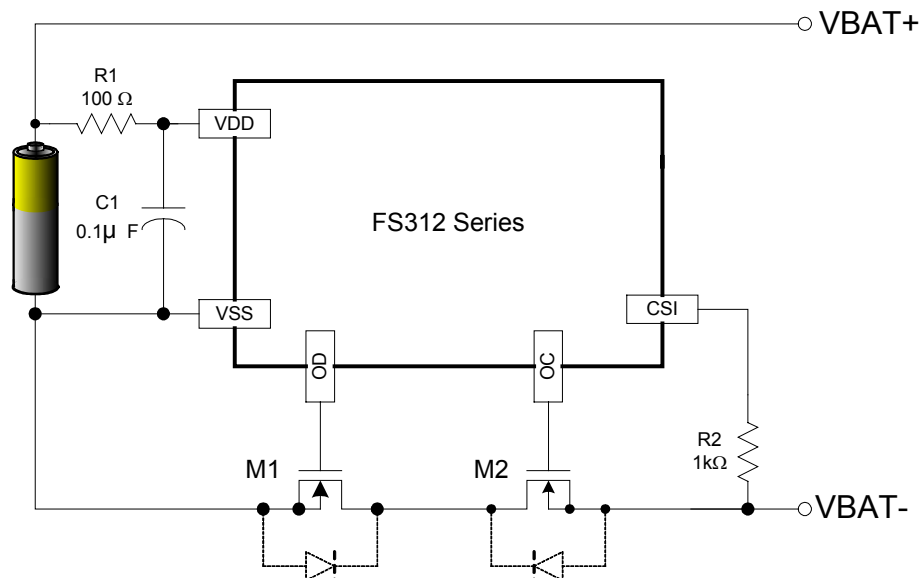

## Absolute Maximum Ratings

(VSS=0V, Ta=25°C unless otherwise specified)

Item	Symbol	Rating	Unit
Input voltage between VDD and VSS *	VDD	VSS-0.3 to VSS+12	V
OC output pin voltage	VOC	VDD-26 to VDD+0.3	V
OD output pin voltage	VOD	VSS-0.3 to VDD+0.3	V
CSI input pin voltage	VCSI	VDD-26 to VDD+0.3	V
Operating Temperature Range	TOP	-40 to +85	°C
Storage Temperature Range	TST	-40 to +125	°C

Note: FS312 contains a circuit that will protect it from static discharge; but please take special care that no excessive static electricity or voltage which exceeds the limit of the protection circuit will be applied to it.

\* Pulse ( $\mu$  sec) noise exceeding the above input voltage (VSS+12V) may cause damage to the IC.

## Electrical Characteristics

(VSS=0V, Ta=25°C unless otherwise specified)

PARAMETER	CONDITIONS	SYMBOL	Min	Typ	Max	UNIT
<b>CURRENT CONSUMPTION</b>						
Supply Current	VDD=3.9V	IDD		3.0	6.0	μ A
Power-Down Current	VDD=2.0V	IPD		0.3	0.6	μ A
<b>OPERATING VOLTAGE</b>						
Operating input voltage	VDD-VSS	VDS1	1.5		9.0	V
<b>DETECTION VOLTAGE</b>						
Overcharge detection voltage		VOCU	VOCU -0.025	VOCU	VOCU +0.025	V
Overcharge release voltage		VOCR	VOCR -0.050	VOCR	VOCR +0.050	V
Overdischarge detection voltage		VODL	VODL -0.080	VODL	VODL +0.080	V
Overdischarge release voltage		VODR	VODR -0.080	VODR	VODR +0.080	V
Over current detection voltage		VOI1	VOI1 -0.030	VOI1	VOI1 +0.030	V
Short circuit detection voltage	VDD=3.0V	VOI2	1.0	1.35	1.7	V
Reset resistance for Over current protection	VDD=3.6V	Rshort	400	500	600	kΩ
Charger detection voltage		VCH	-1.7	-1.35	-1.0	V
<b>DELAY TIME</b>						
Overcharge detection delay time	VDD=3.6V to 4.4V	TOC	50	100	150	ms
Overdischarge detection delay time	VDD=VODL+ 0.2V ~ VODL-0.2V	TOD	5	17	30	ms
Over current detection delay time	VDD=3.0V	TOI1	2	5	10	ms
Short circuit detection delay time	VDD=3.0V	TOI2		10	50	μ s
<b>OTHER</b>						
OC pin output "H" voltage	VDD=3.9V, Ioh=-50 μ A	Voh1	3.4	3.7		V
OC pin output "L" voltage	VDD=4.4V, CSI=0V	Vol1		0.1	0.5	V
OD pin output "H" voltage	VDD=3.9V, Ioh=-50 μ A	Voh2	3.4	3.7		V
OD pin output "L" voltage	VDD=2.2V, Iol=50 μ A	Vol2		0.1	0.5	V

## State Diagram of Operation

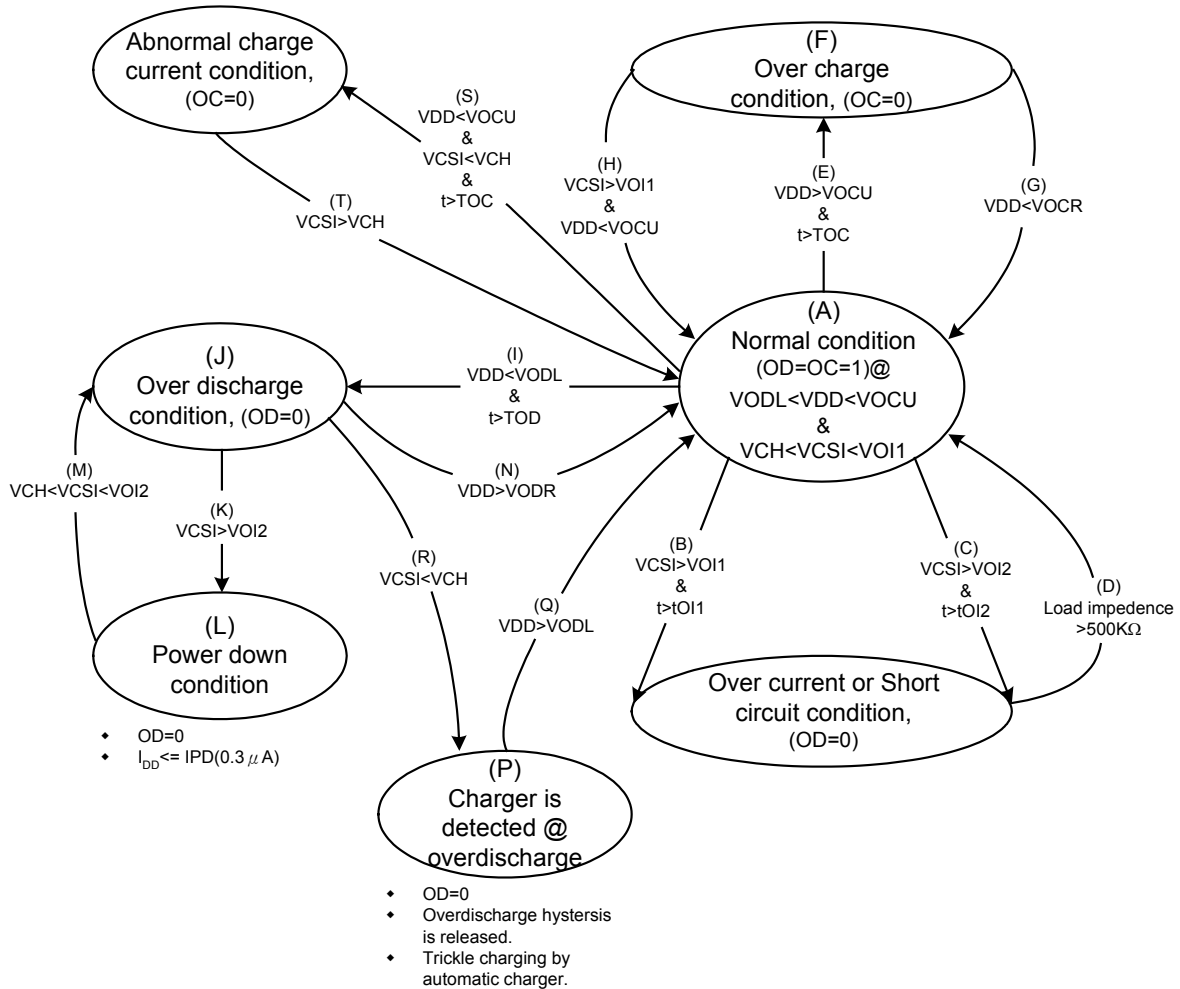

## Description of Operation

### 1. Normal Condition

If  $VODL < VDD < VOCU$  and  $VCH < VCSI < VOI1$ , M1 and M2 are both turned on. The charging and discharging processes can be operated normally.

### 2. Overcharge Detection

If the battery voltage detected from VDD reaches VOCU, charging from a charger is inhibited for overcharge protection. When VDD is larger than VOCU over a delay time of TOC, M2 will be turned off.

### 3. Release of Overcharge Condition

There are two ways to return to normal condition from overcharge condition.

- 1) When the battery is self discharging and  $VDD < VOICR$  occurs, M2 will be turned on and back to normal condition.
- 2) Remove the charger and connect FS312 to a load, the discharging current will flow through the parasitic diode of M2. While  $VOICR < VDD < VOCU$  and  $VCSI > VOI1$  occurs, M2 will be turned on and back to normal condition.

### 4. Overdischarge Detection

When the battery voltage falls below the overdischarge detection voltage (VODL) during discharging condition over a delay time of TOD, M1 will be turned off. In the meanwhile, CSI is pulled up to VDD by way of internal resistance. If  $VCSI > VOI2$ , FS312 will enter into power-down mode. (Its current consumption is lower than  $0.3 \mu A$ .)

### 5. Release of Power-Down mode

A charger is connected while the battery remains in Power-down mode. If  $VCH < VCSI < VOI2$  and  $VDD < VODR$  occurs, M1 is still be off but FS312 will release power-down mode. When  $VDD > VODR$  occurs, M1 will be turned on and back to normal condition.

### 6. Charger Detection

While connecting to a charger after entering into power-down mode, then if  $VCSI < VCH$ , M1 will be turned on when  $VDD > VODL$  and the system will back to normal condition.

### 7. Abnormal Charge Current Condition

When a charger is connected to the battery system in normal condition, then if  $VCSI < VCH$  occurs through a delay time longer than TOC (delay time of overcharge detection), M2 will be turned off to stop this charging status.

## 8. Over Current / Short Circuit Condition

When the current is too large during discharging under normal condition as a result of the voltage detected by CSI is greater than VO11 (or VO12) through a delay time longer than TO11 (or TO12), it satisfies the over current (or short circuit) condition. Then M1 will be turned off and CSI will be pulled down to VSS through an internal resistance.

- If the over current / short circuit is detected and it keeps longer than the overdischarge detection delay time with the same circumstance, the condition will be changed to power-down mode when the battery voltage falls below the overdischarge detection voltage.
- If the battery voltage falls below the overdischarge detection voltage (VODL) due to the over current / short circuit, the discharging control FET (M1) will be turned off when it has been detected. After overdischarge detection delay time (TOD) expired, if the battery voltage is still equal to or lower than the overdischarge detection voltage, the condition will then be changed to power-down mode.

## 9. Release of Over Current / Short Circuit Condition

While the protection IC remains in Over current / Short circuit condition, then if the load is removed or the impedance between VBAT+ and VBAT- is larger than  $500k\Omega$  as well as  $V_{CSI} < V_{O11}$ , M1 will be turned on and then back to normal condition.

**Note: When a battery is connected to FS312 for the first time, it may not enter the normal condition (dischargeable may not be enabled). In this case, short the CSI and VSS pins or connect to a charger to restore to the normal condition.**



## Timing Diagram

### 1. Overcharge Condition → Self Discharge → Normal Condition

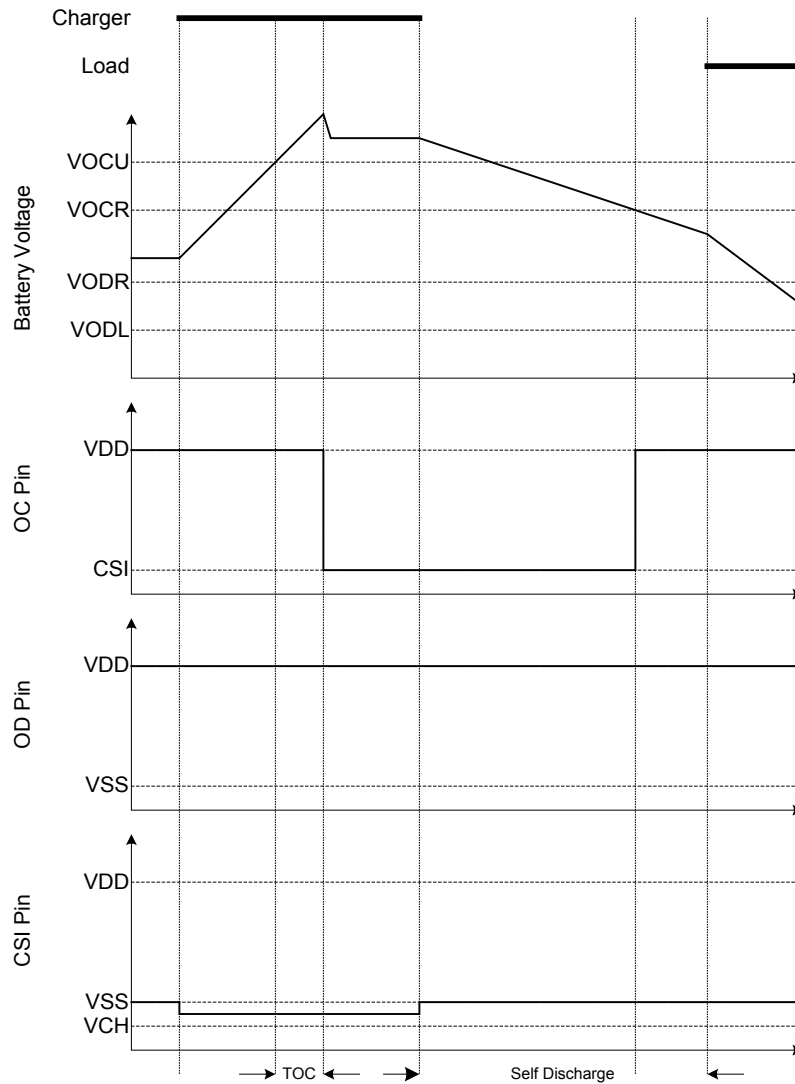

**2. Overcharge Condition → Load Discharge → Normal Condition**

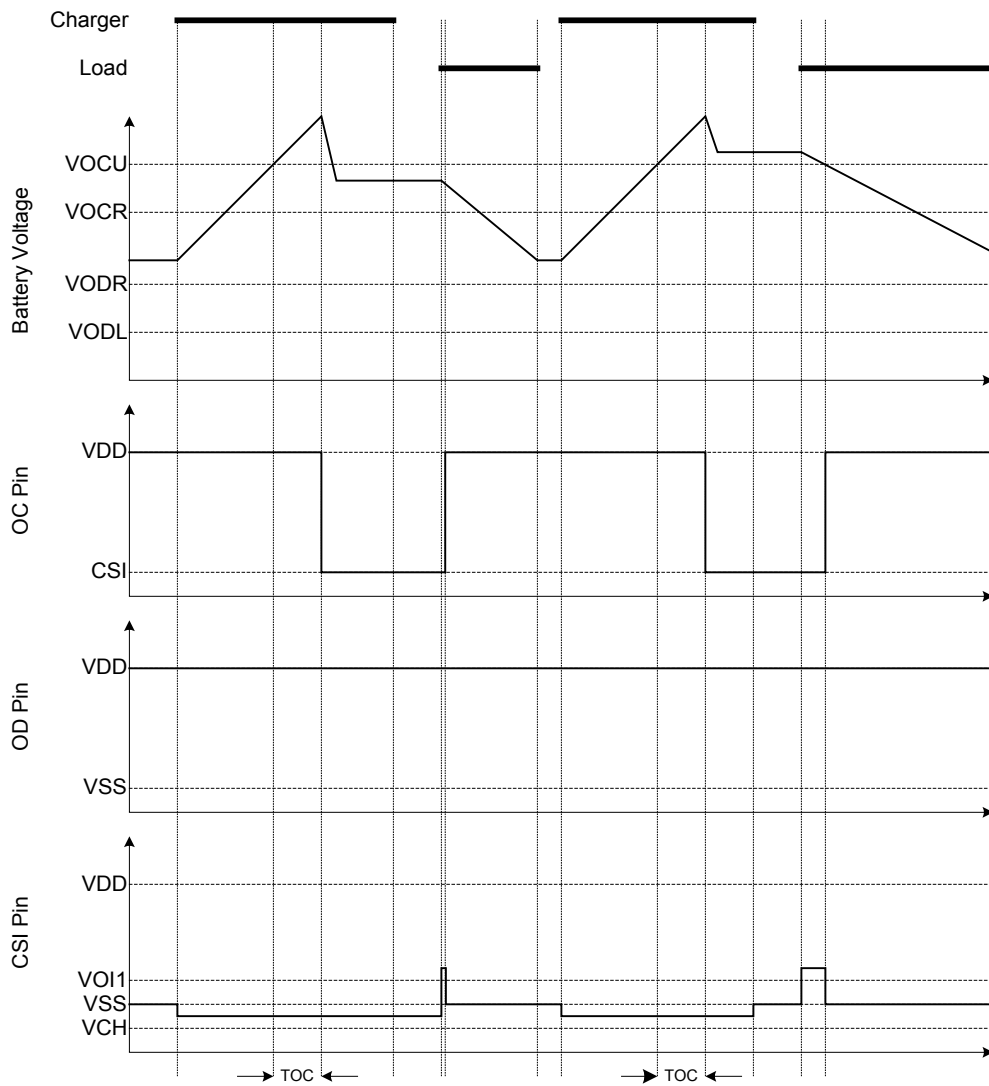

**3. Overdischarge Condition → Charging by a Charger → Normal Condition**

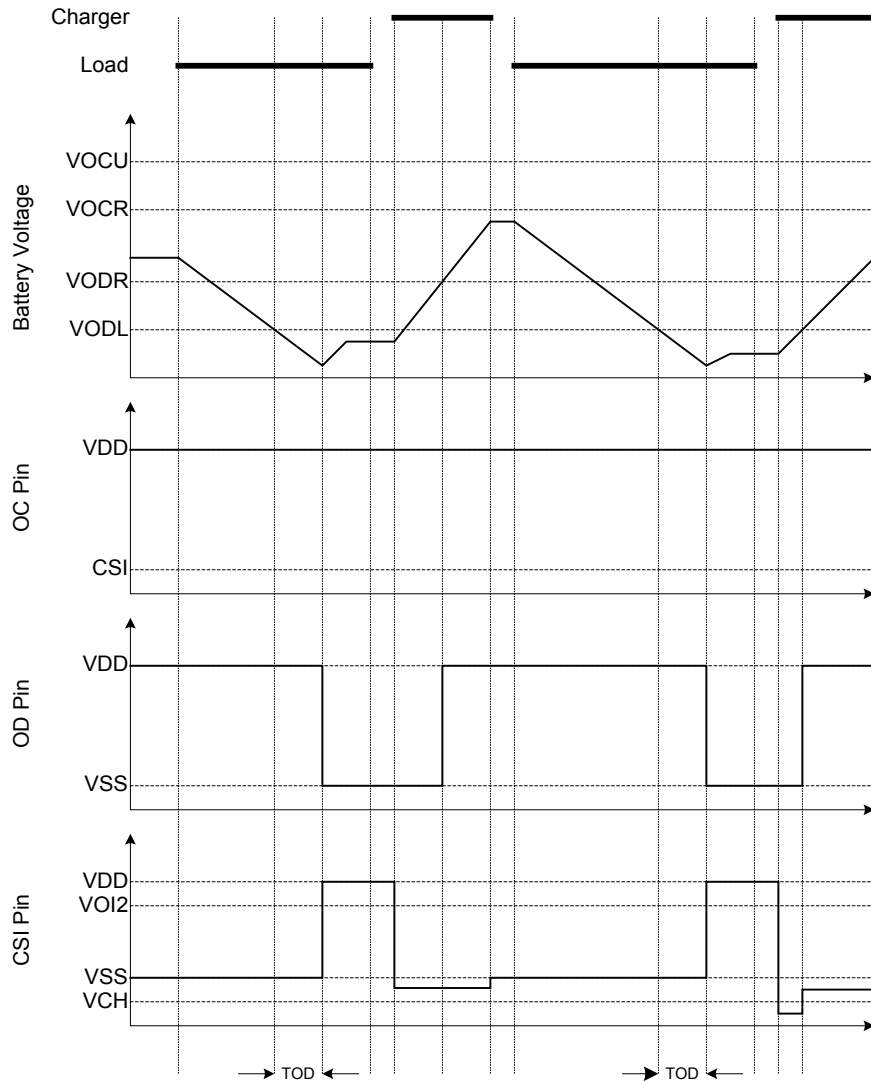

**4. Overdischarge Condition → Abnormal Charging → Normal Condition**

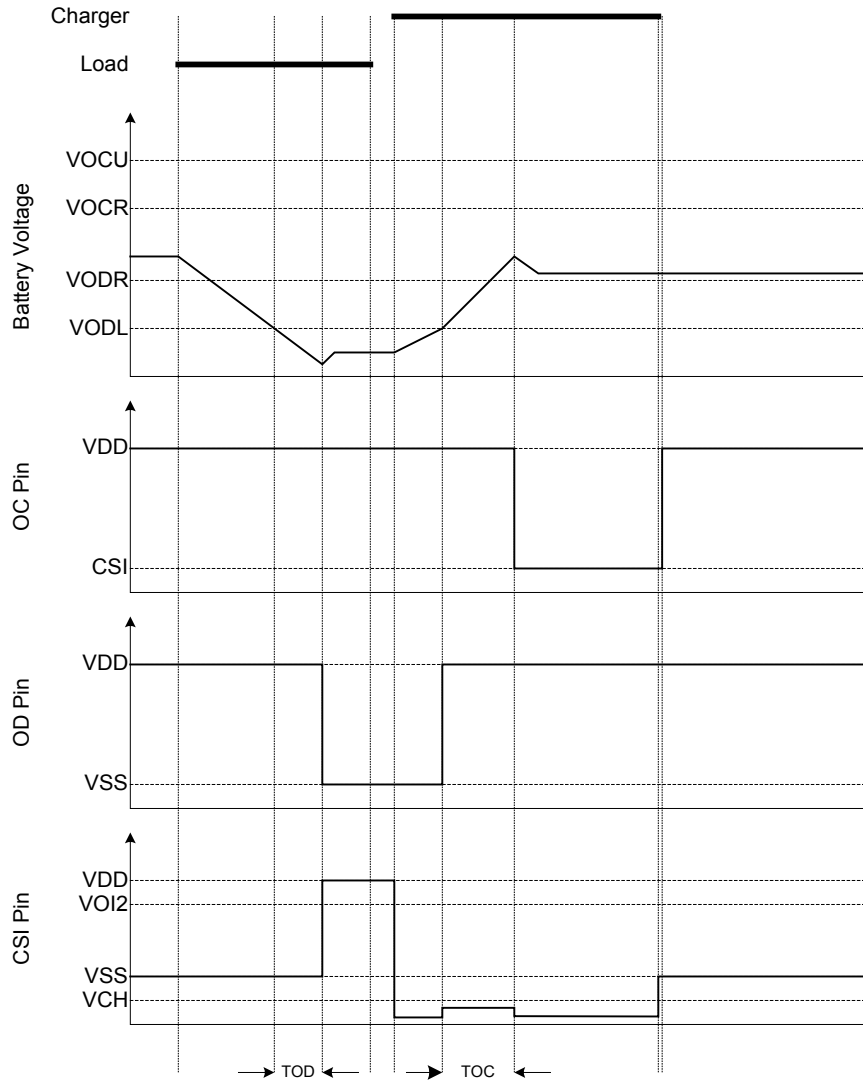

**5. Overcurrent / Short circuit Condition → Normal Condition**

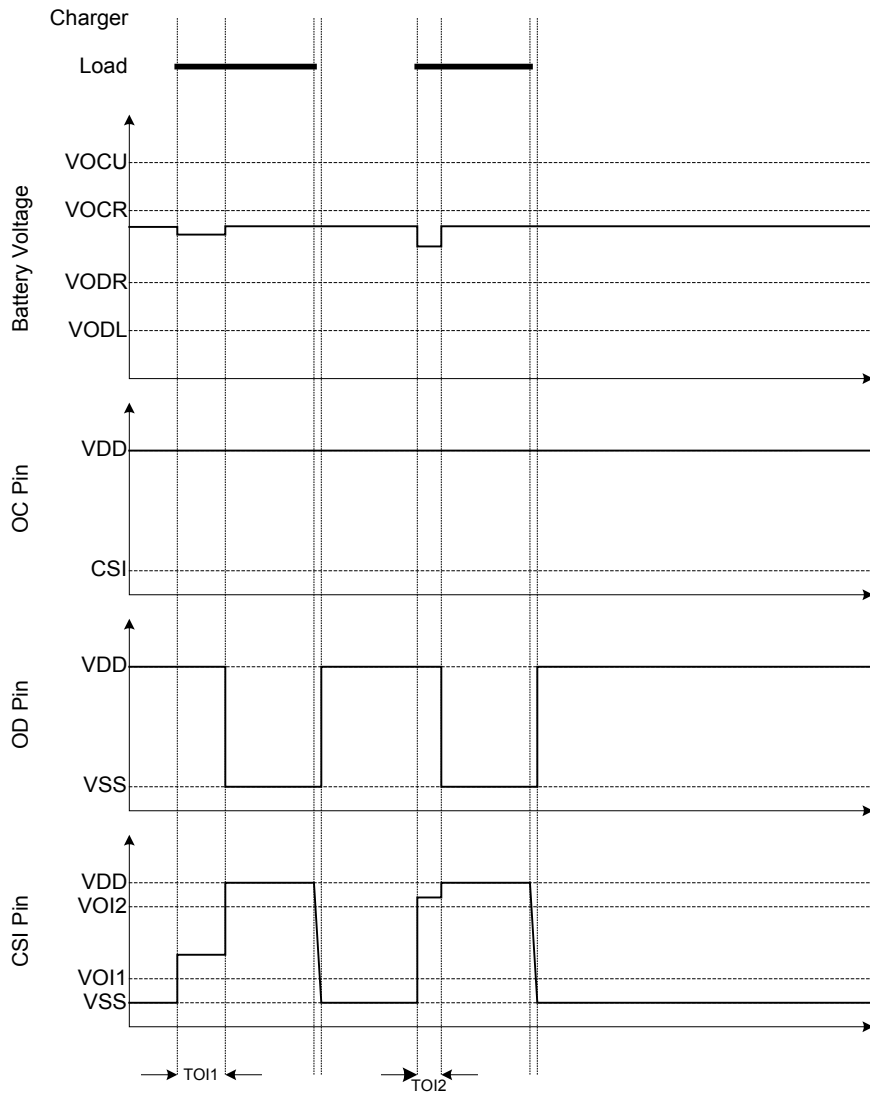

## Package Outline

### Dimension (Package A)

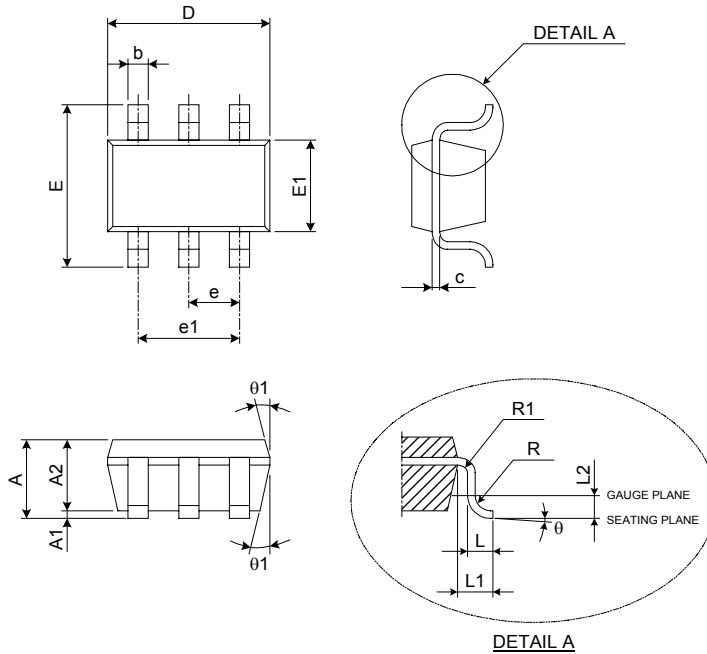

Unit : mm

SYMBOL	MIN.	TYP.	MAX.
A	-	-	1.45
A1	-	-	0.15
A2	0.90	1.15	1.30
b	0.30	-	0.50
c	0.08	-	0.22
D	2.90 BSC.		
E	2.80 BSC.		
E1	1.60 BSC.		
e	0.95 BSC.		
e1	1.90 BSC.		
L	0.30	0.45	0.60
L1	0.60 REF.		
L2	0.25 BSC.		
R	0.10	-	-
R1	0.10	-	0.25
θ	0°	4°	8°
θ1	5°	10°	15°

### Dimension (Package B)

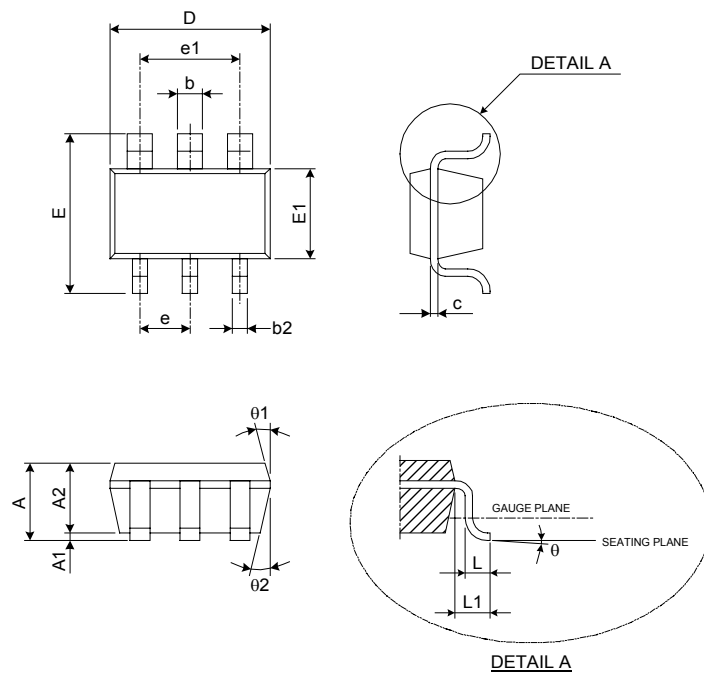

Unit : mm

SYMBOL	MIN.	TYP.	MAX.
A	1.05	-	1.35
A1	0.05	-	0.15
A2	1.00	1.10	1.20
b	0.40	-	0.55
b2	0.25	-	0.40
c	0.08	-	0.20
D	2.70	2.90	3.00
E	2.60	2.80	3.00
E1	1.50	1.60	1.70
L	0.35	0.45	0.55
L1	0.60 REF.		
e	0.95 BSC.		
e1	1.90 BSC.		
θ	0°	5°	10°
θ1	3°	5°	7°
θ2	6°	8°	10°