

INSPIRE
INTERACTIVE NASA SPACE PHYSICS
IONOSPHERE RADIO EXPERIMENTS



INSPIRE VLF-3 Receiver Kit Assembly Instructions

VLF-3 Rev #1C Receiver Kit

A publication of The INSPIRE Project Inc.
Photo courtesy of Tony Bateman (Finland)

INSPIRE VLF-3 Rev #1C Receiver Kit

ASSEMBLY INSTRUCTIONS

The following assembly instructions should be followed carefully. The INSPIRE VLF-3 receiver kit is NOT a simple electronic assembly. If you follow the instructions carefully you should be successful in building a receiver that works. If you are not careful, you run the risk of having a problem that is very difficult to locate and fix.

TOOLS NEEDED:

- Philips head screwdriver
- Small standard screwdriver
- Wire cutters
- Wire stripper
- Soldering iron (15-25 watt, small tip)
- Light duty resin core solder (60/40)
- Sponge
- Magnifying glass
- Solder sucker or solder wick



KIT CONTENTS:

- 1. Black plastic enclosure
- 2. Face Plate
- 3. Printed Circuit Board (PCB)
- 4. Four bags of components:

- Bag 1 resistors, inductors
- Bag 2 capacitors
- Bag 3 ICs, diodes, sockets
- Bag 4 switches, jacks, knobs, antenna terminal, wires, miscellaneous hardware



Faceplate

Front Control Panel



Printed Circuit Board (PCB):

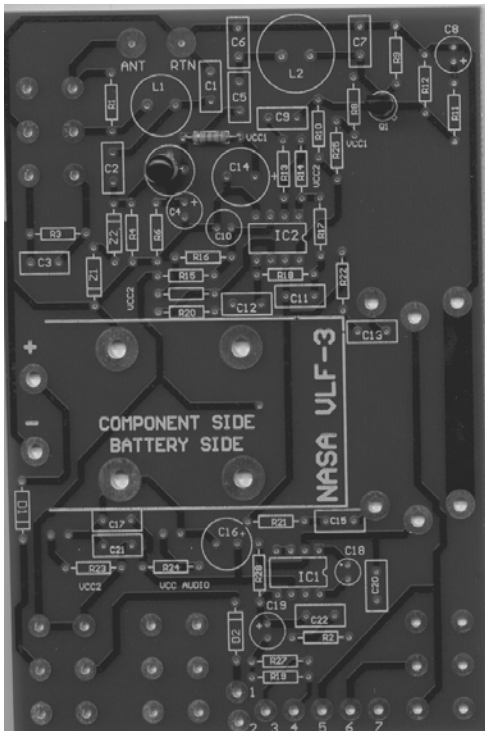

Component Side / Battery Side

All electronic components are inserted from this side and soldered on the other side. The battery holder is inserted from this side also.

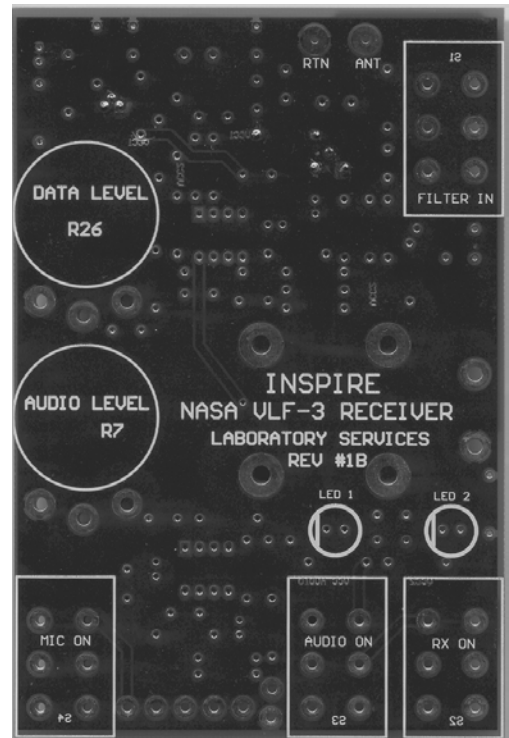

Switch Side

The four DPDT slide switches, the two 10k pots and the two LEDs are inserted from this side and soldered on the other side.

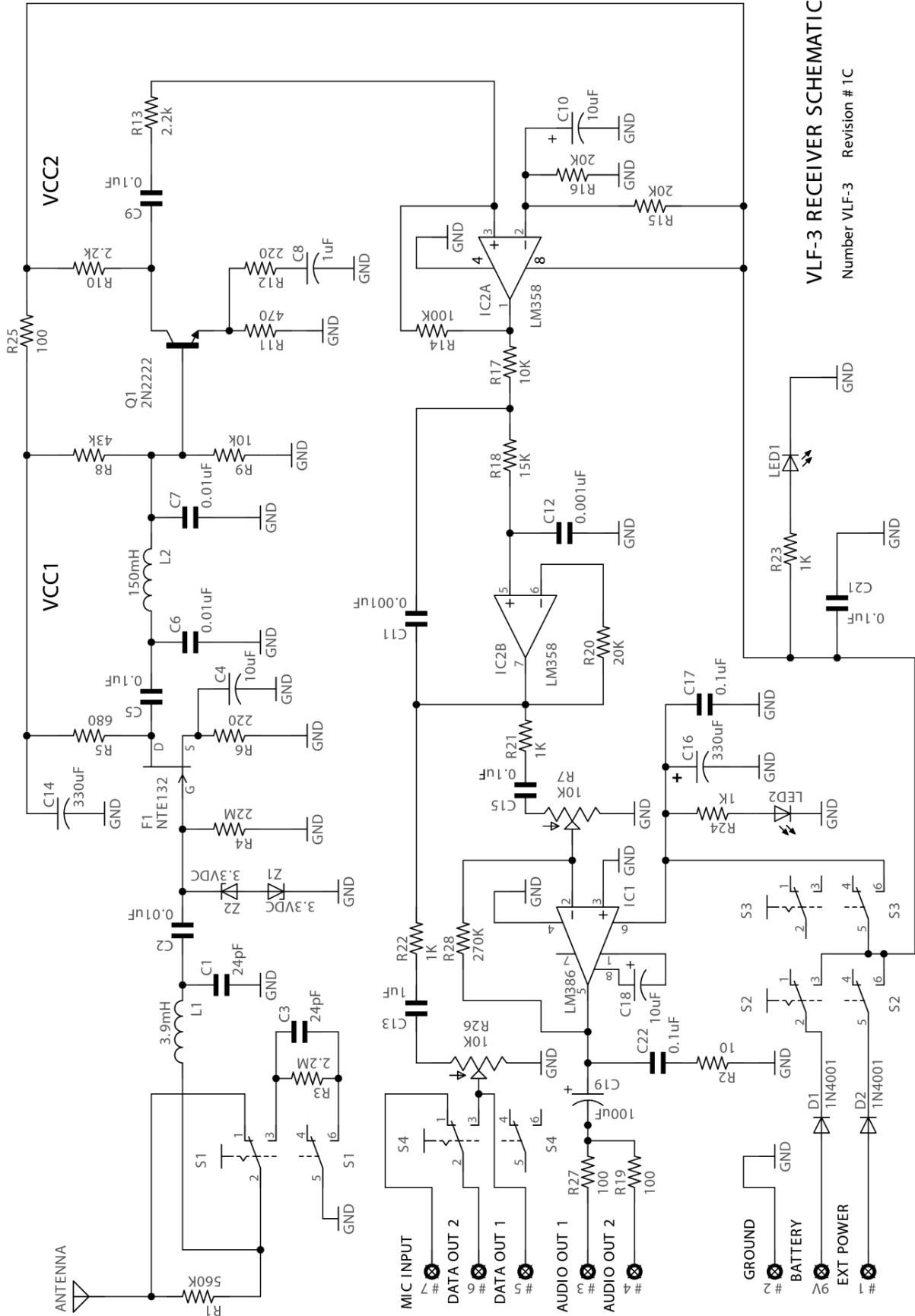

Instructions Outline

- 1. Solder components to the Printed Circuit Board (PCB)**
- 2. Connect wires to PCB**
- 3. Install jacks and connectors to the faceplate**
- 4. Attach the PCB to the faceplate**
- 5. Solder wires to jacks and connectors**
- 6. Test receiver**
- 7. Diagnostics Guide – First Steps**

(Check off boxes as each step is completed)

1. SOLDER COMPONENTS TO Printed Circuit Board (PCB)

These instructions refer to assembling the INSPIRE VLF3 receiver kit with the PCB marked on the edge as "NASA VLF-3 REV #1C". A few things need to be noted before you begin assembly.

- 1) The transistor (Q1) and the field effect transistor (J-FET with ferrite bead) have been preinstalled.
- 2) Capacitor C20 has a place for it screen printed on the PCB, **but it is not to be populated**. Leave that location on the PCB empty.
- 3) Capacitor C12 needs additional attention for it to be installed correctly. A PCB trace is missing from the side of C12 nearest R20, which should have connected this end to ground. To fix that you will need to scrape of a small part of the green coating on the trace that runs directly under C12 and connect this lead to that ground trace when you install C12. Check out the three pictures below. The first is centered on the location with an arrow pointing to the lead in question. The second shows some of the insulating green coating removed, and the third shows how the lead from C12 can be bent over for soldering to the ground trace. It is a simple fix if you are patient and careful.



- 4) Variable resistors (potentiometers) R7 and R26 are installed on the non-component side of the PCB after the other small components are installed. Note that there is a small tab that may protrude from the potentiometer body that will need to be removed if present. The picture below shows one of them with the tab noted. To remove the tab, grab it with pliers and bend back and forth at the base until it breaks away at the base.

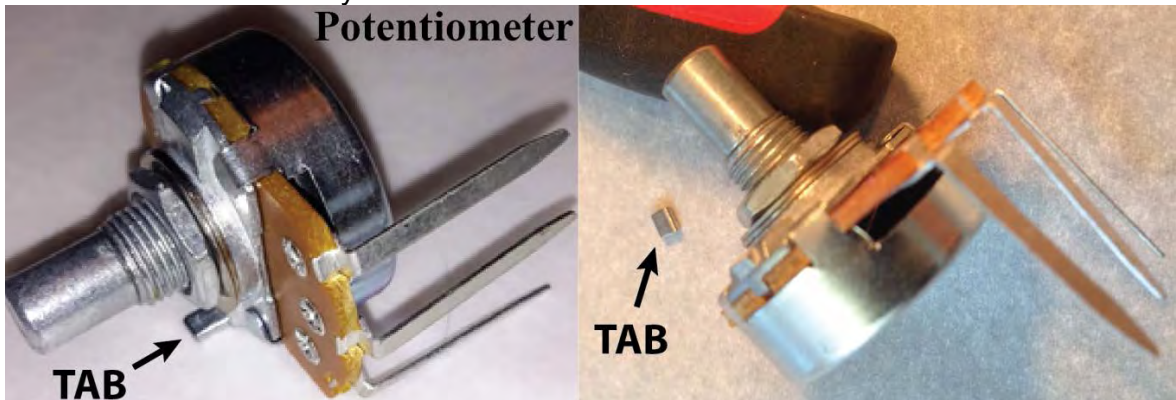

- 5) Let's take some time to talk about soldering. If you are comfortable with soldering, skip along to the next section and have at it. If not, let's start with a brief overview of how to solder.

STEPS FOR SOLDERING RESISTORS, CAPACITORS AND WIRES

IMPORTANT:

DO NOT leave a soldering iron plugged in for a long time without using it.
NEVER leave a hot soldering iron unattended.

1. Clean the tip of the iron by wiping it on the wet sponge.
2. Place a small amount of solder on the tip.
3. Press the tip down against the circuit contact and against the resistor lead and hold for 5 seconds.
4. After the lead and the contact have heated for 5 seconds, apply the solder to the lead and contact (NOT directly to the iron) until the solder melts and flows around the lead and into the contact.
5. Apply enough solder to allow it to run down along the lead. Do not apply so much solder that it runs across the PCB surface.
6. After enough solder has been applied (1-2 seconds), remove the solder wire but hold the iron in place for another 2-3 seconds.
7. Remove the iron, allow the joint to cool and inspect the joint.
8. Trim the excess lead wire just above the solder joint.

Repeat this process for the remaining resistors.

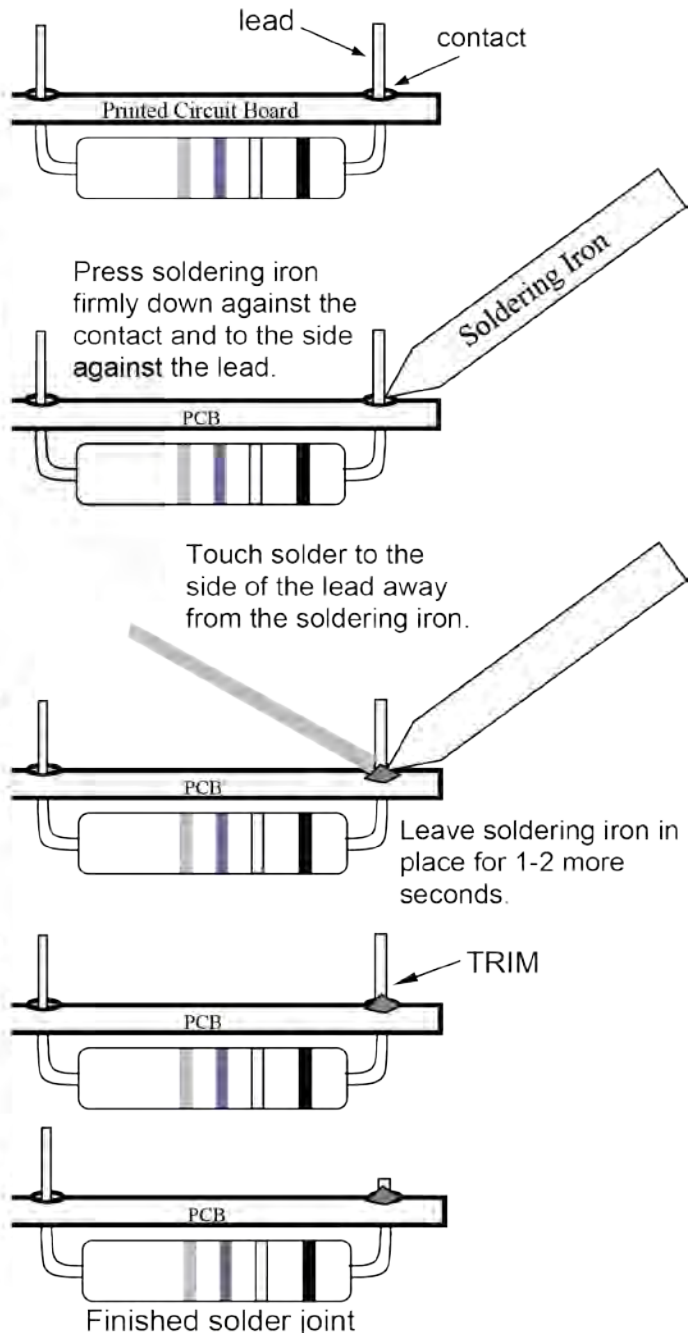

IMPORTANT Note for New Soldering Irons:

A new soldering iron must be “tinned” in order to work well. Follow these steps:

1. Plug in the iron.
2. When it first heats up, apply solder liberally to the tip.
3. Wipe off the excess solder onto a damp sponge and you are ready to go!

When done soldering a joint, the solder should be shiny and appear to wet or adhere to the component lead and onto the copper pad on the PCB (a concave shape). If the solder curves inward or beads up away from either, a convex shape, then that might be a cold-solder joint where there is not a good electrical connection between the parts. Too much solder will be bulbous at the joint. Insufficient heat to the wire or PCB will result in solder not flowing onto the metal to make good contact. Solder is used to make that good electrical connection; it is not good for making a strong mechanical connection. If necessary, briefly reheat the component lead and copper pad to try to flow the solder. If necessary add a very small additional amount of solder, but avoid prolonged contact with the soldering iron or you may damage the component or PCB copper pad. You will likely see an amber colored brittle material near joints you have soldered. That is rosin that is inside the solder to begin with. It helps the solder to wet or adhere to the lead and copper pad. It can be scraped away gently if you want to clean up the job after finished. The solder you use should be for PCB use, not plumbing on copper pipes. The PCB variety has a very small diameter, perhaps a millimeter. The plumbing kind might be 3mm in diameter. Don't go to a plumbing supply place to get solder for electronics. Also, do not use a soldering gun for this work; it gets too hot. Use a 15-25 Watt soldering iron. It takes little heat to do this, though more than enough to burn yourself. If you happen to splash liquid solder onto yourself, fear not. It will hurt, but only briefly and not with much consequence to your skin usually. This isn't like having hot glue wick onto your finger. Trust me, you do not want to experience that. Learn from my mistakes young Padawan.

1a. Sort and Install Resistors

Remove the resistors from Bag 1. Leave the inductors for later installation.

The colored bands on the resistors indicate the resistance using a color code. This table indicates how to convert each color to its numerical equivalent.

- 0 black
- 1 brown
- 2 red
- 3 orange
- 4 yellow
- 5 green
- 6 blue
- 7 violet
- 8 gray
- 9 white

gold: 5% tolerance

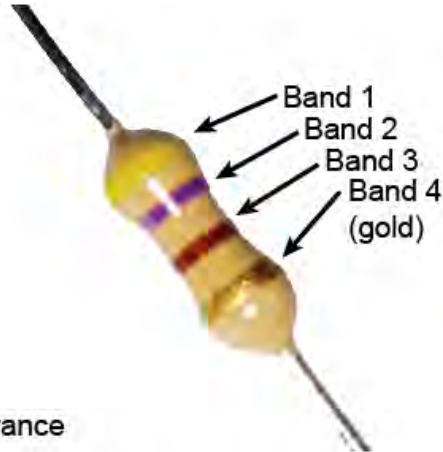

To read a resistor code, first locate the gold band and read the colors in order from the other end. (All resistors in this kit have a gold band indicating 5% tolerance.) The first two bands indicate digits in the resistance, the third band (called the multiplier) indicates the number of zeroes to be added to the digits to obtain the resistance.

(NOTE: 1000 = kilo = k ; 1,000,000 = mega = Meg)

What is the resistance for each of the following?

	Example 1	Example 2	Example 3	Example 4
Band 1	brown	yellow	red	orange
Band 2	black	violet	black	orange
Band 3	brown	orange	green	orange
Band 1	1	4	2	3
Band 2	0	7	0	3
Band 3	1	3	5	3
Resistance	100 100 Ω	47000 47 kΩ	2000000 2 MegΩ	33000 33 kΩ

Bag 1 Contents	
Resistors:	
R1	560 kΩ
R2	10 Ω
R3	2.2 MegΩ
R4	22 MegΩ
R5	680 Ω
R6, R12	220 Ω
R7, R26	10k pots in Bag #4
R8	43 kΩ
R9, R17	10 kΩ
R10, R13	2.2 kΩ
R11	470 Ω
R14	100 kΩ
R15, R16, R20	20 kΩ
R18	15 kΩ
R19, R25, R27	100 Ω
R21, R22, R23, R24	1 kΩ
R28	270 kΩ
Inductors:	
L1	3.9 mH
L2	150 mH

Use the resistor code to identify and sort all of the resistors. One good way to keep them sorted is to tape one end to a piece of paper and write the resistance and component number (R1, R2, etc.). Once you have identified and sorted all of the resistors, you are ready to solder them to the PCB.

Care should be used in identifying R3 (2.2 Meg Ω) and R4 (22 Meg Ω). The green band and the blue band can look similar. For best results, identify both components together so differences can be noted.

To prepare a resistor for insertion into the board, bend the two leads so that they form a right angle to the resistor body.



Resistor locations on the component side of the PCB are indicated with the “R” number from the parts list between the two holes for insertion of the leads.

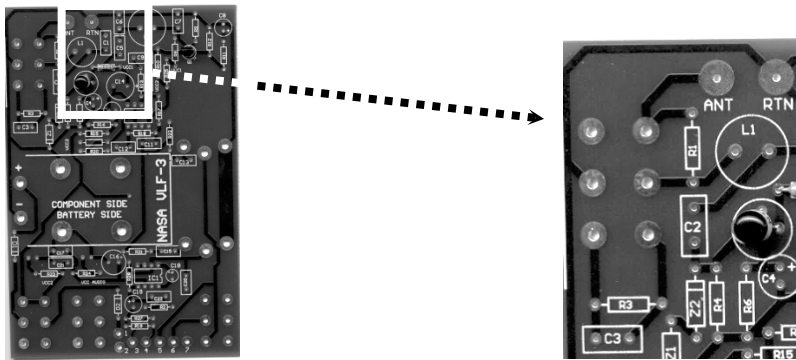

Part of the PCB showing location of R1, R3, R4 and R6

To install, place the leads of the resistor through the appropriate holes and press the resistor down against the component side of the PCB. There is no required orientation for resistors. Either lead may be inserted in either hole. Turn the board over while holding the resistor in position and bend the leads slightly outward to hold the resistor in place and solder the leads to the circuit side. Feel free to insert all the resistors at once or in groups like that shown below and then solder the leads for each in the group and trim before going on.

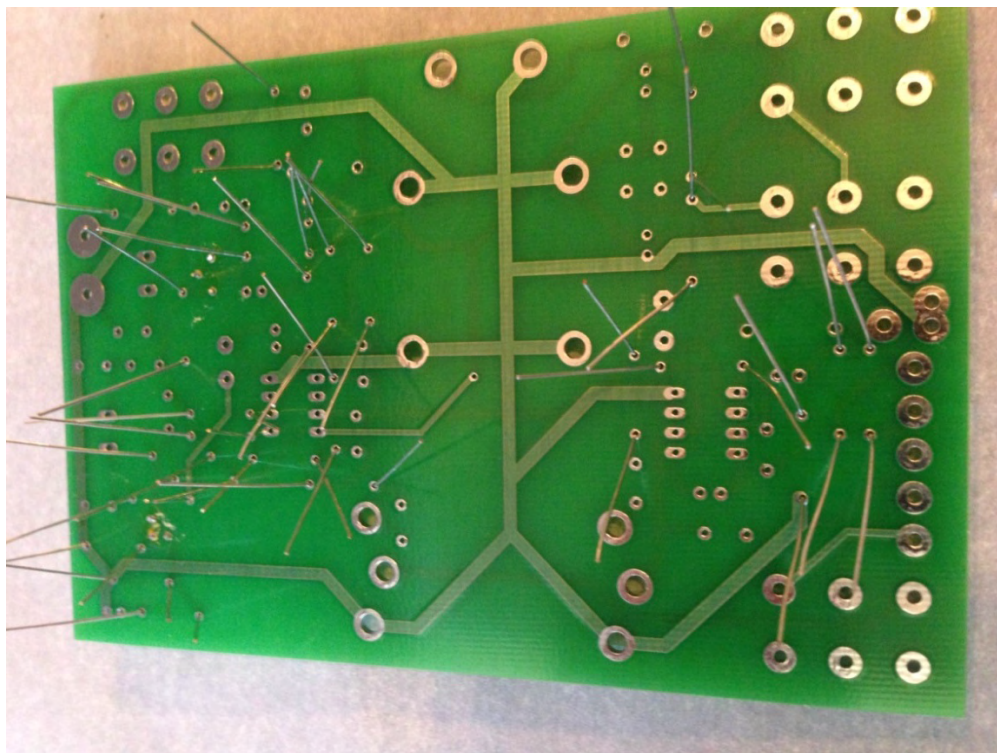

After installing the resistors you will have something like the following picture. The other small components are similarly installed, however the diodes and some of the capacitors must be installed with the correct orientation, which is described below.

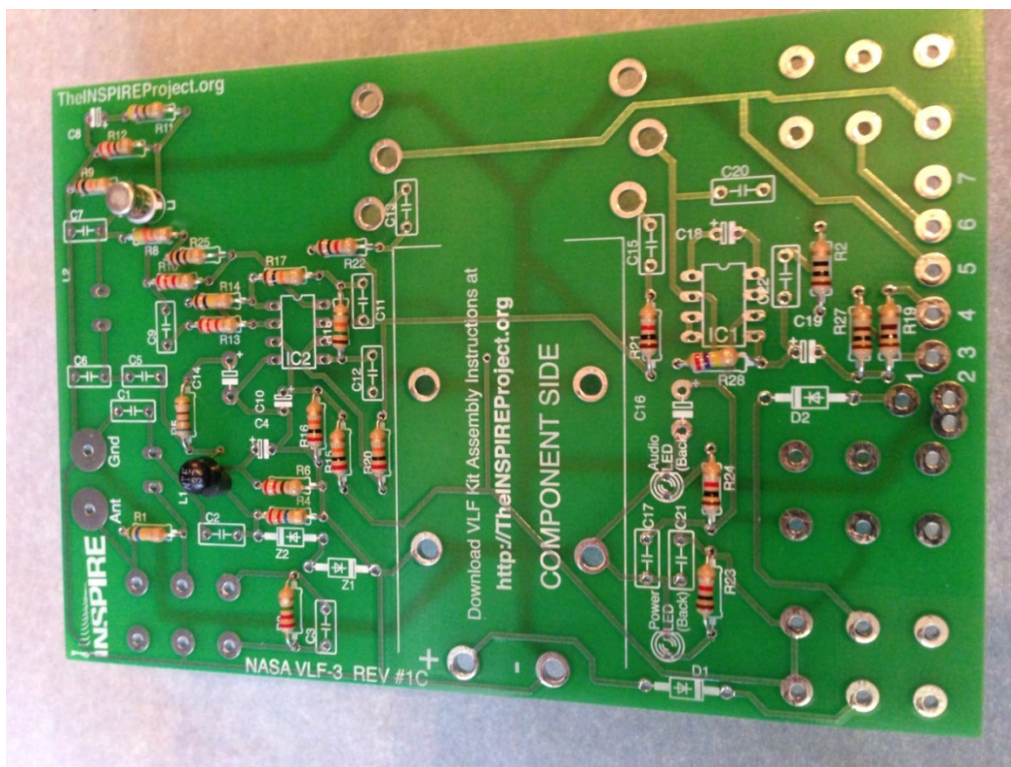

1b. Install the IC sockets

Remove the IC sockets and IC1 (LM386) and IC2 (LM358) from Bag #3. When installing IC sockets and ICs, alignment is very important. One end of the IC symbol on the PCB has a half-hole at one end of the symbol. One end of the socket has a half-hole. The IC itself has a circular dot near one end.

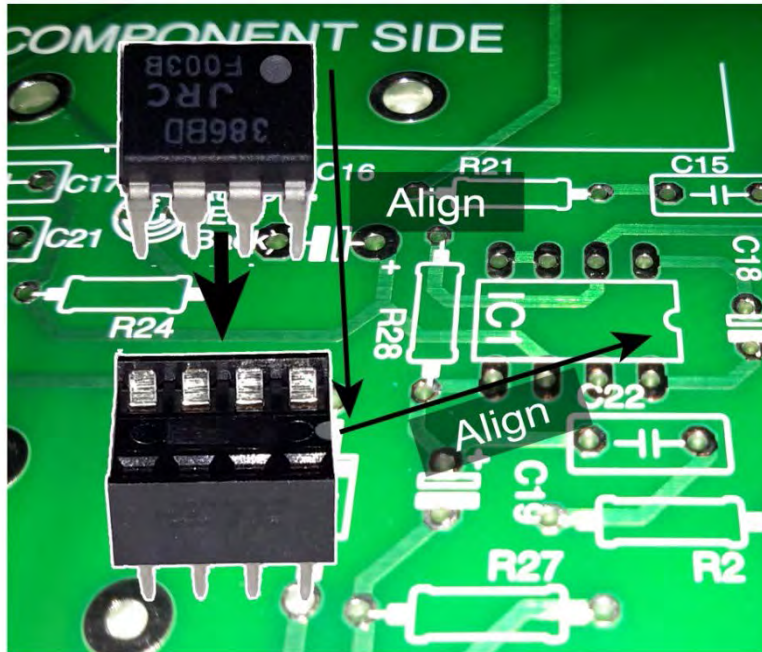

Install the sockets so that the half-hole end coincides with the half-hole on the PCB. Press the sockets firmly against the component side of the PCB. Solder the 8 pins on the other side of the PCB taking care not to create any solder “bridges” between the pins.

Install the IC so that the end with the dot is at the end of the socket with the half-hole. Carefully fit the 8 pins in the socket holes and press the IC firmly into the socket. Note that the IC pins come to you slightly spread apart. That is normal, but without bending them to be more perpendicular to the body, they will be hard to match up to the socket holes for insertion. The picture below shows one of the ICs before and after bending the legs. To bend the legs hold each IC on its side with its leg’s flat against a table and gently rotate the body to bend all the legs on one side at the same time. Turn it over and do the same to the other side.

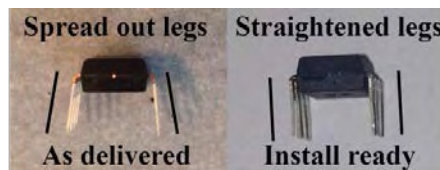



1c. Solder capacitors to the PCB

Capacitor Identification Guide

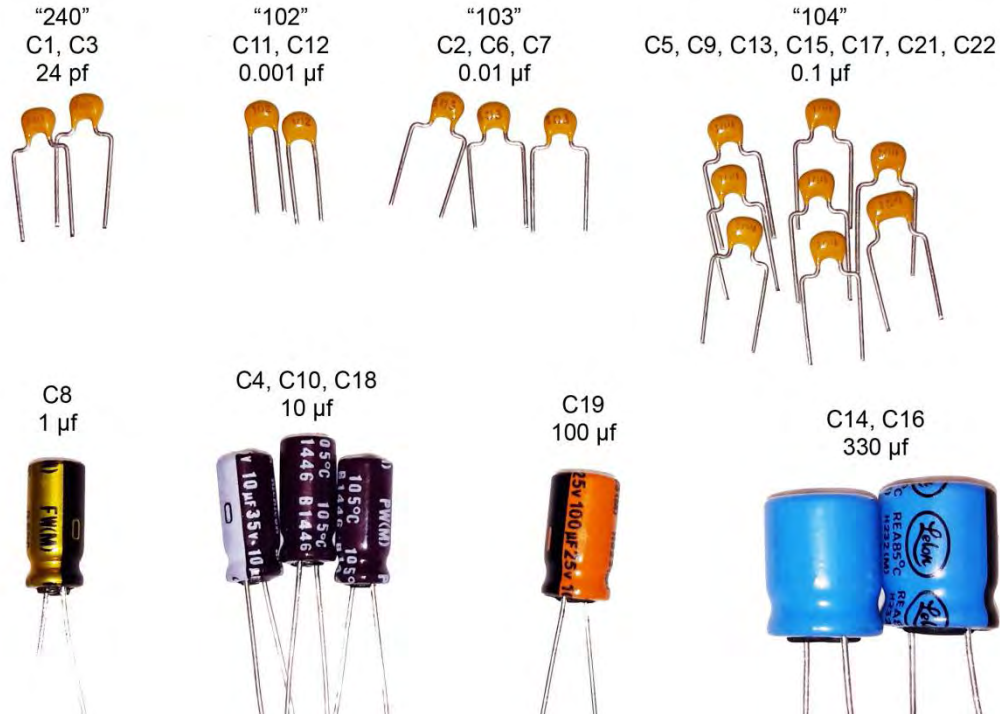

The small-value ceramic capacitors may be installed in either orientation, but the larger-value cylindrical capacitors (C4, C8, C10, C14, C16, C18, C19) must be installed with the proper polarity.

- 240 = 24 pF
- 102 = 0.001
- 103 = 0.01
- 104 = 0.1

The polarity is indicated on the PCB by a “+” sign near one end of the capacitor location. The polarity is indicated on the body of the capacitor with a stripe with a minus (-) sign located on the negative side of the capacitor. Also, the shorter lead is the negative lead.

Bag #2 Contents	
Capacitors:	
C1, C3	24 pF
C2, C6, C7	.01 µF
C4, C10, C18	10 µF
C5, C9, C13, C15, C17, C21, C22	.1 µF
C8	1 µF
C11, C12	.001 µF
C14, C16	330 µF
C19	100 µF

To install a capacitor, insert the leads in the appropriate holes and press the capacitor down near the PCB. Solder using the same technique as used for resistors. The polarity is not marked on the component side of the board for capacitor C10. The proper polarity is indicated here.

NOTE: There may be some variation in capacitor markings due to using different suppliers.

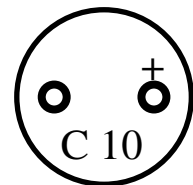

1d. Install the inductors (L1 and L2)

The inductors are the two remaining parts in Bag #1. Inductor L1 is marked “392J”. Inductor L2 is marked “154J”. From the component side, press the inductor firmly down against the PCB and solder the other side. There is no required polarity for the inductors.



1e. Install the diodes from Bag #3

Polarity is very important in the installation of diodes.

D1 and D2 are black cylinders with a silver stripe near one end.



On the PCB, the D1 and D2 locations are shown as a rectangle with a stripe near one end.

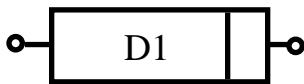

Remaining Bag #3

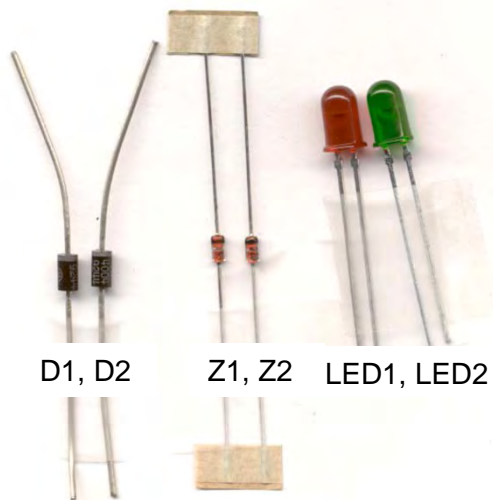

Align the striped end of the diode with the striped end of the PCB symbol. Press the diode firmly against the component side of the PCB and solder the other side.

Z1 and Z2 are small components with a black stripe near one end. The symbol on the PCB is the same as for D1 and D2. As with D1 and D2, align the black stripe end with the striped end on the PCB. Press the diodes firmly against the PCB and solder the other side.

Return the LEDs to Bag #3. They will be installed later.

1f. Install the battery holder

From Bag #4, take the following parts:

- 1 Battery holder
- 2 PCB standoff post
- 2 4-40 3/8 " screw
- 4 4-40 1/4" screw
- 2 4-40 nuts
- 2 nylon washers
- 2 #4 washers

The following diagram shows the assembly of the battery holder to the PCB:

1. Place the battery holder leads through the PCB from the component side and press the holder firmly against the PCB.
2. Insert 1/4" screws through the holes nearest the leads, through the PCB and tighten the nuts on the switch (solder) side.
3. Insert 3/8" screws through the other two holes, through the PCB, through the nylon washers and tighten the standoffs on the switch (solder) side.
4. Solder the battery leads on either (or both) side of the PCB.
5. Temporarily insert 1/4" screws through the #4 washers in the other ends of the standoffs. These will be used later to attach to the faceplate.

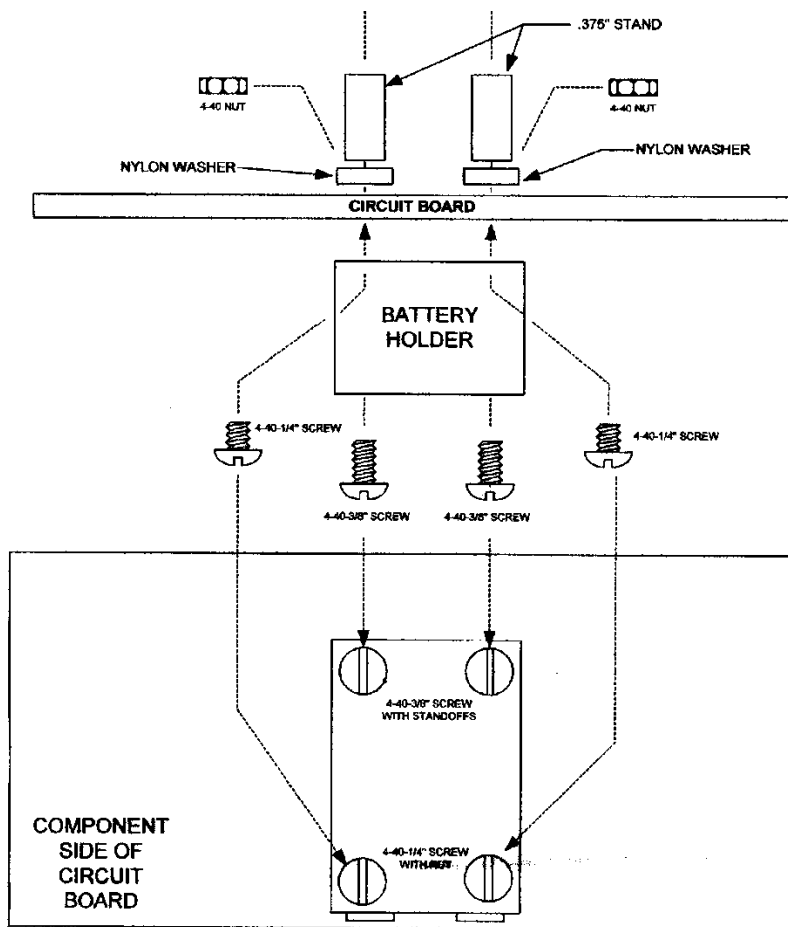

1g. Install the potentiometer and switches

From Bag #4, remove the two 10k pots (R7 and R26) and the four Double Pole Double Throw (DPDT) slide switches.

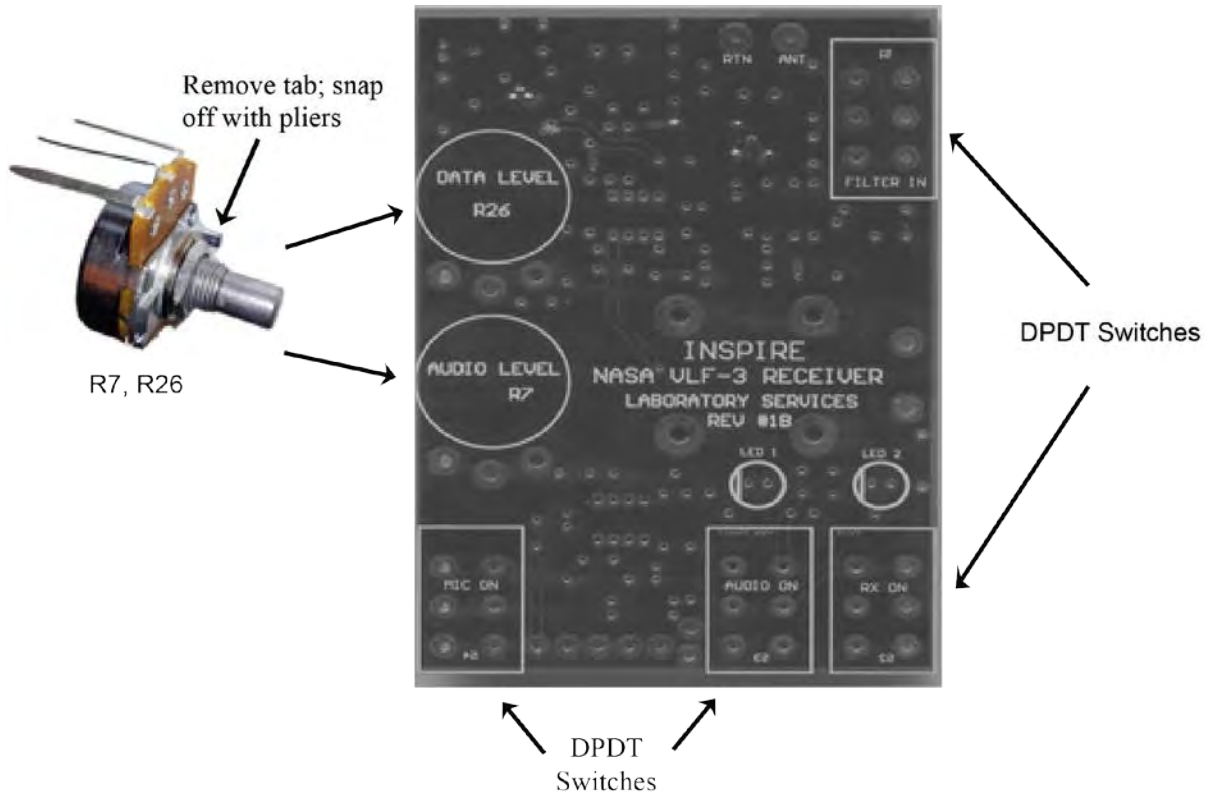

Slide the three contacts for the pots through the holes provided from the switch side of the PCB (non-component side). Push the switch firmly against the PCB and solder either (or both) sides.

Insert the six contacts for each DPDT slide switch into position and press the switch firmly against the switch side of the PCB. Solder each contact on the component side.

1h. Install the LEDs

Align the LED leads as shown with the shorter lead closest to the line in the PCB symbol. Either color can be used for LED1 and LED2 even though red is shown as LED1 and green as LED2 on pages 9 and 13.

Insert the LEDs and place the PCB against the face plate, letting it push the LEDs into the PCB. Adjust until they only protrude slightly above the surface of the face plate, then solder in place to either side of the PCB.

Carefully trim the excess leads.

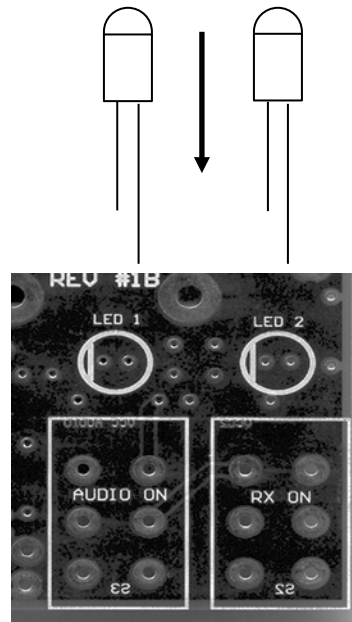

2. ATTACH WIRES TO THE PCB

Bag #4 contains the following wires:

- 3" red
- 4" orange
- 4" yellow
- 3" blue
- 3" black
- 5" white

Cut each color wire to produce the following lengths (the blue wire is not cut):

- 1 red: 1", 2"
- 1 orange: 2", 2"
- 1 yellow: 2", 2"
- 1 blue: 3"
- 1 black: 1", 2"
- 1 white: 2", 1.5", 1.5"

To prepare a wire for soldering, strip about 1/8" of insulation from each end. To solder a wire to the PCB:

1. Insert the wire into the component side,
2. Press the soldering iron to the wire and to the metal pad on the PCB for about 5 seconds to heat both the wire and the pad,
3. Apply solder to the wire side away from the soldering iron making sure that the wire and pad melt the solder, not the soldering iron.

Solder the 1" red wire to the ANT connection on the PCB.
Solder the 1" black wire to the RTN connection on the PCB.

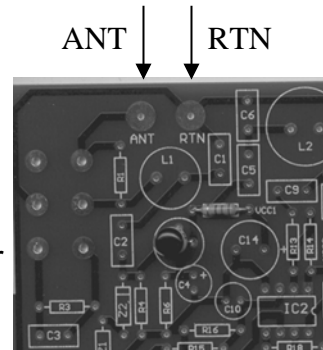

The wire connections to the PCB are numbered 1-7.
Connect the following wires to the appropriate locations:

- Connection 1: 2" red wire
- Connection 2: 2" black wire and 2" white wire twisted together
- Connection 3: 2" orange wire
- Connection 4: 2" orange wire
- Connection 5: 2" yellow wire
- Connection 6: 2" yellow wire
- Connection 7: 3" blue wire

See photos on the following page.

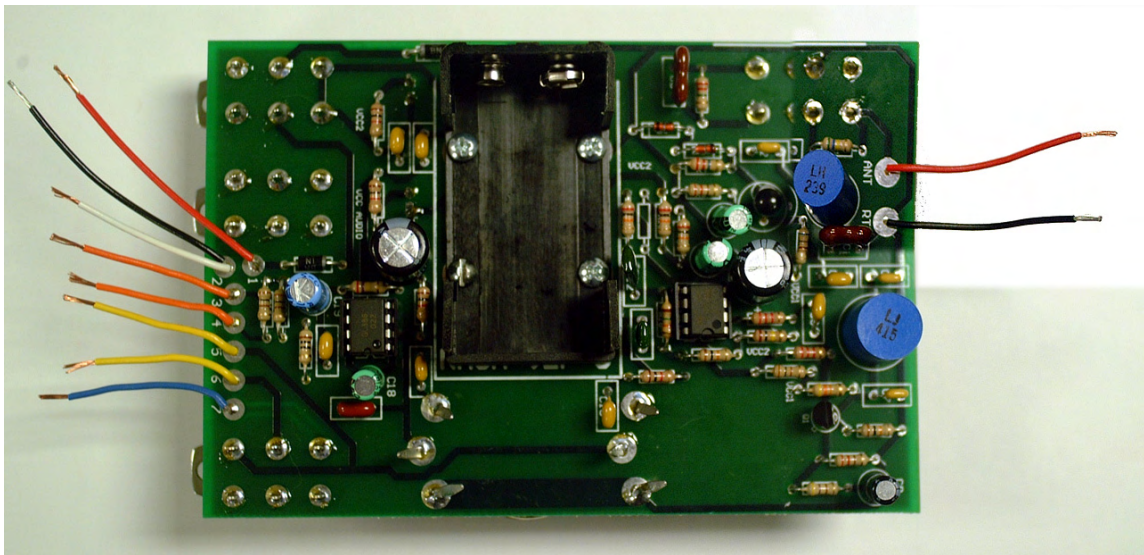

Wires installed (component-side view)

Close up of white and black wire twisted together prior to being soldered to location #2 on the PCB

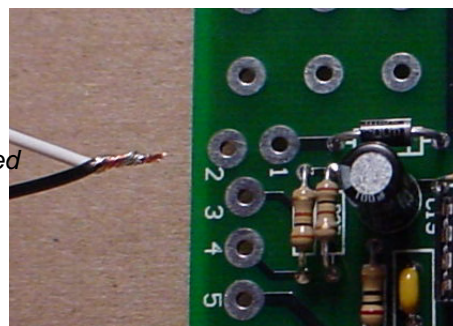

Wires installed (switch-side view)

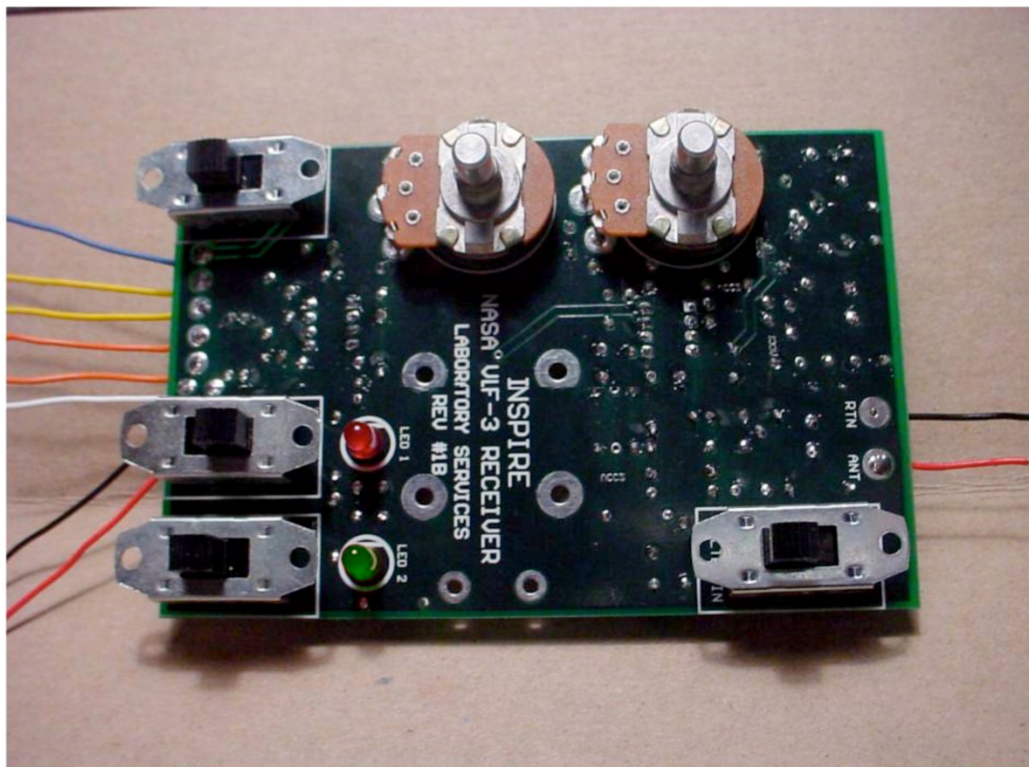

3. INSTALL THE JACKS AND CONNECTORS TO THE FACEPLATE

Install the jacks and the external power connector to the faceplate by inserting them from the back side and tightening the knurled nut on the front side. Mount the 2-screw antenna terminal to the faceplate by placing the terminal in front of the faceplate and using the two remaining 4-40 1/4" screws and nuts. Mount the BNC connector by removing the nut and washer, inserting the connector from the front of the panel and tightening the nut over the washer. Refer to the picture on page 21.

4. ATTACH THE PCB TO THE FACEPLATE

Remove the nuts and washers from the standoffs and the nuts from the shafts of the 10k pots. Attach the faceplate to the PCB by fitting the faceplate over the switches and LEDs. Tighten the screws and washers to the standoffs. Tighten the nuts on the 10k pot shafts.

5. SOLDER WIRES TO JACKS AND CONNECTORS

To solder the wire to a jack contact:

1. Insert the wire through the hole in the tab,
2. Press the soldering iron to both the wire and the tab and heat for 5 seconds,
3. Apply the solder to the side away from the soldering iron, making sure that the wire and tab melt the solder, not the iron.

Use the following figure as a guide for wiring connections to the jacks and the external power connector. *See also the photo on the next page.*

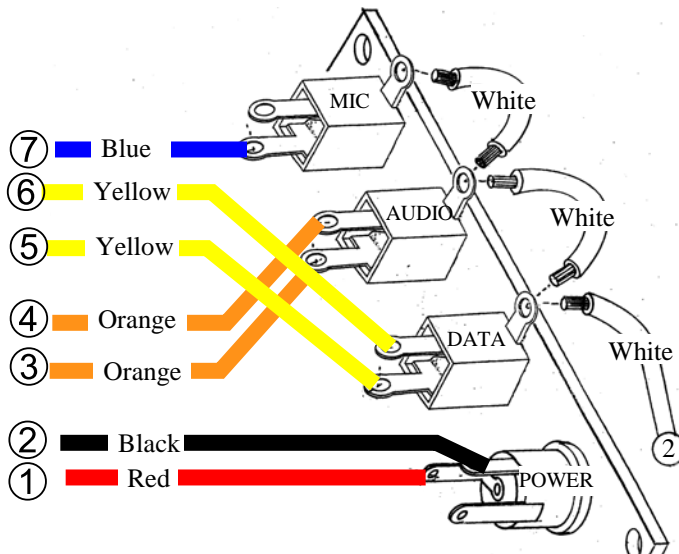

The monaural jack (white body) is the MIC jack. The blue wire connects to this jack.

The center two are the Audio and Data jacks and are the black body stereo type.

The round one is the external power connector.

NOTES:

1. The yellow and orange wires must cross to reach the correct jacks.
2. The white ground wire and the black wire both connect to Location 2.



Close-up showing wires soldered to the jack tabs

NOTE: The orange and yellow wires must cross to connect to the appropriate jacks.

Solder the black "RTN" wire to the RTN side of the antenna terminal.



Insert the red wire into the BNC connector and solder in place.

Solder both red wires to the "ANT+" side of the antenna terminal.

Use the set screws to attach the knobs to the 10k pot shafts.

Install a 9-volt battery in the battery holder.

Use the 4 6/32 1/4 inch screws to attach the faceplate to the enclosure.

THIS COMPLETES THE ASSEMBLY OF YOUR VLF-3 RECEIVER

6. TEST YOUR RECEIVER

Attach an antenna to the ANT+ terminal – a 1-2 meter piece of wire will do.

Attach a ground to the RTN terminal – a short wire that you hold in your hand will do.





6a. Test the audio output

Plug some headphones in the audio output jack.

Turn on the "RECEIVER POWER" switch (main power switch).

Turn on the "AUDIO POWER" switch and slowly turn the "AUDIO LEVEL" up.

You should hear a loud hum as you pick up the 60 hertz signal given off by building wiring.



6b. Test the data output

Connect the "DATA" output jack to the microphone input of an audio recorder using a stereo cable.

Connect headphones to the recorder.

Record the test if you would like.

Turn on the "RECEIVER POWER" switch and slowly turn the "DATA LEVEL" up. You should hear the same signal as you did through the audio output.

Plug a microphone into the MIC IN jack. Slide the switch to the MIC position. You should hear the 60 hertz hum in one ear and the microphone input in the other ear.



6c. Field test your receiver

To ready your receiver for field testing, you will need a better antenna and a better ground. If you need to purchase an antenna, below are links to a few options:

<http://www.amazon.com/Ramsey-WA10-Telescopic-Whip-Antenna/dp/B0002NRLN4>

<http://www.ebay.com/itm/2pcs-Telescopic-Antennas-w-BNC-Connectors-for-Portable-Radio-Scanner-VHF-UHF-/141426792201>

http://www.scannermaster.com/All_Band_Telescoping_Whip_Replacement_Antenna_p/25-541148.htm

A 2-meter length of sturdy wire will work almost as well but is slightly less easy to transport. A good ground is a metal stake or pipe driven into the ground. Attaching a wire from the ground terminal to the stake will provide a good ground. Attaching a wire from the ground terminal to the body of a car (a counterpoise) will work also. In a pinch, you can touch the ground terminal and use your body as a ground.

If you hear a loud squeal as the output, check the output level and the ground connections.

7. Diagnostics Guide – First Steps

So you've read the information above about testing your receiver and you still aren't sure if it is working. If you have never used a Very Low Frequency (VLF) receiver, this is quite understandable. Plug in headphones with the volume all the way down and turn it on. Slowly increase the audio level volume control and listen for a 60 Hz hum. Touch the ANT+ terminal with your finger, zero danger here, to see if the hum significantly increases. If you hear hum, if the hum gets louder when you touch the antenna terminal, then your VLF-3 receiver seems to work. Take it into the field well away from power lines, connect the RTN to the metal of your car or to a solid ground stake, connect the ANT+ to an antenna or connect a whip antenna to the BNC connector, and listen again as you turn up the volume. This time you shouldn't hear hum, but instead crackles and pops, no matter what time of the day or night. If you hear these, then you're in business, your VLF-3 works.

If your receiver squeals when you raise the volume, find a better ground connection and/or look for a source of feedback. If you are listening to an amplified speaker rather than headphones you may have to separate the speaker more from the antenna or use headphones to prevent this feedback.

If your receiver doesn't even provide hum at the output, then something else is going on. It could be a dead battery; it happens, even with new ones sometimes. Or, there could be a problem with the receiver. The following steps are the first suggested for trying to find the problem. If after following these steps you still cannot resolve the problem, then a component might be bad and more complicated testing may be needed. Contact INSPIRE for help if needed.

1. Visually inspect the board looking for solder bridges between connections that should not be there and look for connections that were not soldered. These two errors are far and away the most common. Clean up anything that looks suspicious by removing unnecessary solder. Solder things that need to be soldered. Sometimes a box cutter or other small knife is needed to insure removal of unwanted shorts between printed circuit board traces or solder pads. Of course be careful not to cut anything you didn't set out to cut, like yourself.
2. Double check the wiring to the "data" and "audio" jacks to make sure they are going where they should go. Correct anything miswired.
3. Connect the computer microphone input up to the "data" connector using a stereo 1/8" male to 1/8" male cable. Initially switch "mic/data" down on the VLF-3 to select "data", which should send the VLF signal to both the left and right outputs at the "data connector". Set the computer microphone level input to a modest level, perhaps one-third maximum to start with. Set the receiver "data level" potentiometer fully counterclockwise (lowest level) and then turn the "receiver power" on. Gradually turn up the "data level" in the clockwise direction with your finger touching the "ant" connector. You should hear a strong hum coming out of your computer speakers. If

you hear a hum that increases in volume as you turn up the “data level”, then everything is working up to the point just before the audio amplifier section. If you do not have hum coming to the computer, even at the full “data level” setting, then there is a problem with the frontend of the VLF receiver and you’ll need to perform diagnostics there next.

4. If the computer is being delivered a strong hum, then you should hear that on headphones connected to the “audio out”. I suggest always starting with the volume control (“audio level” in this case) turned all the way down and only increasing it while monitoring the output. If you heard the hum on the computer, but do not hear it in the headphones, then something is wrong with the last amplifier section and you will next need to perform diagnostics there.

5. Nearly all faults will have been corrected by carefully inspecting for solder bridges and missed solder connections. The next most common error is in the wiring from the PCB to the external connections. The previous two steps can help to narrow down where to look for problems after that. Perhaps you’ve missed one of the common errors and by narrowing where you need to look you will find something you’ve missed before. Otherwise diagnostics become a matter of tracing signals through the various components to see if a signal applied to the antenna is getting from one component to the next the way it is supposed to. That can be done with limited test equipment, however a signal generator and oscilloscope make it much easier. But I don’t recommend you go out and buy new test equipment. Contact INSPIRE first. Perhaps the next step is to send it back for repair.

Postscript

Any part shortages or discrepancies should be reported to The INSPIRE Project:
CustomerService@TheINSPIREProject.org

Any corrections, suggestions or recommendations for improvement of the assembly instructions would also be appreciated.

If you would like to submit an article on field observations to The INSPIRE Journal, please email: Editor@TheINSPIREProject.org

Thank you for your participation and support of The INSPIRE Project!