

Low Power 3-1/2 Digit Analog-to-Digital Converter

Features

- Fast Over Range Recovery, Ensured First Reading Accuracy
- Low Temperature Drift Internal Reference
 - TC7136: 70ppm/°C (Typ.)
 - TC7136A: 35ppm/°C (Typ.)
- Zero Reading with Zero Input
- Low Noise: 15μV_{P-P}
- High Resolution: 0.05%
- Low Input Leakage Current: 1pA (Typ.)/10pA (Max.)
- Precision Null Detectors with True Polarity at Zero
- High-Impedance Differential Input
- Convenient 9V Battery Operation with Low Power Dissipation: 500μW (Typ.)/900μW (Max.)

Applications

- Thermometry
- Bridge Readouts: Strain Gauges, Load Cells, Null Detectors
- Digital Meters: Voltage/Current/Ohms/Power, pH
- Digital Scales, Process Monitors
- Portable Instrumentation

Device Selection Table

Part Number	Package	Temperature Range
TC7136 CPI	40-Pin PDIP	0°C to +70°C
TC7136 CKW	44-Pin PQFP	0°C to +70°C
TC7136 CLW	44-Pin PLCC	0°C to +70°C
TC7136A CPI	40-Pin PDIP	0°C to +70°C
TC7136A CKW	44-Pin PQFP	0°C to +70°C
TC7136A CLW	44-Pin PLCC	0°C to +70°C

General Description

The TC7136 and TC7136A are low power, 3-1/2 digit with liquid crystal display (LCD) drivers and analog-to-digital converters. These devices incorporate an "integrator output zero" phase, which enables over range recovery. The performance of existing TC7126, TC7126A and ICL7126 based systems may be upgraded with minor changes to external, passive components.

The TC7136A has an improved internal zener reference voltage circuit which maintains the analog common temperature drift to 35ppm/°C (typical) and 75ppm/°C (maximum). This represents an improvement of two to four times over similar 3-1/2 digit converters. The costly, space consuming external reference source may be removed.

The TC7136 and TC7136A limit linearity error to less than 1 count on 200mV or 2V full scale ranges. The roll-over error (the difference in readings for equal magnitude, but opposite polarity input signals) is below ±1 count. High-impedance differential inputs offer 1pA leakage currents and a 10¹²Ω input impedance. The differential reference input allows ratiometric measurements for ohms or bridge transducer measurements. The 15μV_{P-P} noise performance ensures a "rock solid" reading. The auto-zero cycle enables a zero display readout for a 0V input.

TC7136/TC7136A

Package Type

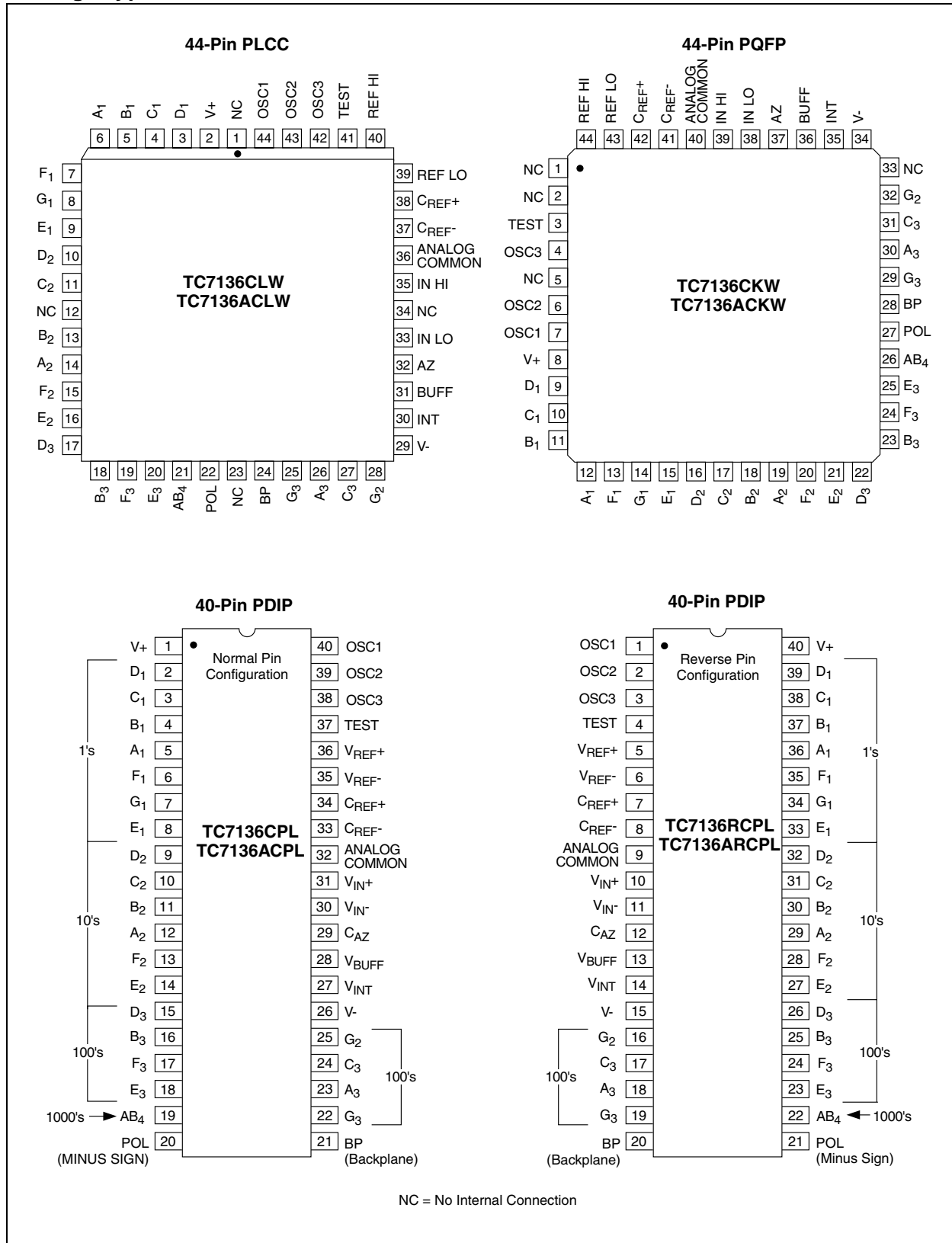

Typical Application

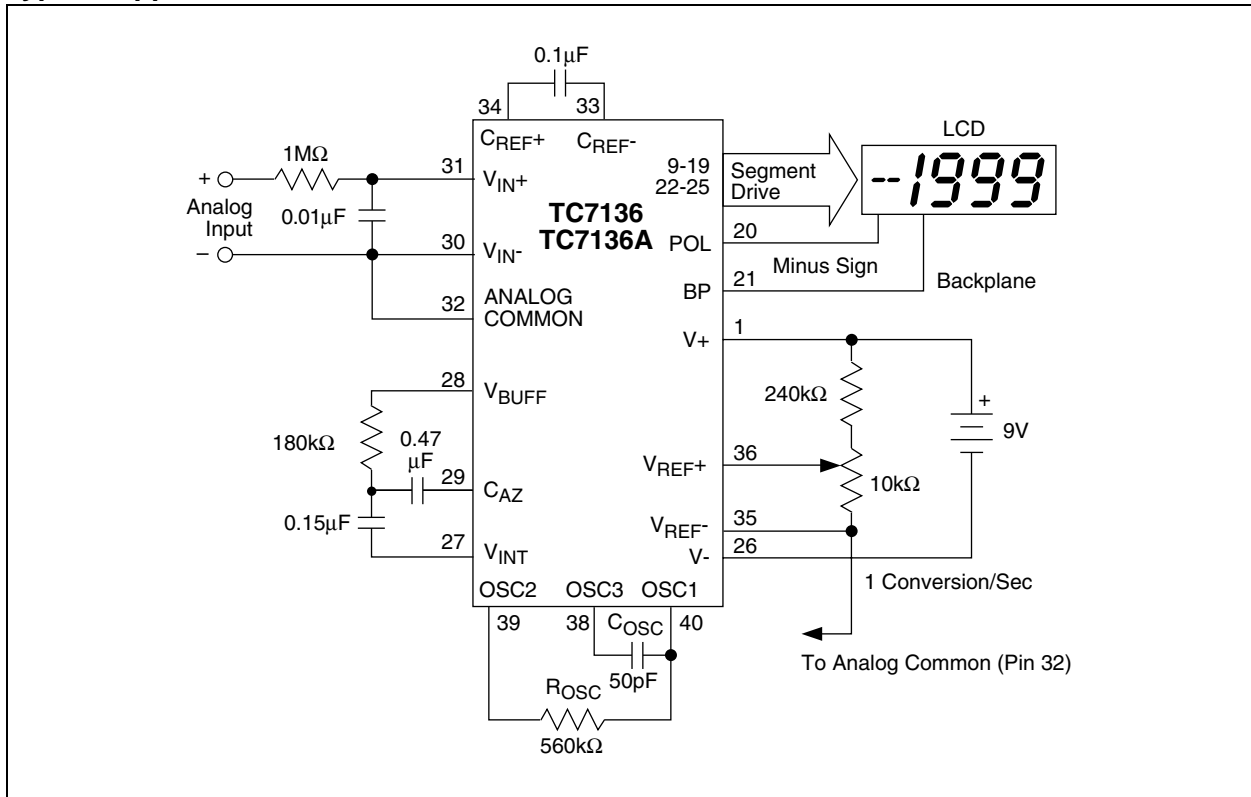

TC7136/TC7136A

Functional Block Diagram

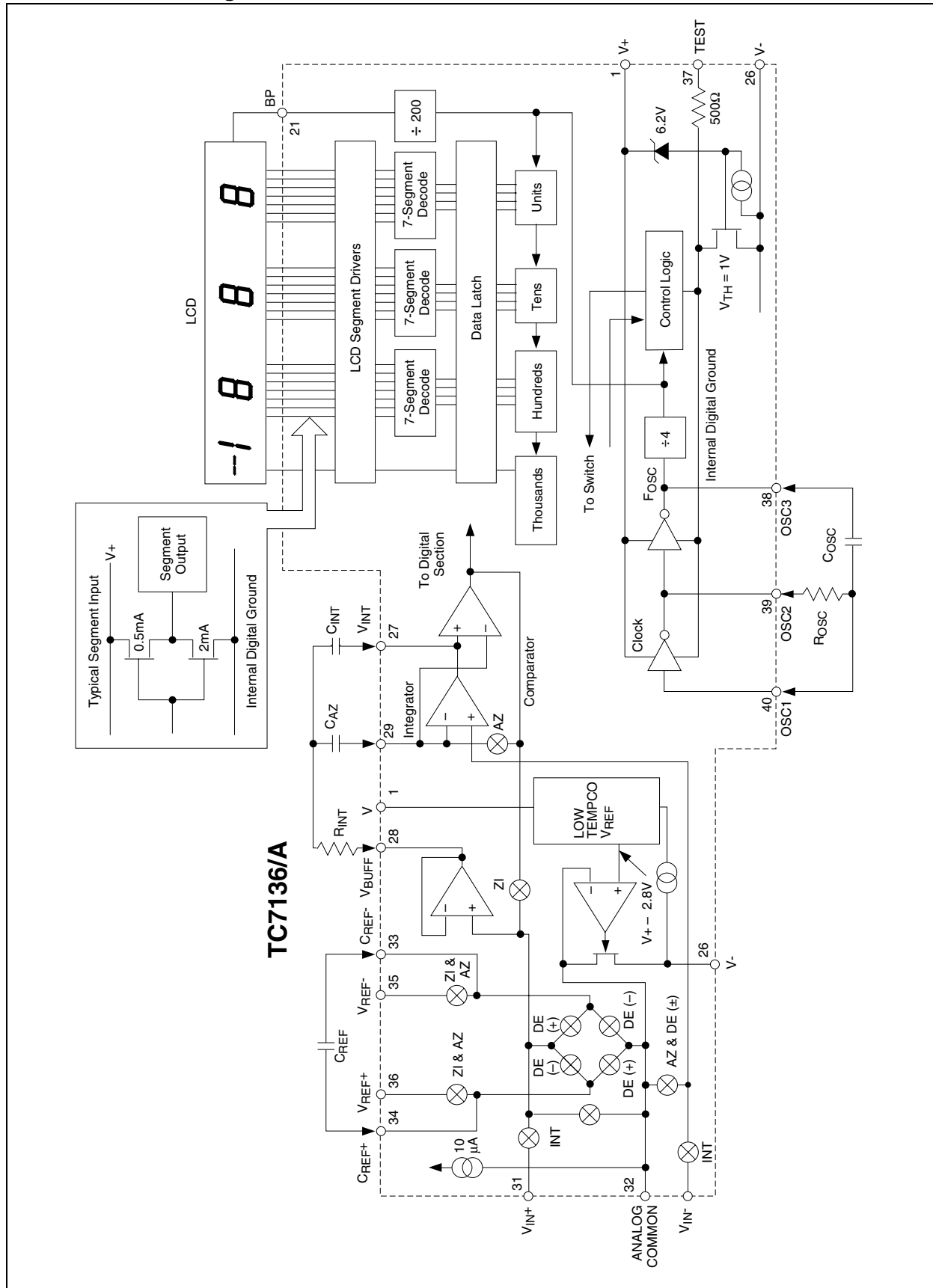

1.0 ELECTRICAL CHARACTERISTICS

Absolute Maximum Ratings*

Supply Voltage (V+ to V-).....	15V
Analog Input Voltage (Either Input) (Note 1)... V+ to V-	
Reference Input Voltage (Either Input).....	V+ to V-
Clock Input	TEST to V+
Package Power Dissipation ($T_A \leq 70^\circ\text{C}$) (Note 2):	
Plastic DIP	1.23W
Plastic Quad Flat Package	1.00W
PLCC	1.23W
Operating Temperature Range:	
C Devices.....	0°C to $+70^\circ\text{C}$
I Devices	-25°C to $+85^\circ\text{C}$
Storage Temperature Range.....	-65°C to $+150^\circ\text{C}$

*Stresses above those listed under "Absolute Maximum Ratings" may cause permanent damage to the device. These are stress ratings only and functional operation of the device at these or any other conditions above those indicated in the operation sections of the specifications is not implied. Exposure to Absolute Maximum Rating conditions for extended periods may affect device reliability.

TC7136 AND TC7136A ELECTRICAL SPECIFICATIONS

Electrical Characteristics: $V_S = 9\text{V}$, $f_{\text{CLK}} = 16\text{kHz}$, and $T_A = +25^\circ\text{C}$, unless otherwise noted.						
Symbol	Parameter	Min	Typ	Max	Unit	Test Conditions
Input						
	Zero Input Reading	-000.0	± 000.0	+000.0	Digital Reading	$V_{\text{IN}} = 0\text{V}$, Full Scale = 200mV
	Zero Reading Drift	—	0.2	1	$\mu\text{V}/^\circ\text{C}$	$V_{\text{IN}} = 0\text{V}$, $0^\circ\text{C} \leq T_A \leq +70^\circ\text{C}$
	Ratiometric Reading	999	999/1000	1000	Digital Reading	$V_{\text{IN}} = V_{\text{REF}}$, $V_{\text{REF}} = 100\text{mV}$
NL	Non-Linearity Error	—	1	± 0.2	Count	Full Scale = 20mV or 2V Max. Deviation from best Straight Line
E_R	Rollover Error	-1	-1	± 0.2	1 Count	$V_{\text{IN}^-} = V_{\text{IN}^+} \approx 200\text{mV}$
e_N	Noise	—	15	—	$\mu\text{V}_{\text{P-P}}$	$V_{\text{IN}} = 0\text{V}$, Full Scale = 200mV
I_L	Input Leakage Current	—	1	10	pA	$V_{\text{IN}} = 0\text{V}$
CMRR	Common Mode Rejection Ratio	—	50	—	$\mu\text{V}/\text{V}$	$V_{\text{CM}} = \pm 1\text{V}$, $V_{\text{IN}} = 0\text{V}$, Full Scale = 200mV
TC_{SF}	Scale Factor Temperature Coefficient	—	1	5	ppm/ $^\circ\text{C}$	$V_{\text{IN}} = 199\text{mV}$, $0^\circ\text{C} \leq T_A \leq +70^\circ\text{C}$ Ext. Ref. Temp. Coeff. = 0ppm/ $^\circ\text{C}$

- Note**
- 1: Input voltages may exceed supply voltages when input current is limited to $100\mu\text{A}$.
 - 2: Dissipation rating assumes device is mounted with all leads soldered to PC board.
 - 3: Refer to "Differential Input" discussion.
 - 4: Backplane drive is in phase with segment drive for "OFF" segment and 180° out-of-phase for "ON" segment. Frequency is 20 times conversion rate. Average DC component is less than 50mV.
 - 5: See "Typical Application".
 - 6: A 48kHz oscillator increases current by $20\mu\text{A}$ (typical). Common current not included.

TC7136/TC7136A

TC7136 AND TC7136A ELECTRICAL SPECIFICATIONS (CONTINUED)

Electrical Characteristics: $V_S = 9V$, $f_{CLK} = 16kHz$, and $T_A = +25^\circ C$, unless otherwise noted.						
Symbol	Parameter	Min	Typ	Max	Unit	Test Conditions
Analog Common						
V_{CTC}	Analog Common Temperature Coefficient					250k Ω between Common and V+
	TC7136A	—	35	75	ppm/ $^\circ C$	$0^\circ C \leq T_A \leq +70^\circ C$
	TC7136	—	70	150	ppm/ $^\circ C$	"C" Commercial Temp. Range Devices
	TC7136A	—	35	100	ppm/ $^\circ C$	$-25^\circ C \leq T_A \leq +85^\circ C$
	TC7136	—	70	150	ppm/ $^\circ C$	"I" Industrial Temp. Range Devices
V_C	Analog Common Voltage	2.7	3.05	3.35	V	250k Ω Between Common and V+
LCD Drive						
V_{SD}	LCD Segment Drive Voltage	4	5	6	V_{P-P}	V+ to V- = 9V
V_{BD}	LCD Backplane Drive Voltage	4	5	6	V_{P-P}	V+ to V- = 9V
Power Supply						
I_S	Power Supply Current	—	70	100	μA	$V_{IN} = 0V$, V+ to V- = 9V (Note 6)

- Note**
- 1: Input voltages may exceed supply voltages when input current is limited to 100 μA .
 - 2: Dissipation rating assumes device is mounted with all leads soldered to PC board.
 - 3: Refer to "Differential Input" discussion.
 - 4: Backplane drive is in phase with segment drive for "OFF" segment and 180 $^\circ$ out-of-phase for "ON" segment. Frequency is 20 times conversion rate. Average DC component is less than 50mV.
 - 5: See "Typical Application".
 - 6: A 48kHz oscillator increases current by 20 μA (typical). Common current not included.

2.0 PIN DESCRIPTIONS

The descriptions of the pins are listed in Table 2-1.

TABLE 2-1: PIN DESCRIPTION

Pin Number (40-Pin PDIP) Normal	(Reverse)	Symbol	Description
1	(40)	V+	Positive supply voltage.
2	(39)	D ₁	Activates the D section of the units display.
3	(38)	C ₁	Activates the C section of the units display.
4	(37)	B ₁	Activates the B section of the units display.
5	(36)	A ₁	Activates the A section of the units display.
6	(35)	F ₁	Activates the F section of the units display.
7	(34)	G ₁	Activates the G section of the units display.
8	(33)	E ₁	Activates the E section of the units display.
9	(32)	D ₂	Activates the D section of the tens display.
10	(31)	C ₂	Activates the C section of the tens display.
11	(30)	B ₂	Activates the B section of the tens display.
12	(29)	A ₂	Activates the A section of the tens display.
13	(28)	F ₂	Activates the F section of the tens display.
14	(27)	E ₂	Activates the E section of the tens display.
15	(26)	D ₃	Activates the D section of the hundreds display.
16	(25)	B ₃	Activates the B section of the hundreds display.
17	(24)	F ₃	Activates the F section of the hundreds display.
18	(23)	E ₃	Activates the E section of the hundreds display.
19	(22)	AB ₄	Activates both halves of the 1 in the thousands display.
20	(21)	POL	Activates the negative polarity display.
21	(20)	BP	Backplane drive output.
22	(19)	G ₃	Activates the G section of the hundreds display.
23	(18)	A ₃	Activates the A section of the hundreds display.
24	(17)	C ₃	Activates the C section of the hundreds display.
25	(16)	G ₂	Activates the G section of the tens display.
26	(15)	V-	Negative power supply voltage.
27	(14)	V _{INT}	The integrating capacitor should be selected to give the maximum voltage swing that ensures component tolerance buildup will not allow the integrator output to saturate. When analog common is used as a reference and the conversion rate is 3 readings per second, a 0.047μF capacitor may be used. The capacitor must have a low dielectric constant to prevent rollover errors. See Section 6.3, Integrating Capacitor for additional details.
28	(13)	V _{BUFF}	Integration resistor connection. Use a 180kΩ for a 20mV full scale range and a 1.8MΩ for 2V full scale range.
29	(12)	C _{AZ}	The size of the auto-zero capacitor influences the system noise. Use a 0.47μF capacitor for a 200mV full scale and a 0.1μF capacitor for a 2V full scale. See Section 6.1, Auto-Zero Capacitor for more details.
30	(11)	V _{IN-}	The low input signal is connected to this pin.
31	(10)	V _{IN+}	The high input signal is connected to this pin.
32	(9)	ANALOG COMMON	This pin is primarily used to set the Analog Common mode voltage for battery operation, or in systems where the input signal is referenced to the power supply. See Section 7.3, Analog Common for more details. It also acts as a reference voltage source.
33	(8)	C _{REF-}	See Pin 34.

TC7136/TC7136A

TABLE 2-1: PIN DESCRIPTION (CONTINUED)

Pin Number (40-Pin PDIP) Normal	(Reverse)	Symbol	Description
34	(7)	C _{REF+}	A 0.1 μ F capacitor is used in most applications. If a large Common mode voltage exists (for example, the V _{IN-} pin is not at analog common) and a 200mV scale is used, a 1 μ F capacitor is recommended, which will hold the rollover error to 0.5 count.
35	(6)	V _{REF-}	See Pin 36.
	(5)	V _{REF+}	The analog input required to generate a full scale output (1999 counts). Place 100mV between Pins 35 and 36 for 199.9mV full scale. Place 1V between Pins 35 and 36 for 2V full scale. See Section 6.6, Reference Voltage.
36	(4)	TEST	Lamp test. When pulled HIGH (to V+), all segments will be turned ON and the display should read -1888. It may also be used as a negative supply for externally generated decimal points. See Section 7.4, Test for additional information.
37	(3)	OSC3	See Pin 40.
38	(2)	OSC2	See Pin 40.
39	(1)	OSC1	Pins 40, 39 and 38 make up the oscillator section. For a 48kHz clock (3 readings per second), connect Pin 40 to the junction of a 180k Ω resistor and a 50pF capacitor. The 180k Ω resistor is tied to Pin 39 and the 50pF capacitor is tied to Pin 38.

3.0 DETAILED DESCRIPTION

(All Pin Designations Refer to 40-Pin PDIP.)

3.1 Dual Slope Conversion Principles

The TC7136/A is a dual slope, integrating analog-to-digital converter. An understanding of the dual slope conversion technique will aid in following detailed TC7136/A operational theory.

The conventional dual slope converter measurement cycle has two distinct phases (see Figure 3-1).

1. Input signal integration
2. Reference voltage integration (de-integration)

The input signal being converted is integrated for a fixed time period (t_{SI}), measured by counting clock pulses. An opposite polarity constant reference voltage is then integrated until the integrator output voltage returns to zero. The reference integration time is directly proportional to the input signal (t_{RI}).

In a simple dual slope converter, a complete conversion requires the integrator output to "ramp up" and "ramp down."

A simple mathematical equation relates the input signal, reference voltage, and integration time:

EQUATION 3-1:

$$\frac{1}{RC} \int_0^{t_{SI}} V_{IN}(t) dt = \frac{V_R t_{RI}}{RC}$$

Where:

- V_R = Reference voltage
- t_{SI} = Signal integration time (fixed)
- t_{RI} = Reference voltage integration time (variable)

For a constant V_{IN} :

EQUATION 3-2:

$$V_{IN} = V_R \frac{t_{RI}}{t_{SI}}$$

FIGURE 3-1: BASIC DUAL SLOPE CONVERTER

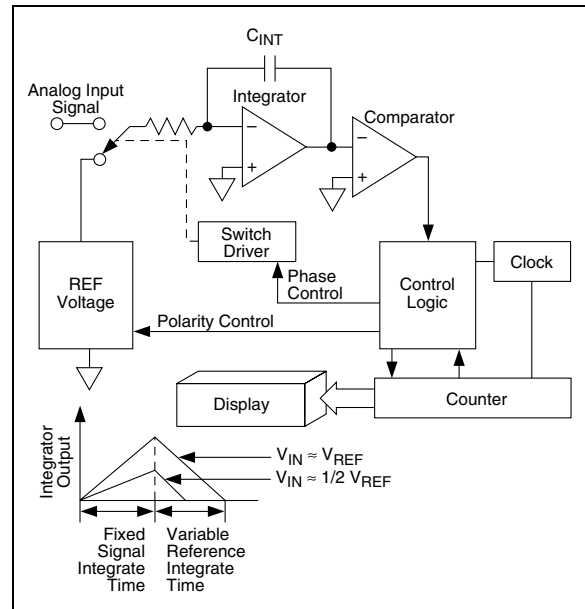
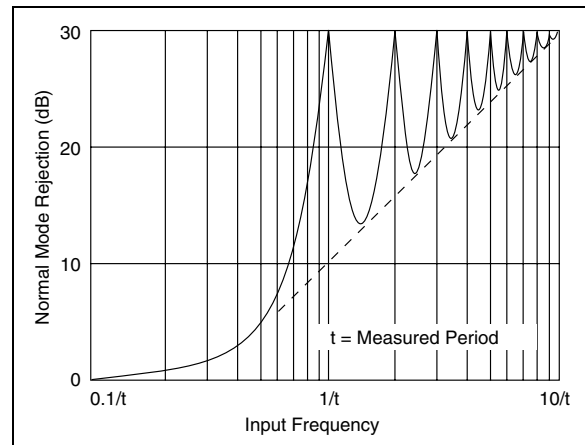

FIGURE 3-2: NORMAL MODE REJECTION OF DUAL SLOPE CONVERTER



The dual slope converter accuracy is unrelated to the integrating resistor and capacitor values, as long as they are stable during a measurement cycle. Noise immunity is an inherent benefit. Noise spikes are integrated or averaged to zero during integration periods. Integrating ADCs are immune to the large conversion errors that plague successive approximation converters in high noise environments. Interfering signals with frequency components at multiples of the averaging period will be attenuated. Integrating ADCs commonly operate with the signal integration period set to a multiple of the 50Hz/60Hz power line period.

TC7136/TC7136A

4.0 ANALOG SECTION

In addition to the basic integrate and de-integrate dual slope cycles discussed above, the TC7136 and TC7136A designs incorporate an "integrator output zero cycle" and an "auto-zero cycle." These additional cycles ensure the integrator starts at 0V (even after a severe over range conversion) and that all offset voltage errors (buffer amplifier, integrator and comparator) are removed from the conversion. A true digital zero reading is assured without any external adjustments.

A complete conversion consists of four distinct phases:

1. Integrator output zero phase
2. Auto-zero phase
3. Signal integrate phase
4. Reference de-integrate phase

4.1 Integrator Output Zero Phase

This phase ensures the integrator output is at 0V before the system zero phase is entered. This ensures that true system offset voltages will be compensated for, even after an over range conversion. The count for this phase is a function of the number of counts required by the de-integrate phase. The count lasts from 11 to 140 counts for non over range conversions and from 31 to 640 counts for over range conversions.

4.2 Auto-Zero Phase

During the auto-zero phase, the differential input signal is disconnected from the circuit by opening internal analog gates. The internal nodes are shorted to analog common (ground) to establish a zero input condition. Additional analog gates close a feedback loop around the integrator and comparator. This loop permits comparator offset voltage error compensation. The voltage level established on C_{AZ} compensates for device offset voltages. The auto-zero phase residual is typically 10 μ V to 15 μ V.

The auto-zero duration is from 910 to 2900 counts for non over range conversions and from 300 to 910 counts for over range conversions.

4.3 Signal Integration Phase

The auto-zero loop is entered and the internal differential inputs connect to V_{IN+} and V_{IN-} . The differential input signal is integrated for a fixed time period. The TC7136/A signal integration period is 1000 clock periods or counts. The externally set clock frequency is divided by four before clocking the internal counters. The integration time period is:

EQUATION 4-1:

$$t_{SI} = \frac{4}{F_{OSC}} \times 1000$$

Where F_{OSC} = external clock frequency.

The differential input voltage must be within the device Common mode range when the converter and measured system share the same power supply common (ground). If the converter and measured system do not share the same power supply common, V_{IN-} should be tied to analog common.

Polarity is determined at the end of signal integrate phase. The sign bit is a true polarity indication, in that signals less than 1LSB are correctly determined. This allows precision null detection, limited only by device noise and auto-zero residual offsets.

4.4 Reference Integrate Phase

The third phase is reference integrate or de-integrate. V_{IN-} is internally connected to analog common and V_{IN+} is connected across the previously charged reference capacitor. Circuitry within the chip ensures that the capacitor will be connected with the correct polarity to cause the integrator output to return to zero. The time required for the output to return to zero is proportional to the input signal and is between 0 and 2000 internal clock periods. The digital reading displayed is:

EQUATION 4-2:

$$1000 = \frac{V_{IN}}{V_{REF}}$$

FIGURE 4-1: CONVERSION TIMING DURING NORMAL OPERATION

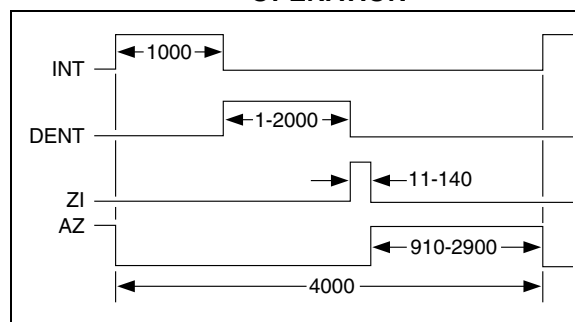
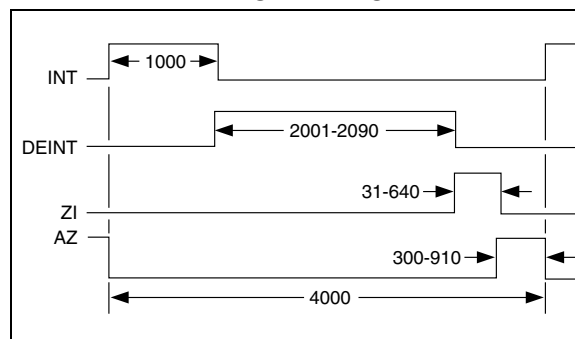

FIGURE 4-2: CONVERSION TIMING DURING OVER RANGE OPERATION



5.0 DIGITAL SECTION

The TC7136/A contains all the segment drivers necessary to directly drive a 3-1/2 digit LCD. An LCD backplane driver is included. The backplane frequency is the external clock frequency divided by 800. For three conversions per second, the backplane frequency is 60Hz with a 5V nominal amplitude. When a segment driver is in phase with the backplane signal, the segment is OFF. An out-of-phase segment drive signal causes the segment to be ON, or visible. This AC drive configuration results in negligible DC voltage across each LCD segment, ensuring long LCD life. The polarity segment driver is ON for negative analog inputs. If V_{IN+} and V_{IN-} are reversed, this indicator would reverse.

On the TC7136/A, when the TEST pin is pulled to $V+$, all segments are turned ON. The display reads -1888. During this mode, the LCD segments have a constant DC voltage impressed.

Note: Do not leave the display in this mode for more than several minutes. LCDs may be destroyed if operated with DC levels for extended periods.

The display font and segment drive assignment are shown in Figure 5-1.

FIGURE 5-1: DISPLAY FONT AND SEGMENT ASSIGNMENT

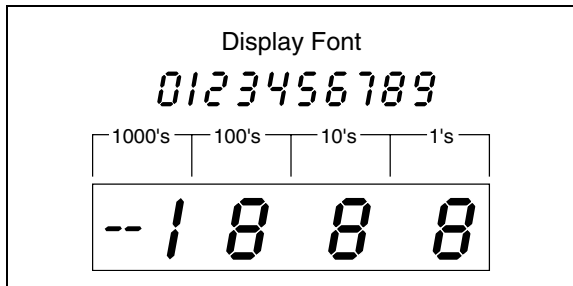

5.1 System Timing

The oscillator frequency is divided by 4 prior to clocking the internal decade counters. The four-phase measurement cycle takes a total of 4000 counts, or 16,000 clock pulses. The 4000 count cycle is independent of input signal magnitude.

Each phase of the measurement cycle has the following length:

1. Auto-zero phase: 3000 to 2900 counts (1200 to 11,600 clock pulses)
2. Signal integrate: 1000 counts (4000 clock pulses)

This time period is fixed. The integration period is:

EQUATION 5-1:

Where:

$$t_{SI} = 4000 \left(\frac{1}{F_{OSC}} \right)$$

F_{OSC} is the externally set clock frequency.

3. Reference integrate: 0 to 2000 counts
4. Zero integrator: 11 to 640 counts

The TC7136 is a drop-in replacement for the TC7126 and ICL7126. The TC7136A offers a greatly improved internal reference temperature coefficient. Minor component value changes are required to upgrade existing designs and improve the noise performance.

6.0 COMPONENT VALUE SELECTION

6.1 Auto-Zero Capacitor (C_{AZ})

The C_{AZ} capacitor size has some influence on system noise. A $0.47\mu\text{F}$ capacitor is recommended for 200mV full scale applications, where 1LSB is $100\mu\text{V}$. A $0.1\mu\text{F}$ capacitor is adequate for 2V full scale applications. A Mylar type dielectric capacitor is adequate.

6.2 Reference Voltage Capacitor (C_{REF})

The reference voltage, used to ramp the integrator output voltage back to zero during the reference integrate phase, is stored on C_{REF} . A $0.1\mu\text{F}$ capacitor is acceptable when V_{REF-} is tied to analog common. If a large Common mode voltage exists ($V_{REF-} \neq$ analog common) and the application requires a 200mV full scale, increase C_{REF} to $1\mu\text{F}$. Rollover error will be held to less than 0.5 count. A Mylar type dielectric capacitor is adequate.

6.3 Integrating Capacitor (C_{INT})

C_{INT} should be selected to maximize integrator output voltage swing without causing output saturation. Analog common will normally supply the differential voltage reference in this case, a $\pm 2\text{V}$ full scale integrator output swing is satisfactory. For 3 readings per second ($F_{OSC} = 48\text{kHz}$), a $0.047\mu\text{F}$ value is suggested. For one reading per second, $0.15\mu\text{F}$ is recommended. If a different oscillator frequency is used, C_{INT} must be changed in inverse proportion to maintain the nominal $\pm 2\text{V}$ integrator swing.

TC7136/TC7136A

An exact expression for C_{INT} is:

EQUATION 6-1:

$$C_{INT} = \frac{(4000) \left(\frac{1}{F_{OSC}} \right) \left(\frac{V_{FS}}{R_{INT}} \right)}{V_{INT}}$$

Where:

- F_{OSC} = Clock frequency at Pin 38
- V_{FS} = Full scale input voltage
- R_{INT} = Integrating resistor
- V_{INT} = Desired full scale integrator output swing

C_{INT} must have low dielectric absorption to minimize rollover error. A polypropylene capacitor is recommended.

6.4 Integrating Resistor (R_{INT})

The input buffer amplifier and integrator are designed with Class A output stages. The output stage idling current is $6\mu A$. The integrator and buffer can supply $1\mu A$ drive currents with negligible linearity errors. R_{INT} is chosen to remain in the output stage linear drive region, but not so large that PC board leakage currents induce errors. For a 200mV full scale, R_{INT} is 180k Ω . A 2V full scale requires 1.8M Ω (see Table 6-1).

TABLE 6-1:

Component Value	Nominal Full Scale Voltage	
	200mV	2V
C_{AZ}	0.47 μF	0.1 μF
R_{INT}	180k Ω	1.8M Ω
C_{INT}	0.047 μF	0.047 μF

Note: $F_{OSC} = 48kHz$ (3 reading per sec).
 $R_{OSC} = 180k\Omega$, $C_{OSC} = 50pF$.

6.5 Oscillator Components

C_{OSC} should be 50pF. R_{OSC} is selected from the equation:

EQUATION 6-2:

$$F_{OSC} = \frac{0.45}{RC}$$

Note that F_{OSC} is $\div 4$ to generate the TC7136A's internal clock. The backplane drive signal is derived by dividing F_{OSC} by 800.

To achieve maximum rejection of 60Hz noise pickup, the signal integrate period should be a multiple of 60Hz. Oscillator frequencies of 240kHz, 120kHz, 80kHz, 60kHz, 40kHz, etc. should be selected. For 50Hz rejection, oscillator frequencies of 200kHz, 100kHz, 66-2/3kHz, 50kHz, 40kHz, etc. would be suitable. Note that 40kHz (2.5 readings per second) will reject both 50Hz and 60Hz.

6.6 Reference Voltage Selection

A full scale reading (2000 counts) requires the input signal be twice the reference voltage.

Required Full Scale Voltage*	V_{REF}
200mV	100mV
2V	1V

Note: $*V_{REF} = 2V_{REF}$.

In some applications, a scale factor other than unity may exist between a transducer output voltage and the required digital reading. Assume, for example, a pressure transducer output for 2000 lb/in² is 400mV. Rather than dividing the input voltage by two, the reference voltage should be set to 200mV. This permits the transducer input to be used directly. The differential reference can also be used when a digital zero reading is required, when V_{IN} is not equal to zero. This is common in temperature measuring instrumentation. A compensating offset voltage can be applied between analog common and V_{IN-} . The transducer output is connected between V_{IN+} and analog common.

7.0 DEVICE PIN FUNCTIONAL DESCRIPTION

7.1 Differential Signal Inputs V_{IN+} (Pin 31), V_{IN-} (Pin 30)

The TC7136/A is designed with true differential inputs and accepts input signals within the input stage Common mode voltage range (V_{CM}). The typical range is

$V+ - 1V$ to $V- + 1V$. Common mode voltages are removed from the system when the TC7136A operates from a battery or floating power source (isolated from measured system). Common mode voltage removed in battery operation with $V_{IN} =$ analog common and V_{IN-} is connected to analog common (V_{COM}) (see Figure 7-1).

FIGURE 7-1: COMMON MODE VOLTAGE REMOVED IN BATTERY OPERATION WITH $V_{IN} =$ ANALOG COMMON

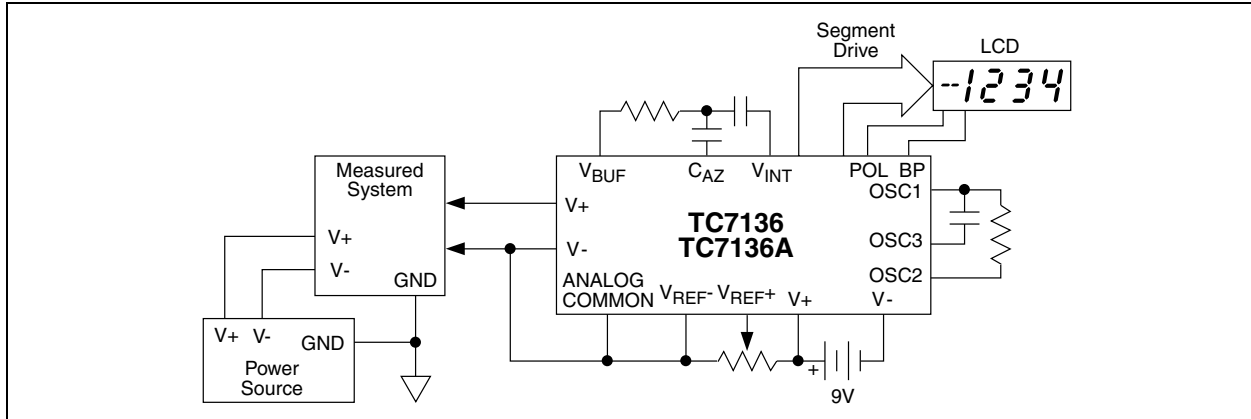

In systems where Common mode voltages exist, the 86dB Common mode rejection ratio minimizes error. Common mode voltages do, however, affect the integrator output level. A worst case condition exists if a large positive V_{CM} exists in conjunction with a full scale negative differential signal. The negative signal drives the integrator output positive along with V_{CM} (see Figure 7-2.) For such applications, the integrator output swing can be reduced below the recommended 2V full scale swing. The integrator output will swing within 0.3V of $V+$ or $V-$ without increased linearity error.

FIGURE 7-2: COMMON MODE VOLTAGE REDUCES AVAILABLE INTEGRATOR SWING ($V_{COM} \neq V_{IN}$)

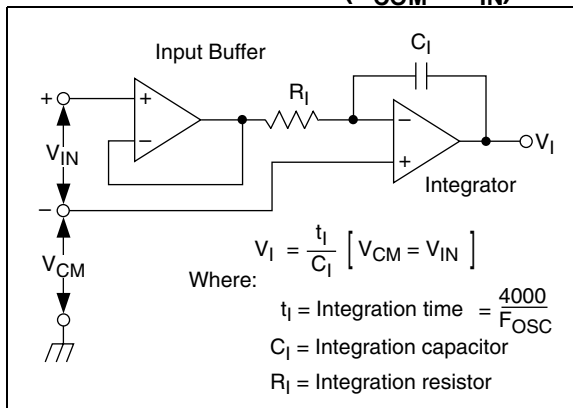

7.2 Differential Reference V_{REF+} (Pin 36), V_{REF-} (Pin 35)

The reference voltage can be generated anywhere within the $V+$ to $V-$ power supply range.

To prevent rollover type errors being induced by large Common mode voltages, C_{REF} should be large compared to stray node capacitance. The TC7136/A offers a significantly improved analog common temperature coefficient. This potential provides a very stable voltage, suitable for use as a voltage reference. The temperature coefficient of analog common is typically 35ppm/°C.

7.3 Analog Common (Pin 32)

The analog common pin is set at a voltage potential approximately 3V below $V+$. The potential is between 2.7V and 3.35V below $V+$. Analog common is tied internally to an N-channel FET, capable of sinking 100 μ A. This FET will hold the common line at 3V below $V+$ if an external load attempts to pull the common line toward $V+$. Analog common source current is limited to 1 μ A. Analog common is, therefore, easily pulled to a more negative voltage (i.e., below $V+ - 3V$).

TC7136/TC7136A

The TC7136/A connects the internal V_{IN+} and V_{IN-} inputs to analog common during the auto-zero phase. During the reference integrate phase, V_{IN-} is connected to analog common. If V_{IN-} is not externally connected to analog common, a Common mode voltage exists, but is rejected by the converter's 86dB Common mode rejection ratio. In battery operation, analog common and V_{IN-} are usually connected, removing Common mode voltage concerns. In systems where V_{IN-} is connected to the power supply ground or to a given voltage, analog common should be connected to V_{IN-} .

The analog common pin serves to set the analog section reference, or common point. The TC7136A is specifically designed to operate from a battery, or in any measurement system where input signals are not referenced (float), with respect to the TC7136A power source. The analog common potential of $V+ - 3V$ gives a 7V end of battery life voltage. The common potential has a 0.001%/°C voltage coefficient.

With sufficiently high total supply voltage ($V+ - V- > 7V$), analog common is a very stable potential with excellent temperature stability (typically 35ppm/°C for TC7136A). This potential can be used to generate the TC7136A's reference voltage. An external voltage reference will be unnecessary in most cases, because of the 35ppm/°C temperature coefficient. See Section 7.5, TC7136A Internal Voltage Reference discussion.

7.4 TEST (Pin 37)

The TEST pin potential is 5V less than $V+$. TEST may be used as the negative power supply connection for external CMOS logic. The TEST pin is tied to the internally generated negative logic supply through a 500Ω resistor. The TEST pin load should not be more than 1mA. See Section 8.0, Typical Applications for additional information on using TEST as a negative digital logic supply.

If TEST is pulled high (to $V+$), all segments plus the minus sign will be activated. DO NOT OPERATE IN THIS MODE FOR MORE THAN SEVERAL MINUTES. With TEST = $V+$, the LCD segments are impressed with a DC voltage which will destroy the LCD.

7.5 TC7136A Internal Voltage Reference

The TC7136 analog common voltage temperature stability has been significantly improved (Figure 7-3). The "A" version of the industry standard TC7136 device allows users to upgrade old systems and design new systems without external voltage references. External R and C values do not need to be changed; however, noise performance will be improved by increasing C_{AZ} (see Section 6.1, Auto-Zero Capacitor). Figure 7-4 shows analog common supplying the necessary voltage reference for the TC7136/A.

FIGURE 7-3: ANALOG COMMON TEMPERATURE COEFFICIENT

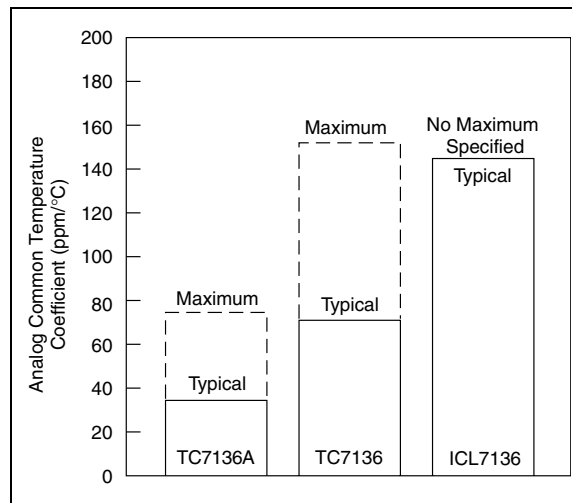
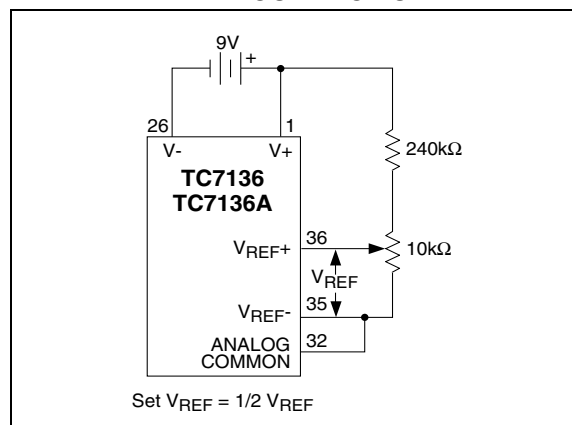

FIGURE 7-4: TC7136A INTERNAL VOLTAGE REFERENCE CONNECTION



8.0 TYPICAL APPLICATIONS

8.1 Liquid Crystal Display Sources

Several manufacturers supply standard LCDs to interface with the TC7136A 3-1/2 digit analog-to-digital converter.

Manufac.	Address/Phone	Representative Part Numbers*
Crystaloid Electronics	5282 Hudson Dr. Hudson, OH 44236 216-655-2429	C5335, H5535, T5135, SX440
AND	720 Palomar Ave. Sunnyvale, CA 94086 408-523-8200	FE 0201, 0501 FE 0203, 0701 FE 2201
VGI, Inc.	1800 Vernon St. Ste.2, Roseville, CA 95678 916-783-7878	I1048, I1126
Hamlin, Inc.	612 E. Lake St. Lake Mills, WI 53551 414-648-236100	3902, 3933, 3903

Note: Contact LCD manufacturer for full product listing/specifications.

8.2 Decimal Point and Annunciator Drive

The TEST pin is connected to the internally generated digital logic supply ground through a 500Ω resistor. The TEST pin may be used as the negative supply for external CMOS gate segment drivers. LCD annunciators for decimal points, low battery indication, or function indication may be added without adding an additional supply. No more than 1mA should be supplied by the TEST pin; its potential is approximately 5V below V+.

8.3 Ratiometric Resistance Measurements

The TC7136A's true differential input and differential reference make ratiometric readings possible. In ratiometric operation, an unknown resistance is measured with respect to a known standard resistance. No accurately defined reference voltage is needed.

The unknown resistance is put in series with a known standard and a current passed through the pair. The voltage developed across the unknown is applied to the input and the voltage across the known resistor applied to the reference input. If the unknown equals the standard, the display will read 1000. The displayed reading can be determined from the following expression:

EQUATION 8-1:

$$\text{Displayed(Reading)} = \frac{R_{\text{UNKNOWN}}}{R_{\text{STANDARD}}} \times 1000$$

The display will over range for:

$$R_{\text{UNKNOWN}} \geq 2 \times R_{\text{STANDARD}}$$

FIGURE 8-1: DECIMAL POINT AND ANNUNCIATOR DRIVES

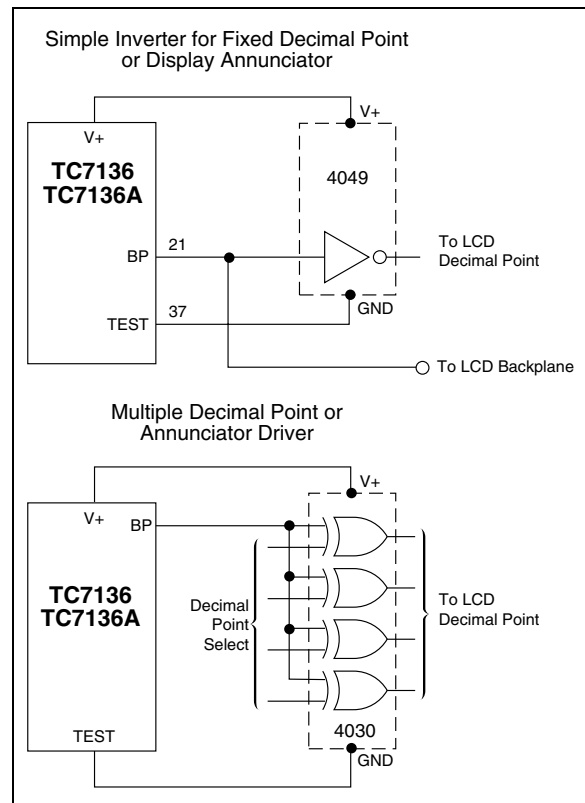

TC7136/TC7136A

FIGURE 8-2: LOW PARTS COUNT RATIO-METRIC RESISTANCE MEASUREMENT

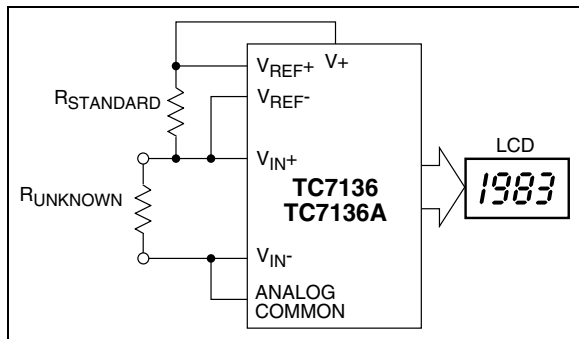

FIGURE 8-3: TEMPERATURE SENSOR

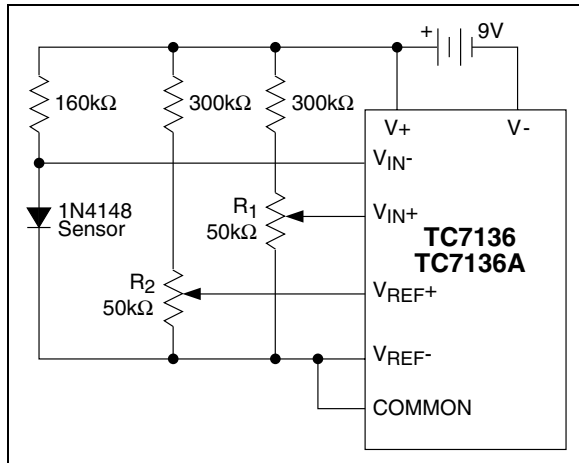
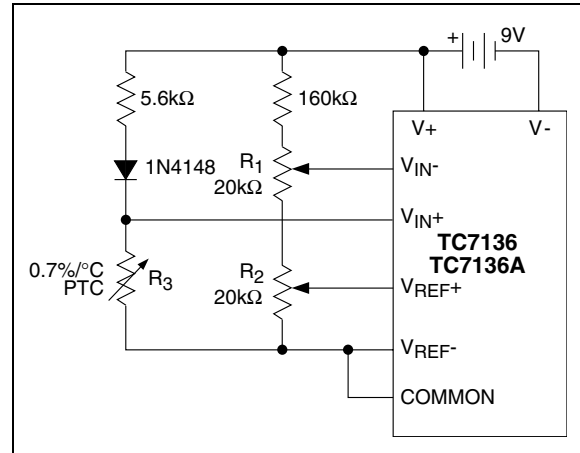

FIGURE 8-4: POSITIVE TEMPERATURE COEFFICIENT RESISTOR TEMPERATURE SENSOR



9.0 PACKAGING INFORMATION

9.1 Package Marking Information

Package marking data not available at this time.

9.2 Taping Form

Component Taping Orientation for 44-Pin PQFP Devices

Standard Reel Component Orientation
for TR Suffix Device

Package	Carrier Width (W)	Pitch (P)	Part Per Full Reel	Reel Size
44-Pin PQFP	24 mm	16 mm	500	13 in

Note: Drawing does not represent total number of pins.

Component Taping Orientation for 44-Pin PLCC Devices

Standard Reel Component Orientation
for TR Suffix Device

Package	Carrier Width (W)	Pitch (P)	Part Per Full Reel	Reel Size
44-Pin PLCC	32 mm	24 mm	500	13 in

Note: Drawing does not represent total number of pins.

TC7136/TC7136A

9.3 Package Dimensions

40-Pin PDIP (Wide)

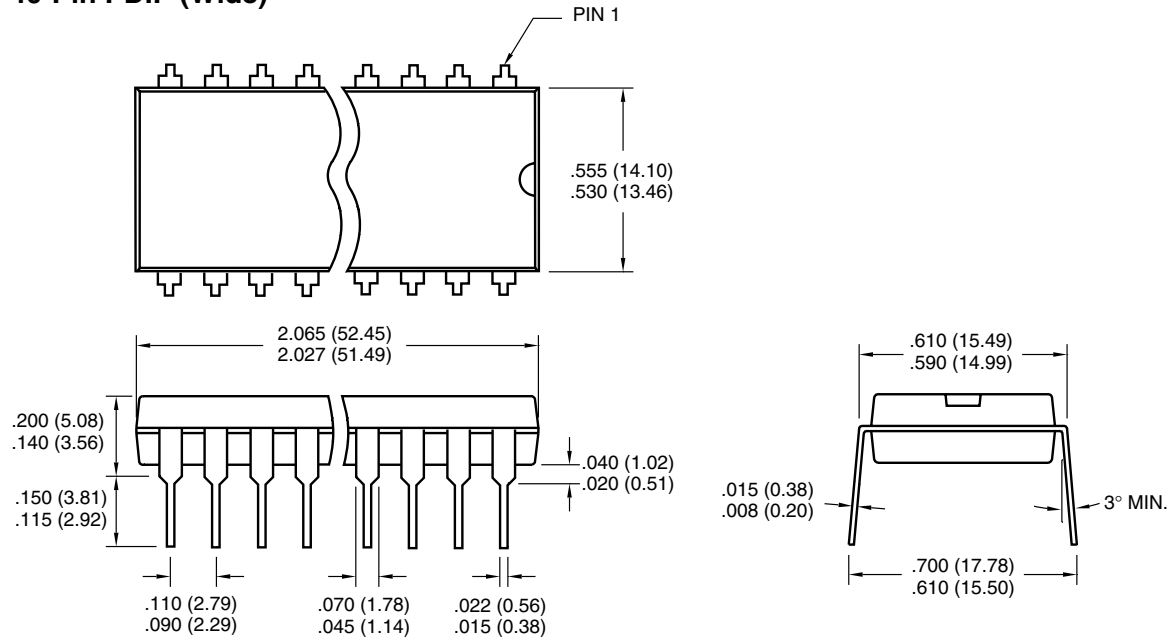

44-Pin PLCC

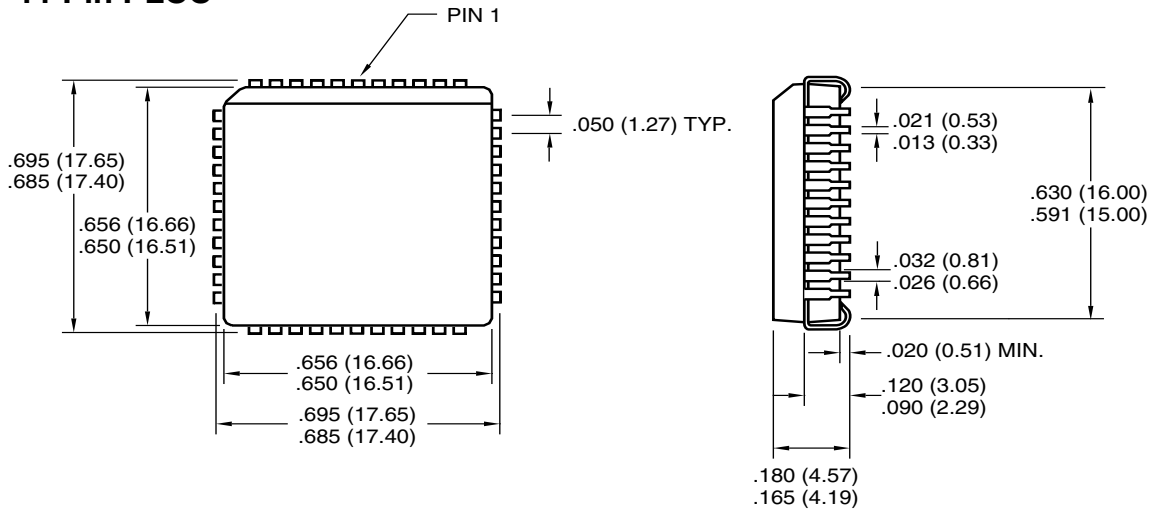

Dimensions: inches (mm)

9.3 Package Dimensions (Continued)

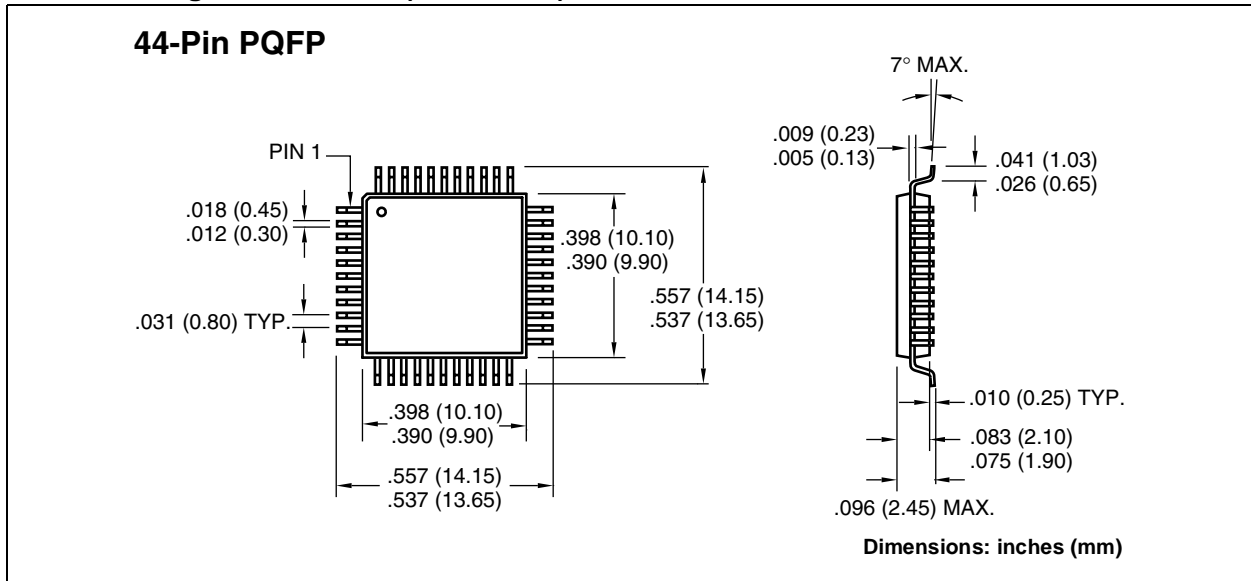

TC7136/TC7136A

SALES AND SUPPORT

Data Sheets

Products supported by a preliminary Data Sheet may have an errata sheet describing minor operational differences and recommended workarounds. To determine if an errata sheet exists for a particular device, please contact one of the following:

1. Your local Microchip sales office
2. The Microchip Corporate Literature Center U.S. FAX: (480) 792-7277
3. The Microchip Worldwide Site (www.microchip.com)

Please specify which device, revision of silicon and Data Sheet (include Literature #) you are using.

New Customer Notification System

Register on our web site (www.microchip.com/cn) to receive the most current information on our products.

Information contained in this publication regarding device applications and the like is intended through suggestion only and may be superseded by updates. It is your responsibility to ensure that your application meets with your specifications. No representation or warranty is given and no liability is assumed by Microchip Technology Incorporated with respect to the accuracy or use of such information, or infringement of patents or other intellectual property rights arising from such use or otherwise. Use of Microchip's products as critical components in life support systems is not authorized except with express written approval by Microchip. No licenses are conveyed, implicitly or otherwise, under any intellectual property rights.

Trademarks

The Microchip name and logo, the Microchip logo, FilterLab, KEELOQ, microID, MPLAB, PIC, PICmicro, PICMASTER, PICSTART, PRO MATE, SEEVAL and The Embedded Control Solutions Company are registered trademarks of Microchip Technology Incorporated in the U.S.A. and other countries.

dsPIC, ECONOMONITOR, FanSense, FlexROM, fuzzyLAB, In-Circuit Serial Programming, ICSP, ICEPIC, microPort, Migratable Memory, MPASM, MPLIB, MPLINK, MPSIM, MXDEV, PICC, PICDEM, PICDEM.net, rfPIC, Select Mode and Total Endurance are trademarks of Microchip Technology Incorporated in the U.S.A.

Serialized Quick Turn Programming (SQTP) is a service mark of Microchip Technology Incorporated in the U.S.A.

All other trademarks mentioned herein are property of their respective companies.

© 2002, Microchip Technology Incorporated, Printed in the U.S.A., All Rights Reserved.

 Printed on recycled paper.



Microchip received QS-9000 quality system certification for its worldwide headquarters, design and wafer fabrication facilities in Chandler and Tempe, Arizona in July 1999 and Mountain View, California in March 2002. The Company's quality system processes and procedures are QS-9000 compliant for its PICmicro® 8-bit MCUs, KEELOQ® code hopping devices, Serial EEPROMs, microperipherals, non-volatile memory and analog products. In addition, Microchip's quality system for the design and manufacture of development systems is ISO 9001 certified.



MICROCHIP

WORLDWIDE SALES AND SERVICE

AMERICAS

Corporate Office

2355 West Chandler Blvd.
Chandler, AZ 85224-6199
Tel: 480-792-7200 Fax: 480-792-7277
Technical Support: 480-792-7627
Web Address: <http://www.microchip.com>

Rocky Mountain

2355 West Chandler Blvd.
Chandler, AZ 85224-6199
Tel: 480-792-7966 Fax: 480-792-7456

Atlanta

500 Sugar Mill Road, Suite 200B
Atlanta, GA 30350
Tel: 770-640-0034 Fax: 770-640-0307

Boston

2 Lan Drive, Suite 120
Westford, MA 01886
Tel: 978-692-3848 Fax: 978-692-3821

Chicago

333 Pierce Road, Suite 180
Itasca, IL 60143
Tel: 630-285-0071 Fax: 630-285-0075

Dallas

4570 Westgrove Drive, Suite 160
Addison, TX 75001
Tel: 972-818-7423 Fax: 972-818-2924

Detroit

Tri-Atria Office Building
32255 Northwestern Highway, Suite 190
Farmington Hills, MI 48334
Tel: 248-538-2250 Fax: 248-538-2260

Kokomo

2767 S. Albright Road
Kokomo, Indiana 46902
Tel: 765-864-8360 Fax: 765-864-8387

Los Angeles

18201 Von Karman, Suite 1090
Irvine, CA 92612
Tel: 949-263-1888 Fax: 949-263-1338

New York

150 Motor Parkway, Suite 202
Hauppauge, NY 11788
Tel: 631-273-5305 Fax: 631-273-5335

San Jose

Microchip Technology Inc.
2107 North First Street, Suite 590
San Jose, CA 95131
Tel: 408-436-7950 Fax: 408-436-7955

Toronto

6285 Northam Drive, Suite 108
Mississauga, Ontario L4V 1X5, Canada
Tel: 905-673-0699 Fax: 905-673-6509

ASIA/PACIFIC

Australia

Microchip Technology Australia Pty Ltd
Suite 22, 41 Rawson Street
Epping 2121, NSW
Australia
Tel: 61-2-9868-6733 Fax: 61-2-9868-6755

China - Beijing

Microchip Technology Consulting (Shanghai)
Co., Ltd., Beijing Liaison Office
Unit 915
Bei Hai Wan Tai Bldg.
No. 6 Chaoyangmen Beidajie
Beijing, 100027, No. China
Tel: 86-10-85282100 Fax: 86-10-85282104

China - Chengdu

Microchip Technology Consulting (Shanghai)
Co., Ltd., Chengdu Liaison Office
Rm. 2401, 24th Floor,
Ming Xing Financial Tower
No. 88 TIDU Street
Chengdu 610016, China
Tel: 86-28-6766200 Fax: 86-28-6766599

China - Fuzhou

Microchip Technology Consulting (Shanghai)
Co., Ltd., Fuzhou Liaison Office
Unit 28F, World Trade Plaza
No. 71 Wusi Road
Fuzhou 350001, China
Tel: 86-591-7503506 Fax: 86-591-7503521

China - Shanghai

Microchip Technology Consulting (Shanghai)
Co., Ltd.
Room 701, Bldg. B
Far East International Plaza
No. 317 Xian Xia Road
Shanghai, 200051
Tel: 86-21-6275-5700 Fax: 86-21-6275-5060

China - Shenzhen

Microchip Technology Consulting (Shanghai)
Co., Ltd., Shenzhen Liaison Office
Rm. 1315, 13/F, Shenzhen Kerry Centre,
Renminnan Lu
Shenzhen 518001, China
Tel: 86-755-2350361 Fax: 86-755-2366086

Hong Kong

Microchip Technology Hongkong Ltd.
Unit 901-6, Tower 2, Metroplaza
223 Hing Fong Road
Kwai Fong, N.T., Hong Kong
Tel: 852-2401-1200 Fax: 852-2401-3431

India

Microchip Technology Inc.
India Liaison Office
Divyasree Chambers
1 Floor, Wing A (A3/A4)
No. 11, O'Shaugnessey Road
Bangalore, 560 025, India
Tel: 91-80-2290061 Fax: 91-80-2290062

Japan

Microchip Technology Japan K.K.
Benex S-1 6F
3-18-20, Shinyokohama
Kohoku-Ku, Yokohama-shi
Kanagawa, 222-0033, Japan
Tel: 81-45-471-6166 Fax: 81-45-471-6122

Korea

Microchip Technology Korea
168-1, Youngbo Bldg. 3 Floor
Samsung-Dong, Kangnam-Ku
Seoul, Korea 135-882
Tel: 82-2-554-7200 Fax: 82-2-558-5934

Singapore

Microchip Technology Singapore Pte Ltd.
200 Middle Road
#07-02 Prime Centre
Singapore, 188980
Tel: 65-6334-8870 Fax: 65-6334-8850

Taiwan

Microchip Technology Taiwan
11F-3, No. 207
Tung Hua North Road
Taipei, 105, Taiwan
Tel: 886-2-2717-7175 Fax: 886-2-2545-0139

EUROPE

Denmark

Microchip Technology Nordic ApS
Regus Business Centre
Lautrup høj 1-3
Ballerup DK-2750 Denmark
Tel: 45 4420 9895 Fax: 45 4420 9910

France

Microchip Technology SARL
Parc d'Activite du Moulin de Massy
43 Rue du Saule Trapu
Batiment A - 1er Etage
91300 Massy, France
Tel: 33-1-69-53-63-20 Fax: 33-1-69-30-90-79

Germany

Microchip Technology GmbH
Gustav-Heinemann Ring 125
D-81739 Munich, Germany
Tel: 49-89-627-144 0 Fax: 49-89-627-144-44

Italy

Microchip Technology SRL
Centro Direzionale Colleoni
Palazzo Taurus 1 V. Le Colleoni 1
20041 Agrate Brianza
Milan, Italy
Tel: 39-039-65791-1 Fax: 39-039-6899883

United Kingdom

Arizona Microchip Technology Ltd.
505 Eskdale Road
Winnersh Triangle
Wokingham
Berkshire, England RG41 5TU
Tel: 44 118 921 5869 Fax: 44-118 921-5820

03/01/02



This datasheet has been downloaded from:

www.DatasheetCatalog.com

Datasheets for electronic components.