

Driver LCA 60W 350–1050mA one4all C PRE OTD premium outdoor series



Product description

- _ Dimmable built-in constant current LED driver
- _ Dimming range 10 to 100 %
- _ Output current adjustable between 350 – 1,050 mA via ready2mains Programmer, I-SELECT 2 plugs or DALI
- _ Max. output power 60 W
- _ Power input on stand-by < 0.16 W
- _ Nominal lifetime up to 100,000 h
- _ 5 years guarantee (Conditions at <https://www.tridonic.com/en/int/services/manufacturer-guarantee-conditions>)

Housing properties

- _ Compact plastic casing
- _ Type of protection IP20

Interfaces

- _ one4all (DALI DT 6, DSI, switchDIM, corridorFUNCTION V2)
- _ ready2mains (configuration and dimming via mains)
- _ U6Me2 (configuration of chronoSTEP 2 via mains)
- _ Terminal blocks: 45° / 0° push terminals

Functions

- _ Adjustable output current in 1-mA-steps (DALI, ready2mains, I-SELECT 2)
- _ Programmable chronoSTEP: times and levels (DALI, U6Me2, ready2mains)
- _ Constant light output function (CLO)
- _ Configurable via ready2mains
- _ Low-temperature start feature (-40 to +70 °C temperature range)
- _ Protective features (overtemperature, short-circuit, overload, no-load, input voltage range, reduced surge amplification)
- _ Suitable for emergency escape lighting systems acc. to EN 50172

Benefits

- _ Application-oriented operating window for maximum compatibility
- _ Best energy savings due to low stand-by losses and high efficiency
- _ Reliability proven by lifetime up to 100,000 h and 5 years guarantee (conditions at <https://www.tridonic.com/en/int/services/manufacturer-guarantee-conditions>)
- _ Flexible configuration via DALI, ready2mains, U6Me2 and I-SELECT 2
- _ In-field programming possible after installation
- _ High overvoltage protection: up to 10 kV asymmetric (protection class I and II)

Typical applications

- _ Road, street and industry
- _ For luminaires of protection class I and protection class II

Website

<http://www.tridonic.com/28001071>



Linear



High bay



Decorative



Downlights



Spotlights



Free-standing



Area



Floor | Wall



Street

Driver LCA 60W 350–1050mA one4all C PRE OTD

premium outdoor series

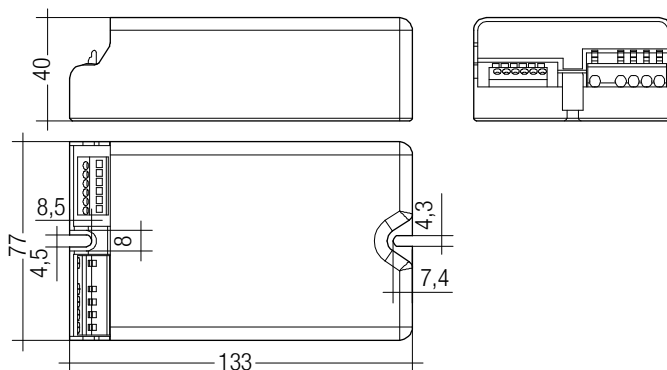
**Ordering data**

Type	Article number [®]	Packaging, carton	Packaging, pallet	Packaging, high volume	Weight per pc.
LCA 60W 350-1050mA one4all C PRE OTD	28001071	10 pc(s).	390 pc(s).	–	0.545 kg
LCA 60W 350-1050mA one4all C PRE OTD	87500663	10 pc(s).	260 pc(s).	1,040 pc(s).	0.557 kg

Technical data

Rated supply voltage	220 – 240 V
AC voltage range	198 – 264 V
DC voltage range	176 – 280 V
Mains frequency	0 / 50 / 60 Hz
Overvoltage protection	320 V AC, 48 h
Typ. current (at 230 V, 50 Hz, full load) ^{①②}	155 – 289 mA
Typ. current (220 V, 0 Hz, full load, 15 % dimming level) ^②	51 – 63 mA
Leakage current (at 230 V, 50 Hz, full load) ^{①②}	< 300 µA
Max. input power	66 W
Typ. efficiency (at 230 V, 50 Hz, full load) ^②	93 %
λ (at 230 V, 50 Hz, full load) ^①	0.99
Typ. power consumption on stand-by ^③	< 0.16 W
In-rush current (peak / duration)	32 A / 267 µs
THD (at 230 V, 50 Hz, full load) ^①	< 7 %
Starting time (at 230 V, 50 Hz, full load) ^①	< 300 ms
Starting time (DC mode)	< 300 ms
Switchover time (AC/DC) ^④	< 150 ms
Turn off time (at 230 V, 50 Hz, full load)	< 20 ms
Output current tolerance ^{①⑤}	± 2 %
Max. output current peak (non-repetitive)	≤ output current + 40 %
Output LF current ripple (< 120 Hz)	± 5 %
Max. output voltage (U-OUT)	120 V
Dimming range	10 – 100 %
Mains surge capability (between L - N) ^⑥	6 kV / 3 kA
Mains surge capability (between L/N - PE)	6 kV
Mains surge capability up to (between L/N - PE) without DALI connection	10 kV
Burst protection ^⑦	6 kV
Surge voltage at output side (against PE)	< 500 V
Type of protection	IP20
Lifetime	up to 100,000 h
Guarantee (conditions at www.tridonic.com)	5 Year(s)
Dimensions L x W x H	133 x 77 x 40 mm

Approval marks**Standards**

EN 55015, EN 61000-3-2, EN 61000-3-3, EN 61000-4-4, EN 61000-4-5, EN 61347-1, EN 61347-2-13, EN 62384, EN 61547, EN 62386-101, EN 62386-102, EN 62386-207 (DALI-2), according to EN 50172, according to EN 60598-2-22

Specific technical data

Type	Output current ^①	Min. output voltage	Max. output voltage	Max. output power	Typ. power consumption (at 230 V, 50 Hz, full load)	Typ. current consumption (at 230 V, 50 Hz, full load)	tc point ^② max.	Ambient temperature ^③ ta	I-SELECT 2 resistor value ^④
LCA 60W 350-1050mA one4all C PRE OTD	350 mA	30 V	85 V	29.8 W	35.0 W	155 mA	80 °C	-40 ... +70 °C	-
LCA 60W 350-1050mA one4all C PRE OTD	400 mA	30 V	85 V	34.0 W	39.3 W	174 mA	80 °C	-40 ... +70 °C	12.50 kΩ
LCA 60W 350-1050mA one4all C PRE OTD	450 mA	30 V	85 V	38.3 W	43.6 W	192 mA	80 °C	-40 ... +70 °C	11.11 kΩ
LCA 60W 350-1050mA one4all C PRE OTD	500 mA	30 V	85 V	42.5 W	47.9 W	211 mA	80 °C	-40 ... +70 °C	10.00 kΩ
LCA 60W 350-1050mA one4all C PRE OTD	550 mA	30 V	85 V	46.8 W	52.3 W	230 mA	85 °C	-40 ... +70 °C	9.09 kΩ
LCA 60W 350-1050mA one4all C PRE OTD	600 mA	30 V	85 V	51.0 W	56.7 W	249 mA	85 °C	-40 ... +70 °C	8.33 kΩ
LCA 60W 350-1050mA one4all C PRE OTD	650 mA	30 V	85 V	55.3 W	61.1 W	267 mA	85 °C	-40 ... +70 °C	7.69 kΩ
LCA 60W 350-1050mA one4all C PRE OTD	700 mA	30 V	85 V	59.5 W	65.7 W	288 mA	85 °C	-40 ... +70 °C	7.14 kΩ
LCA 60W 350-1050mA one4all C PRE OTD	750 mA	30 V	80 V	60.0 W	66.0 W	289 mA	85 °C	-40 ... +70 °C	6.67 kΩ
LCA 60W 350-1050mA one4all C PRE OTD	800 mA	30 V	75 V	60.0 W	65.9 W	288 mA	85 °C	-40 ... +70 °C	6.25 kΩ
LCA 60W 350-1050mA one4all C PRE OTD	850 mA	30 V	71 V	60.0 W	66.0 W	289 mA	85 °C	-40 ... +70 °C	5.88 kΩ
LCA 60W 350-1050mA one4all C PRE OTD	900 mA	30 V	67 V	60.0 W	65.7 W	288 mA	80 °C	-40 ... +70 °C	5.56 kΩ
LCA 60W 350-1050mA one4all C PRE OTD	950 mA	30 V	63 V	60.0 W	65.6 W	287 mA	80 °C	-40 ... +70 °C	5.26 kΩ
LCA 60W 350-1050mA one4all C PRE OTD	1,000 mA	30 V	60 V	60.0 W	65.8 W	288 mA	80 °C	-40 ... +70 °C	5.00 kΩ
LCA 60W 350-1050mA one4all C PRE OTD	1,050 mA	30 V	57 V	60.0 W	66.0 W	289 mA	80 °C	-40 ... +70 °C	4.76 kΩ
LCA 60W 350-1050mA one4all C PRE OTD	350 mA	30 V	85 V	29.8 W	35.0 W	155 mA	80 °C	-40 ... +70 °C	-
LCA 60W 350-1050mA one4all C PRE OTD	400 mA	30 V	85 V	34.0 W	39.3 W	174 mA	80 °C	-40 ... +70 °C	12.50 kΩ
LCA 60W 350-1050mA one4all C PRE OTD	450 mA	30 V	85 V	38.3 W	43.6 W	192 mA	80 °C	-40 ... +70 °C	11.11 kΩ
LCA 60W 350-1050mA one4all C PRE OTD	500 mA	30 V	85 V	42.5 W	47.9 W	211 mA	80 °C	-40 ... +70 °C	10.00 kΩ
LCA 60W 350-1050mA one4all C PRE OTD	550 mA	30 V	85 V	46.8 W	52.3 W	230 mA	85 °C	-40 ... +70 °C	9.09 kΩ
LCA 60W 350-1050mA one4all C PRE OTD	600 mA	30 V	85 V	51.0 W	56.7 W	249 mA	85 °C	-40 ... +70 °C	8.33 kΩ
LCA 60W 350-1050mA one4all C PRE OTD	650 mA	30 V	85 V	55.3 W	61.1 W	267 mA	85 °C	-40 ... +70 °C	7.69 kΩ
LCA 60W 350-1050mA one4all C PRE OTD	700 mA	30 V	85 V	59.5 W	65.7 W	288 mA	85 °C	-40 ... +70 °C	7.14 kΩ
LCA 60W 350-1050mA one4all C PRE OTD	750 mA	30 V	80 V	60.0 W	66.0 W	289 mA	85 °C	-40 ... +70 °C	6.67 kΩ
LCA 60W 350-1050mA one4all C PRE OTD	800 mA	30 V	75 V	60.0 W	65.9 W	288 mA	85 °C	-40 ... +70 °C	6.25 kΩ
LCA 60W 350-1050mA one4all C PRE OTD	850 mA	30 V	71 V	60.0 W	66.0 W	289 mA	85 °C	-40 ... +70 °C	5.88 kΩ
LCA 60W 350-1050mA one4all C PRE OTD	900 mA	30 V	67 V	60.0 W	65.7 W	288 mA	80 °C	-40 ... +70 °C	5.56 kΩ
LCA 60W 350-1050mA one4all C PRE OTD	950 mA	30 V	63 V	60.0 W	65.6 W	287 mA	80 °C	-40 ... +70 °C	5.26 kΩ
LCA 60W 350-1050mA one4all C PRE OTD	1,000 mA	30 V	60 V	60.0 W	65.8 W	288 mA	80 °C	-40 ... +70 °C	5.00 kΩ
LCA 60W 350-1050mA one4all C PRE OTD	1,050 mA	30 V	57 V	60.0 W	66.0 W	289 mA	80 °C	-40 ... +70 °C	4.76 kΩ

① Valid at 100 % dimming level.

② Depending on the selected output current.

③ Depending on the DALI traffic at the interface.

④ Valid for immediate change of power supply type otherwise the starting time is valid.

⑤ Output current is mean value.

⑥ L-N acc. to EN 61000-4-5. 2 Ohm, 1,2/50 μs, 8/20 μs.

⑦ Also applies to corridorFUNCTION.

⑧ Article number 28001071: Made in Europe, article number 87500663: Made in China.

⑨ Not compatible with I-SELECT (generation 1). Calculated resistor value.

I-SELECT 2 PLUG PRE / EXC

Accessory



Product description

- _ Ready-for-use resistor to set output current value
- _ Compatible with LED driver featuring I-select 2 interface; not compatible with I-SELECT (generation 1)
- _ Resistor is base insulated
- _ Resistor power 0.25 W
- _ Current tolerance $\pm 2\%$ additional to output current tolerance
- _ Compatible with LED driver series PRE and EXC

Example of calculation

- _ $R [k\Omega] = 5 V / I_{out} [mA] \times 1000$
- _ E96 resistor value used
- _ Resistor value tolerance $\leq 1\%$; resistor power $\geq 0.1 W$; base insulation necessary
- _ When using a resistor value beyond the specified range, the output current will automatically be set to the minimum value (resistor value too big), respectively to the maximum value (resistor value too small)

Website

<http://www.tridonic.com/28001110>



Ordering data

Type	Article number	Colour	Marking	Current	Resistor value	Packaging, bag	Weight per pc.
I-SELECT 2 PLUG 350MA BL	28001110	Blue	0350 mA	350 mA	14.30 k Ω	10 pc(s).	0.001 kg
I-SELECT 2 PLUG 375MA BL	28001111	Blue	0375 mA	375 mA	13.30 k Ω	10 pc(s).	0.001 kg
I-SELECT 2 PLUG 400MA BL	28001112	Blue	0400 mA	400 mA	12.40 k Ω	10 pc(s).	0.001 kg
I-SELECT 2 PLUG 425MA BL	28001251	Blue	0425 mA	425 mA	11.80 k Ω	10 pc(s).	0.001 kg
I-SELECT 2 PLUG 450MA BL	28001113	Blue	0450 mA	450 mA	11.00 k Ω	10 pc(s).	0.001 kg
I-SELECT 2 PLUG 475MA BL	28001252	Blue	0475 mA	475 mA	10.50 k Ω	10 pc(s).	0.001 kg
I-SELECT 2 PLUG 500MA BL	28001114	Blue	0500 mA	500 mA	10.00 k Ω	10 pc(s).	0.001 kg
I-SELECT 2 PLUG 525MA BL	28001960	Blue	0525 mA	525 mA	9.53 k Ω	10 pc(s).	0.001 kg
I-SELECT 2 PLUG 550MA BL	28001115	Blue	0550 mA	550 mA	9.09 k Ω	10 pc(s).	0.001 kg
I-SELECT 2 PLUG 600MA BL	28001116	Blue	0600 mA	600 mA	8.25 k Ω	10 pc(s).	0.001 kg
I-SELECT 2 PLUG 650MA BL	28001117	Blue	0650 mA	650 mA	7.68 k Ω	10 pc(s).	0.001 kg
I-SELECT 2 PLUG 700MA BL	28001118	Blue	0700 mA	700 mA	7.15 k Ω	10 pc(s).	0.001 kg
I-SELECT 2 PLUG 750MA BL	28001119	Blue	0750 mA	750 mA	6.65 k Ω	10 pc(s).	0.001 kg
I-SELECT 2 PLUG 800MA BL	28001120	Blue	0800 mA	800 mA	6.19 k Ω	10 pc(s).	0.001 kg
I-SELECT 2 PLUG 850MA BL	28001121	Blue	0850 mA	850 mA	5.90 k Ω	10 pc(s).	0.001 kg
I-SELECT 2 PLUG 900MA BL	28001122	Blue	0900 mA	900 mA	5.62 k Ω	10 pc(s).	0.001 kg
I-SELECT 2 PLUG 950MA BL	28001123	Blue	0950 mA	950 mA	5.23 k Ω	10 pc(s).	0.001 kg
I-SELECT 2 PLUG 1000MA BL	28001124	Blue	1000 mA	1,000 mA	4.99 k Ω	10 pc(s).	0.001 kg
I-SELECT 2 PLUG 1050MA BL	28001125	Blue	1050 mA	1,050 mA	4.75 k Ω	10 pc(s).	0.001 kg

1. Standards

EN 55015
 EN 61000-3-2
 EN 61000-3-3
 EN 61000-4-4
 EN 61000-4-5
 EN 61347-1
 EN 61347-2-13
 EN 62384
 EN 61547
 EN 62386-101 (DALI-2)
 EN 62386-102 (DALI-2)
 EN 62386-207 (DALI-2)
 According to EN 50172 for use in central battery systems
 According to EN 60598-2-22 suitable for emergency luminaire

2. Thermal details and life-time

2.1 Expected life-time

Expected life-time								
Type	Output current	ta	40 °C	50 °C	55 °C	60 °C	65 °C	70 °C
LCA 60W 350-1050mA one4all C PRE OTD	350 mA	tc	54 °C	63 °C	67 °C	71 °C	75 °C	80 °C
		Life-time	> 100,000 h	> 100,000 h	> 100,000 h	> 100,000 h	> 100,000 h	75,000 h
	> 350 – 500 mA	tc	56 °C	65 °C	69 °C	73 °C	77 °C	82 °C
		Life-time	> 100,000 h	> 100,000 h	> 100,000 h	> 100,000 h	90,000 h	65,000 h
	> 500 – 705 mA	tc	57 °C	65 °C	70 °C	74 °C	79 °C	83 °C
		Life-time	> 100,000 h	> 100,000 h	> 100,000 h	> 100,000 h	80,000 h	60,000 h
	> 705 – 900 mA	tc	57 °C	66 °C	70 °C	74 °C	78 °C	83 °C
		Life-time	> 100,000 h	> 100,000 h	> 100,000 h	> 100,000 h	80,000 h	60,000 h
	> 900 – 1,000 mA	tc	54 °C	63 °C	67 °C	72 °C	74 °C	80 °C
		Life-time	> 100,000 h	> 100,000 h	> 100,000 h	> 100,000 h	> 100,000 h	60,000 h
	> 1,000 – 1,050 mA	tc	54 °C	63 °C	67 °C	73 °C	76 °C	80 °C
		Life-time	> 100,000 h	> 100,000 h	> 100,000 h	> 100,000 h	90,000 h	65,000 h

The LED Driver is designed for a life-time stated above under reference conditions and with a failure probability of less than 10 %.

The relation of tc to ta temperature depends also on the luminaire design.

If the measured tc temperature is approx. 5 K below tc max., ta temperature should be checked and eventually critical components (e.g. ELCAP) measured. Detailed information on request.

3. Installation / wiring

3.1 Circuit diagram

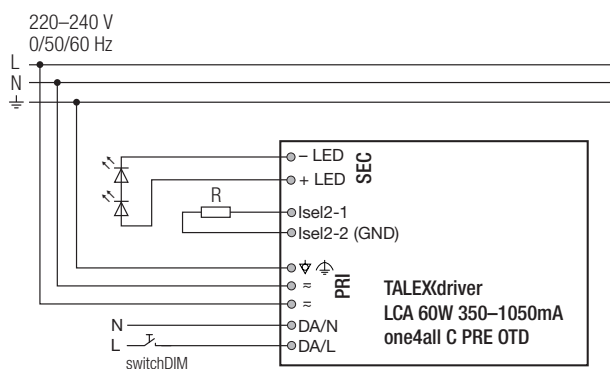
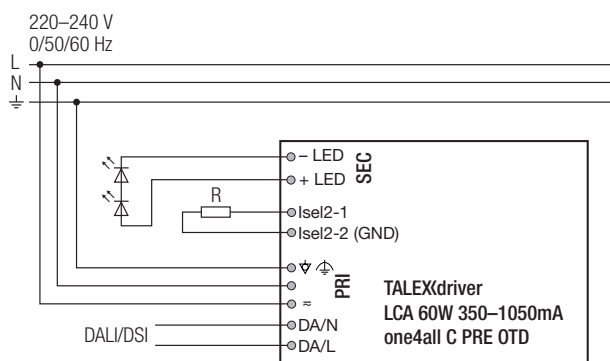

1.1 Glow wire test

according to EN 61347-1 with increased temperature of 750 °C passed.

For wiring in dimming operation with ready2mains refer to the ready2mains Gateway datasheet.

3.2 Wiring type and cross section

Input side:

Solid wire with a cross section of 0.5 – 2.5 mm². Strip 10 – 11 mm of insulation from the cables to ensure perfect operation of terminals.

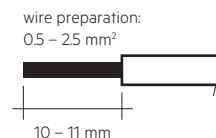

Output side:

Solid wire with a cross section of 0.2 – 1.5 mm². Strip 8.5 – 9.5 mm of insulation from the cables to ensure perfect operation of terminals.

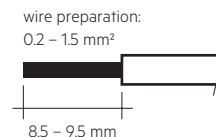

3.3 Wiring guidelines

- The cables should be run separately from the mains connections and mains cables to ensure good EMC conditions.
- The LED wiring should be kept as short as possible to ensure good EMC. The max. secondary cable length is 2 m (4 m circuit), this applies for LED output as well as for I-SELECT 2.
- Secondary switching is not permitted.
- The LED Driver has no inverse-polarity protection on the secondary side. Wrong polarity can damage LED modules with no inverse-polarity protection.
- Wrong wiring of the LED Driver can lead to malfunction or irreparable damage.
- To avoid the damage of the Driver, the wiring must be protected against short circuits to earth (sharp edged metal parts, metal cable clips, louver, etc.).

3.4 Hot plug-in

Hot plug-in is not supported due to residual output voltage of > 0 V. If a LED load is connected, the device has to be restarted before the output will be activated again. This can be done via mains reset or via interface (DALI, DSI, ready2mains).

3.5 Earth connection

The earth connection is conducted as function earth (FE). There is no earth connection required for the functionality of the LED Driver. Earth connection is recommended to improve following behaviour:

- Electromagnetic interferences (EMI)
- LED glowing at standby
- Transmission of mains transients to the LED output

3.6 I-SELECT 2 resistors connected via cable

For details see: http://www.tridonic.com/com/en/download/technical/LCA_PRE_LC_EXC_ProductManual_en.pdf.

3.7 Installation note

Max. torque at the clamping screw: 0.5 Nm / M4

4. Electrical values

4.1 Operating window

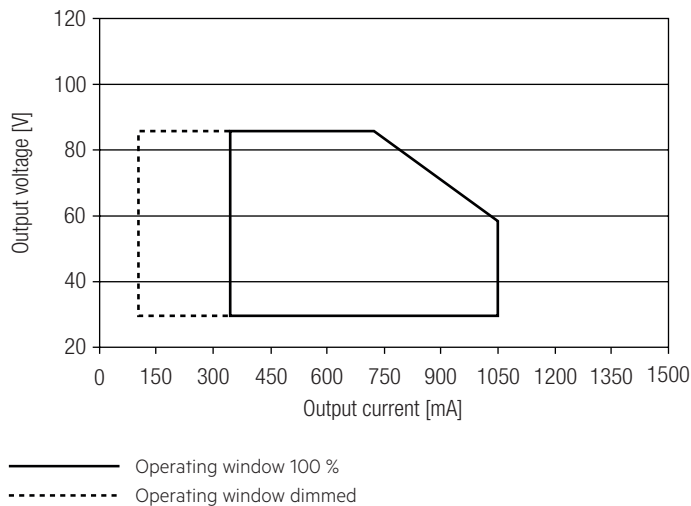

Make sure that the LED Driver is operated within the given window under all operating conditions. Special attention needs to be paid at dimming and DC emergency operation as the forward voltage of the connected LED modules varies with the dimming level, due to the implemented amplitude dimming technology. Coming below the specified minimum output voltage of the LED Driver may cause the device to shut-down. See chapter "6.11 Light level in DC operation" for more information.

4.2 Efficiency vs load

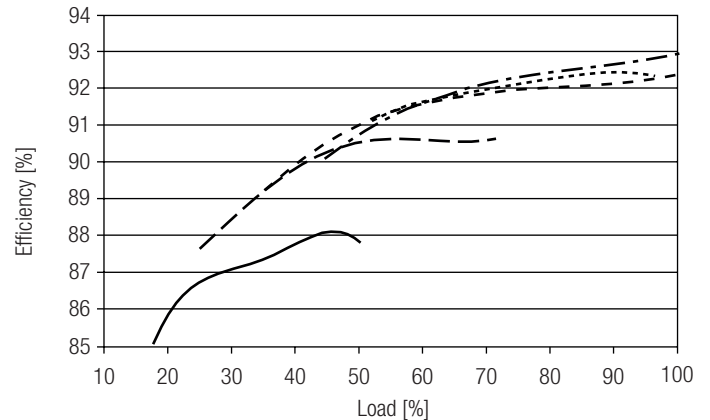

4.3 Power factor vs load

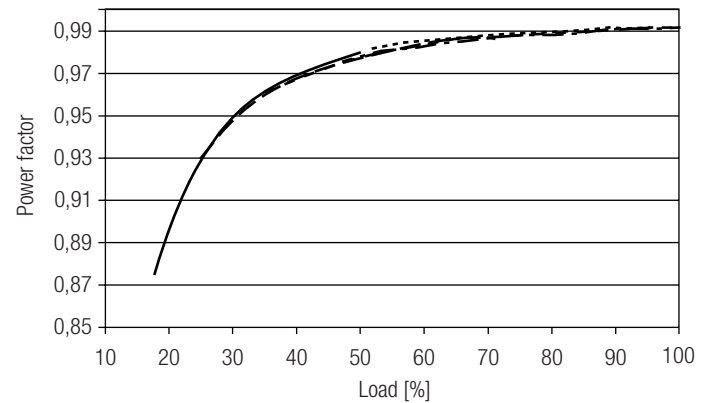

4.4 THD vs load

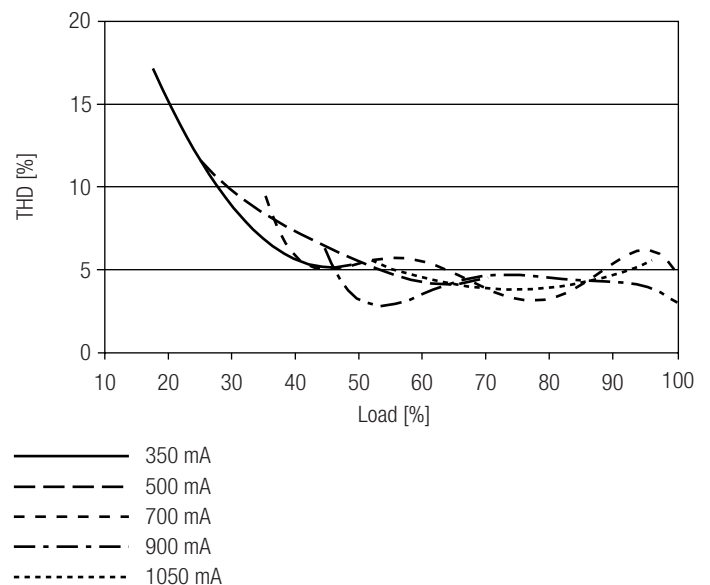

100 % load corresponds to the max. output power (full load) according to the table on page 2.

4.5 Maximum loading of automatic circuit breakers in relation to inrush current

Automatic circuit breaker type	C10	C13	C16	C20	B10	B13	B16	B20	Inrush current	
Installation Ø	1.5 mm ²	1.5 mm ²	2.5 mm ²	4 mm ²	1.5 mm ²	1.5 mm ²	2.5 mm ²	4 mm ²	I _{max}	time
LCA 60W 350-1050mA one4all PRE OTD	11	16	20	25	7	10	12	15	32 A	267 µs

This are max. values calculated out of inrush current! Please consider not to exceed the maximum rated continuous current of the circuit breaker.

Calculation uses typical values from ABB series S200 as a reference.

Actual values may differ due to used circuit breaker types and installation environment.

4.6 Harmonic distortion in the mains supply (at 230 V / 50 Hz and full load) in %

	THD	3.	5.	7.	9.	11.
LCA 60W 350-1050mA one4all C PRE OTD	<7	<8	<4	<2	<1	<2

4.7 Dimming

Dimming range 10% to 100%

Digital control with:

- DSI signal: 8 bit Manchester Code
Speed 10% to 100% in 0.8 s
- DALI signal: 16 bit Manchester Code
Speed 10% to 100% in 0.8 s
Programmable parameter:
Minimum dimming level
Maximum dimming level
Default minimum = 10%
Programmable range 10% ≤ MIN ≤ 100%
Default maximum = 100%
Programmable range 100% ≥ MAX ≥ 10%

Dimming is realized by amplitude dimming.

4.8 Dimming characteristics

Digital dimming value

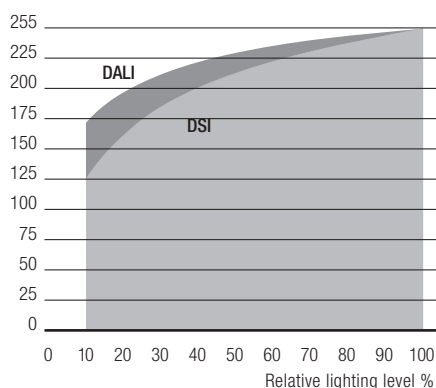

Dimming characteristics as seen by the human eye

5. Interfaces / communication

5.1 Control input (DA/N, DA/L)

Digital DALI signal or corridorFUNCTION can be wired on the same terminals (DA/N and DA/L).

The control input is non-polar for digital control signals (DALI, DSI).

The control signal is not SELV. Control cable has to be installed in

accordance to the requirements of low voltage installations.

Different functions depending on each module.

5.2 Control input ready2mains (L, N)

The digital ready2mains protocol is modulated onto the mains signal which is wired to the mains terminal (L and N).

5.3 switchDIM

Integrated switchDIM function allows a direct connection of a pushbutton for dimming and switching.

Brief push (< 0.6 s) switches LED Driver ON and OFF.

The dimm level is saved at power-down and restored at power-up.

When the pushbutton is held, LED modules are dimmed.

After repush the LED modules are dimmed in the opposite direction.

In installations with LED Drivers with different dimming levels or opposite

dimming directions (e.g. after a system extension), all LED Drivers can be

synchronized to 50% dimming level by a 10 s push.

Use of pushbutton with indicator lamp is not permitted.

5.4 chronoSTEP 2 function (Virtual Midnight)

In the outdoor lighting and street lighting sector it often makes sense to dim the lighting level during night hours in order to save energy.

The chronoSTEP function is a tool that makes this easy to do.

The device automatically measures the switch-on and switch-off times of the lighting installation over the past three days.

The switch-on and switch-off times are typically the times at which the sun

sets and rises. The midpoint of these two reference points is the time

referred to as Virtual Midnight. The overall time interval between switch-on

and switch-off points is called On Time. The Virtual Midnight could be

deactivated with the corresponding plug (28001462).

Notice

When calculating the On-Time, only values between 4 and 24 hours are counted. Values less than 4 hours could indicate a power failure and are therefore not saved. For settings longer than 24 hours, 24 hours is saved as the maximum possible value.

5.5 U6Me2

Settings of chronoSTEP function could be done via switching mains commands.

Detailed description for timings and intervals see product manual.

Key features:

- Auto-dimming with 8 sequences
- Every sequence can hold 8 parameter pairs
- Separate dim-level for each time parameter
- Various commands + parameter for extensions
- Output current setting for each channel individual

6. Functions

6.1 Function: adjustable current

The output current of the LED Driver can be adjusted in a certain range. For adjustment there are three options available.

Option 1: DALI

Adjustment is done by masterCONFIGURATOR (see masterCONFIGURATOR documentation).

Option 2: I-SELECT 2

By inserting a suitable resistor into the I-SELECT 2 interface, the current value can be adjusted. The relationship between output current and resistor value can be found in the chapter "Accessories I-SELECT 2 Plugs".



Please note that the resistor values for I-SELECT 2 are not compatible with I-SELECT (generation 1). Installation of an incorrect resistor may cause irreparable damage to the LED module(s).

Resistors for the main output current values can be ordered from Tridonic (see accessories).

Option 3: ready2mains

Adjustment is done by the ready2mains programmer and the corresponding configuration software (see ready2mains documentation).

The priority for current adjustment methods is DALI (highest priority), I-SELECT 2, ready2mains (lowest priority).

6.2 ready2mains – configuration

The ready2mains interface enables the configuration of the mostly used parameters via the mains wiring.

In the case of PRE LED Driver, the following parameter can be configured via ready2mains, among others:

- LED output current
- optional lockbit
- DC level
- CLO

The configuration is done via the ready2mains Programmer, either directly at the Programmer itself or via a respective software tool. For details on the configuration via ready2mains see the technical information of the Programmer and its tools.

6.3 ready2mains – dimming

The ready2mains interface also allows for mains-based group dimming, without the need for dedicated control wires.

The dimming commands from the control unit are transferred into the digital ready2mains protocol by a ready2mains Gateway. This device then broadcasts the dimming signal to all connected LED drivers via the mains wiring. For details on the dimming functionality via ready2mains see the technical information to ready2mains as well as to the Gateways.

6.4 Short-circuit behaviour

In case of a short-circuit at the LED output the LED output is switched off. After restart of the LED Driver the output will be activated again. The restart can either be done via mains reset or via interface (DALI, DSI, ready2mains).

6.5 No-load operation

The LED Driver will not be damaged in no-load operation. The output will be deactivated and is therefore free of voltage. If a LED load is connected, the device has to be restarted before the output will be activated again.

6.6 Overload protection

If the output voltage range is exceeded, the LED Driver turns off the LED output. After restart of the LED Driver the output will be activated again. The restart can either be done via mains reset or via interface (DALI, DSI, ready2mains).

6.7 Overtemperature protection

The LED Driver is protected against temporary thermal overheating. If the temperature limit is exceeded the output current of the LED module(s) is reduced. The temperature protection is activated above $t_{c\ max}$. The activation temperature differs depending on the LED load. On DC operation this function is deactivated to fulfill emergency requirements.

6.8 corridorFUNCTION V2

The corridorFUNCTION can be programmed in two different ways.

To program the corridorFUNCTION the software and a DALI-USB interface is needed in combination with a DALI PS. The software can be the masterCONFIGURATOR.

To activate the corridorFUNCTION without using software a voltage of 230 V has to be applied at the DA/N and DA/L connection.

The unit will then switch automatically to the corridorFUNCTION.

corridorFUNCTION is a very simple tool for controlling gears with conventional pushbuttons or motion sensors.

To ensure correct operation a sinusoidal mains voltage with a frequency of 50 Hz or 60 Hz is required at the control input.

Special attention must be paid to achieving clear zero crossings.

Serious mains faults may impair the operation of corridorFUNCTION.

Note:

By using corridorFUNCTION V2 programming and monitoring via DALI is always possible.

6.9 Constant light output (CLO)

The luminous flux of a LED decreases constantly over the life-time. The CLO function ensures that the emitted luminous flux remains stable. For that purpose the LED current will increase continuously over the LED life-time. In masterCONFIGURATOR it is possible to select a start value (in percent) and an expected life-time. The LED Driver adjusts the current afterwards automatically.

6.10 Power-up/-down fading

The power-up/-down function offers the opportunity to modify the on-/off behavior. The time for fading on or off can be adjusted in a range of 0.2 to 16 seconds. According to this value, the device dims either from 0 % up to the power-on level or from the current set dim level down to 0 %. This feature applies while operating via ready2mains and when switching the mains voltage on or off. By factory default no fading time is set (= 0 seconds).

6.11 Light level in DC operation

The LED Driver is designed to operate on DC voltage and pulsed DC voltage. For a reliable operation, make sure that also in DC emergency operation the LED Driver is run within the specified conditions as stated in chapter "4.1 operating window".

Light output level in DC operation: programmable 10 – 100 % (EOF_i = 0.13).
Programming by DALI or ready2mains.
In DC operation dimming mode can be activated.

The voltage-dependent input current of Driver incl. LED module is depending on the used load.

The voltage-dependent no-load current of Driver (without or defect LED module) is for:
AC: < 21.5 mA
DC: < 2.2 mA

6.12 Software / programming

With appropriate software and an interface different functions can be activated and various parameters can be configured in the LED Driver. DALI-USB or ready2mains programmer and the software (masterCONFIGURATOR) are required.

6.13 masterCONFIGURATOR

From version 2.8:
For programming functions (CLO, I-SELECT 2, power-up fading, corridorFUNCTION) and device settings (fade time, ePowerOnLevel, DC level, etc.). For further information see masterCONFIGURATOR manual.

6.14 deviceCONFIGURATOR

PC (windows) based software application to transfer parameters into our drivers.
Workflow optimised for the use in OEM production line.
For further information see deviceCONFIGURATOR manual.

7. Miscellaneous

7.1 Insulation and electric strength testing of luminaires

Electronic devices can be damaged by high voltage. This has to be considered during the routine testing of the luminaires in production.

According to IEC 60598-1 Annex Q (informative only!) or ENEC 303-Annex A, each luminaire should be submitted to an insulation test with 500 V_{DC} for 1 second. This test voltage should be connected between the interconnected phase and neutral terminals and the earth terminal.
The insulation resistance must be at least 2 MΩ.

As an alternative, IEC 60598-1 Annex Q describes a test of the electrical strength with 1500 V_{AC} (or 1.414 x 1500 V_{DC}). To avoid damage to the electronic devices this test must not be conducted.

The equipotential terminal is used to connect the heat sink and the LED Driver to reduce transients.

7.2 Conditions of use and storage

Humidity: 5% up to max. 85%,
not condensed
(max. 56 days/year at 85%)

Storage temperature: -40 °C up to max. +80 °C

The devices have to be acclimatised to the specified temperature range (t_a) before they can be operated.

7.3 Maximum number of switching cycles

All LED Driver are tested with 50,000 switching cycles.
The actually achieved number of switching cycles is significantly higher.

7.4 Additional information

Additional technical information at www.tridonic.com → Technical Data

Guarantee conditions at www.tridonic.com → Services

Life-time declarations are informative and represent no warranty claim.
No warranty if device was opened.