



Personal Scope HPS10 Technical Doc



IN THE PACKAGE:



**HPS10 unit
User Manual
PROBE60S**



**OPTIONAL :
CASEHPS, hard case**



BAGHPS, special bag for HPS10 / HPS40



**GIB, general instruments bag (soft)
PS905, 9Vdc/500mA adaptor**



A division of Velleman Components

SAMPLE FOR APPROVAL**Model type** : HPS10**Description** : Hand Held Personal Scope**Sample number:****Customer** :**Remarks / modifications to previous sample:****Includes:**HPS10 unit
Manual and documents
Safety measuring probe (PROBE60S)**Prepared by:****Approved by:****Customer acceptance by:**
Please return signed copy**DATE :****DATE :****DATE :**

Declaration of Conformity



We, Manufacturer

**Velleman Components
Legen Heirweg 33
9890 Gavere
Belgium**

declare that the product

HPS10 Personal Scope

if used according the instructions included with the unit meet the directives
in accordance with 89/336/EEC-EMC Directive
and

EN 55022 Limits and methods of measurement of radio interference characteristics of informa-
tion technology equipment (CISPR22 limits)

EN 50082-1 Electromagnetic Compatibility - Generic immunity standard

IEC 1010-1 Safety requirements for equipment for measurement, control and laboratory use (*)
(*) if equipment used with safety measurement probe

FCC Part 15 Part B Unintentional radiators

For the manufacturer

Date: 03/05/2002

Signature:  _____

Name: Stephan Santens
R&D manager

VELLEMAN Instruments

Start frequency: 30MHZ

HPS10 1 CH Personal Scope

End frequency: 1GHz

EN55022 Field strenght

30dB Probe correction attenuation

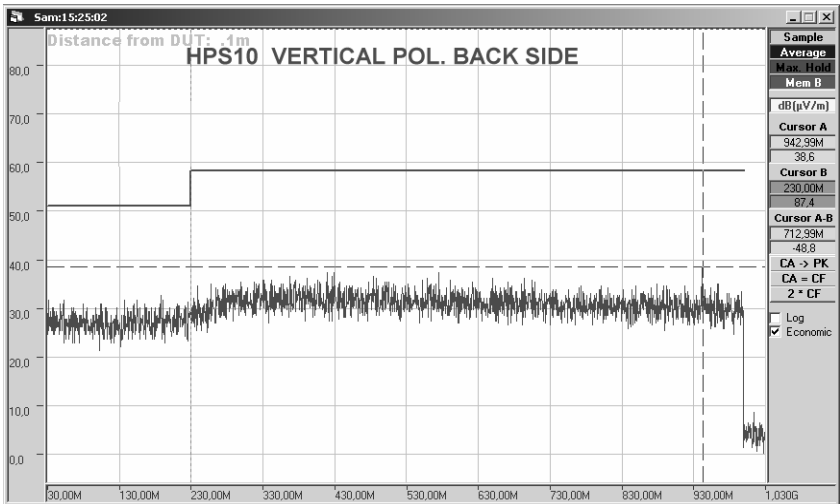
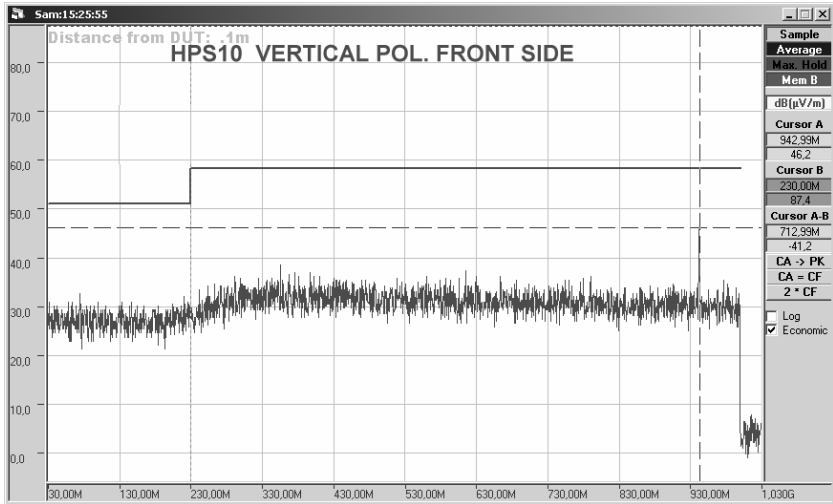

VELLEMAN Instruments

Start frequency: 30MHZ

HPS10 1 CH Personal Scope

End frequency: 1GHz

EN55022 Field strenght

30dB Probe correction attenuation

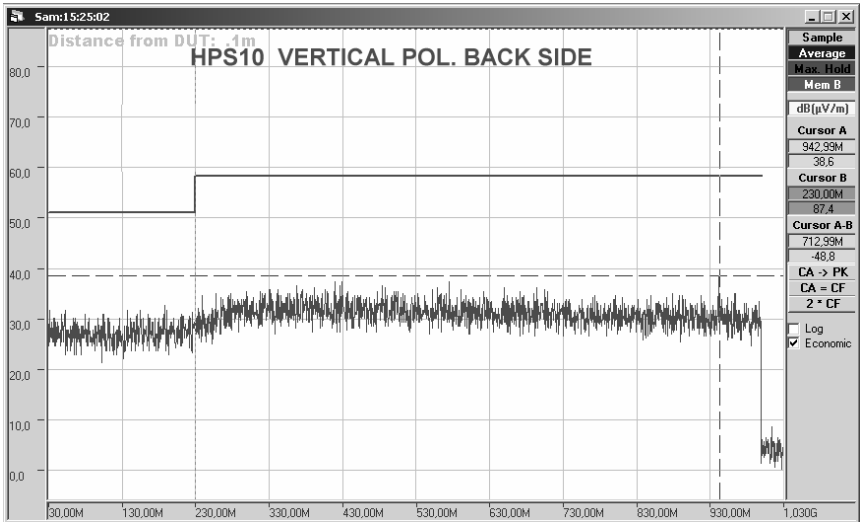
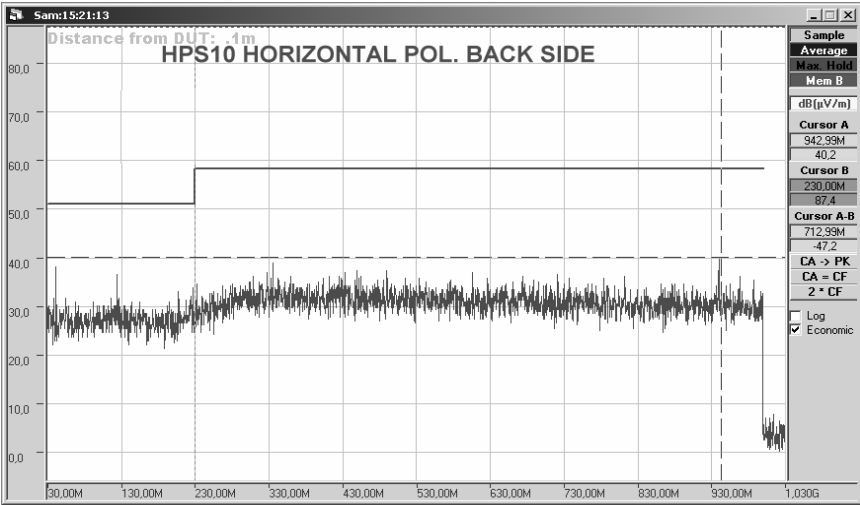

HPS10 BOM

Value/part nr	Description + remark	Part
PHPS5'2	PCB for personal scope	PCB
100µ / 25V	radial elco (max 12mm high !)	C1, C2, C3, C4, C5, C20, C22, C23, C24, C25, C26,
100n	capacitor	C6, C7, C8, C9, C10, C11, C12, C13, C14, C15, C16, C17, C18, C19
4µ7	tantalum capacitor	C21
470n	capacitor	C31, C32, C33, C34
47n / 200V	capacitor 200Vmin !	C35
330p	capacitor	C36
10n	capacitor	C37
1n5 / 200V	capacitor 200Vmin !	C38
18p	capacitor	C39
22p	capacitor	C41, C42
27p	capacitor NEW	C40, C43
47p	capacitor	C30
20p	trim capacitor min 100V	CV1
50p	trim capacitor min 100V	CV2
BAV99	double diode type	D3, D4, D5, D12
BAT54S	double schottky diode	D1, D2
BAS85	Schottky barrier diode	D10, D11
PRLL4001	rectifier diode type	D6, D7, D13
BAS45AL	Low-leakage diode type	D8
BAV70	High speed double diode type	D9
2A	Pico fuse	F1
LM2940S5.0(3)	1A low drop regulator	IC1
MC14052B	analog multiplexer	IC2
MC74HC4052	analog multiplexer MOTOROLA !	IC3 MUST BE MOTOROLA !
OPA604AU	Jfet op amp	IC4
TLC5510INS	8-bit AD converter	IC5
LM311N(8)	Voltage comparator	IC6
VKHPS10	8-Bit CMOS microcontroller	IC7 Programmed microcontroller
LM358M(8)	Low power dual op amp	IC8
220µH	choke	L1, L2, L3, L4
15	resistor	R1
47K	resistor	R5, R6, R9, R10, R12, R13, R60
270K	resistor	R14
10K	resistor	R8, R15, R16, R17, R18, R19, R20, R21, R22,
330	resistor	R2, R3
1K	resistor	R26, R27, R28, R29, R30, R31, R32, R59
22K	resistor	R11, R33, R34
4K7	resistor 1%	R35, R36, R37, R38
100	resistor 1%	R4, R39, R40
39K	resistor 1%	R41
910K	resistor 1%	R42
510	resistor 1%	R43
2K4	resistor 1%	R44, R45
33K	resistor	R46, R47, R48, R49

100K	resistor	R50
47	resistor 1%	R51, R52
180	resistor 1%	R53
27	resistor 1%	R54
560	resistor 1%	R55
750	resistor 1%	R56
4,7	resistor	R57
1M	resistor	R58
100	resistor trimmer 5mm	RV2
500	resistor trimmer 5mm	RV3
47K	resistor trimmer 5mm	RV1, RV4
1FORM A / 5V	Reed Relay 1formA	RY1, RY2, RY3
DJ-005	connector dc jack	SK1
BATCON	battery connector	SK2
BDP32	PNP medium power transistor	T1
PMBT2222A	NPN switching transistor	T3, T4, T5, T6, T7, T8, T9
PMBTA14	NPN darlington transistor	T10
PMBT2907A	PNP switching transistor	T11, T12, T13
BDP31	NPN medium power transistor	T2
X10	quartz cristal 10MHz	X1
10V / 250mW	zener diode	ZD1
5V6 / 250mW	double zener diode	ZD2, ZD3, ZD4, ZD5, ZD6, ZD7
PLCC44	PLCC socket for processor	IC7
96120205	Header connector female 20P	For LCD connection
HDR1X20	Header connector male 20P	For LCD connection
PG12864	Graphic LCD	LCD1
3mm green	led 3mm green	LD1
		NOT MOUNTED: ZD8, R7
Assembly:		
BHPS10	Enclosure (V-0 ABS) for HPS10, dark green	Enclosure HPS10
BNCCHAS	SK3 mounted on enclosure	bnc connector
Battery clip +	For mounting in battery compartment	
Battery clip -	For mounting in battery compartment	
Battery clip - +	For mounting in battery compartment	
Battery clip + -	For mounting in battery compartment	
KBHPS10	Keyboard GREEN (pantone 5793C & 5815C)	SW1,,, SW17
BUS25FF8	For LCD fixation	8mm M2,5 spacer
SHPS10	Safety, battery, ID, info,,, on back of enclosure	Info sticker on backside
M-6	Plug for I/O hole in enclosure	
Misc:		
CSHPS10	Clamshell for HPS10	
ICSHPS10	Colour inlay for clamshell	
PROBE60SB	PROBE60S only with probe spring hook, NO package	
HHPS10	User manual	

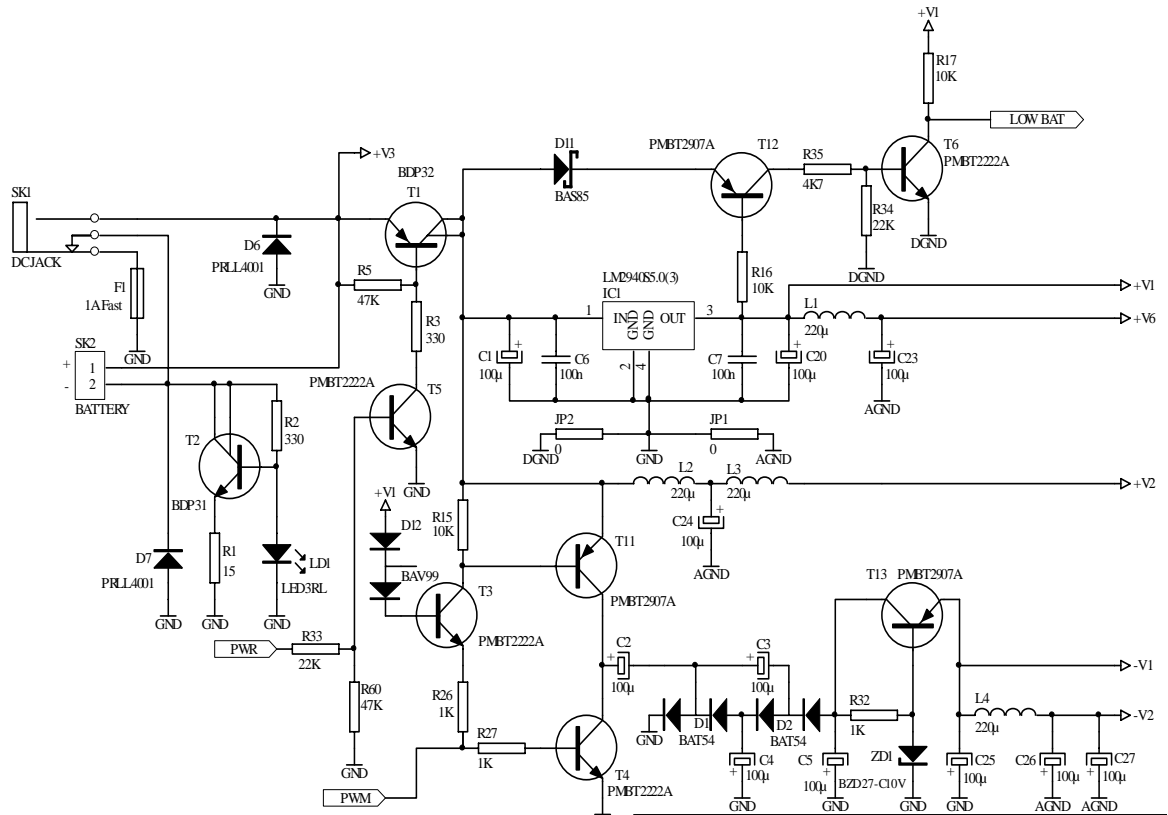

Titel		
PersonalScope: Power Supply Section		
Size	Number	Revision
A4	HPS10	3.0
Date:	19.Nov-2002	Sheet 2 of 4
File:	C:\files\My Documents\In_ontwerp\HPS10\hps10	Drawn By: Eddy De Coelier

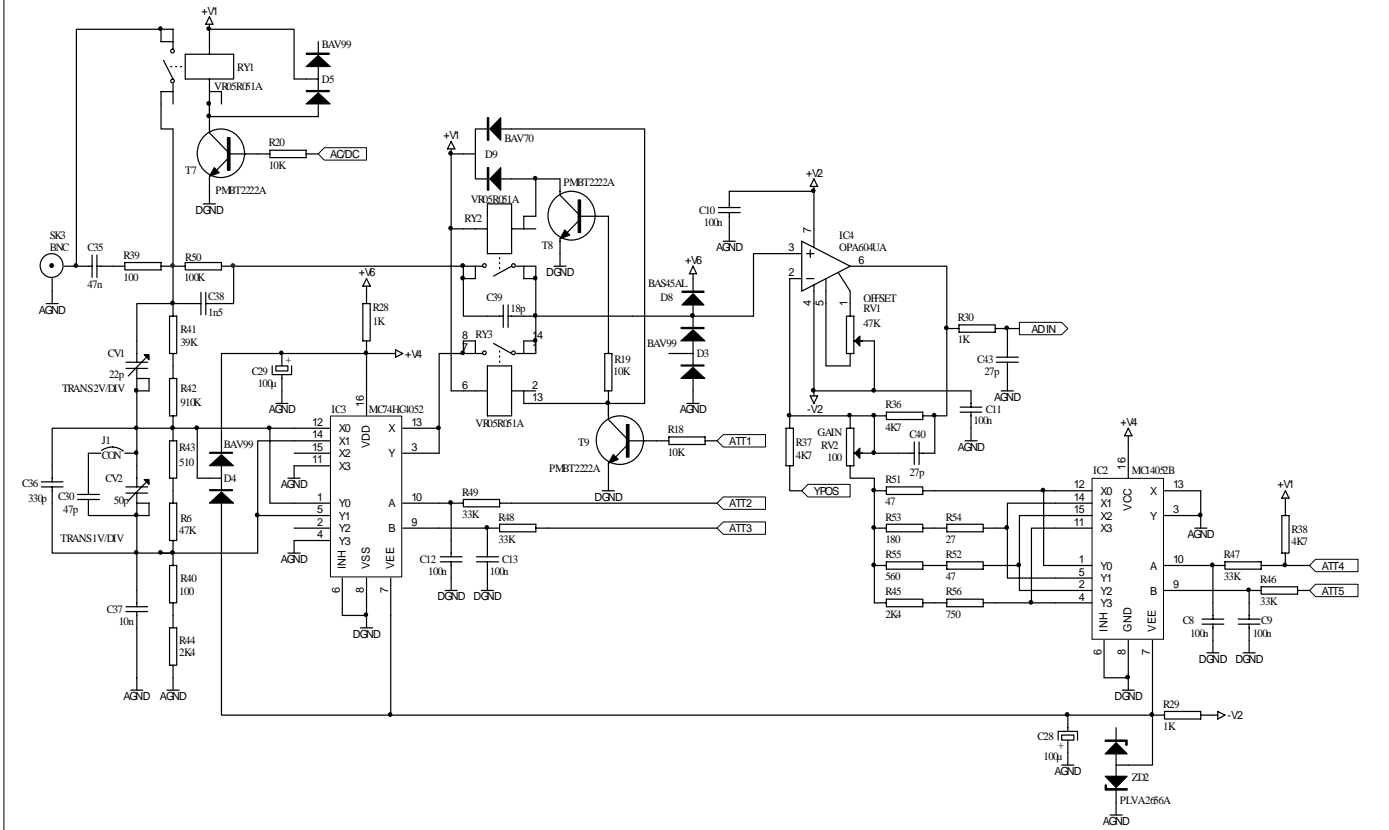

Title			
Personal Scope: Analog section			
Size	Number	Revision	
A4	HPS10	3.0	
Date:	19Nov.2002	Sheet	3d 4
File:	C:\Files\My Documents\sh_order\HPS10\hps10\Drawn By:	Edw:	De Cocker

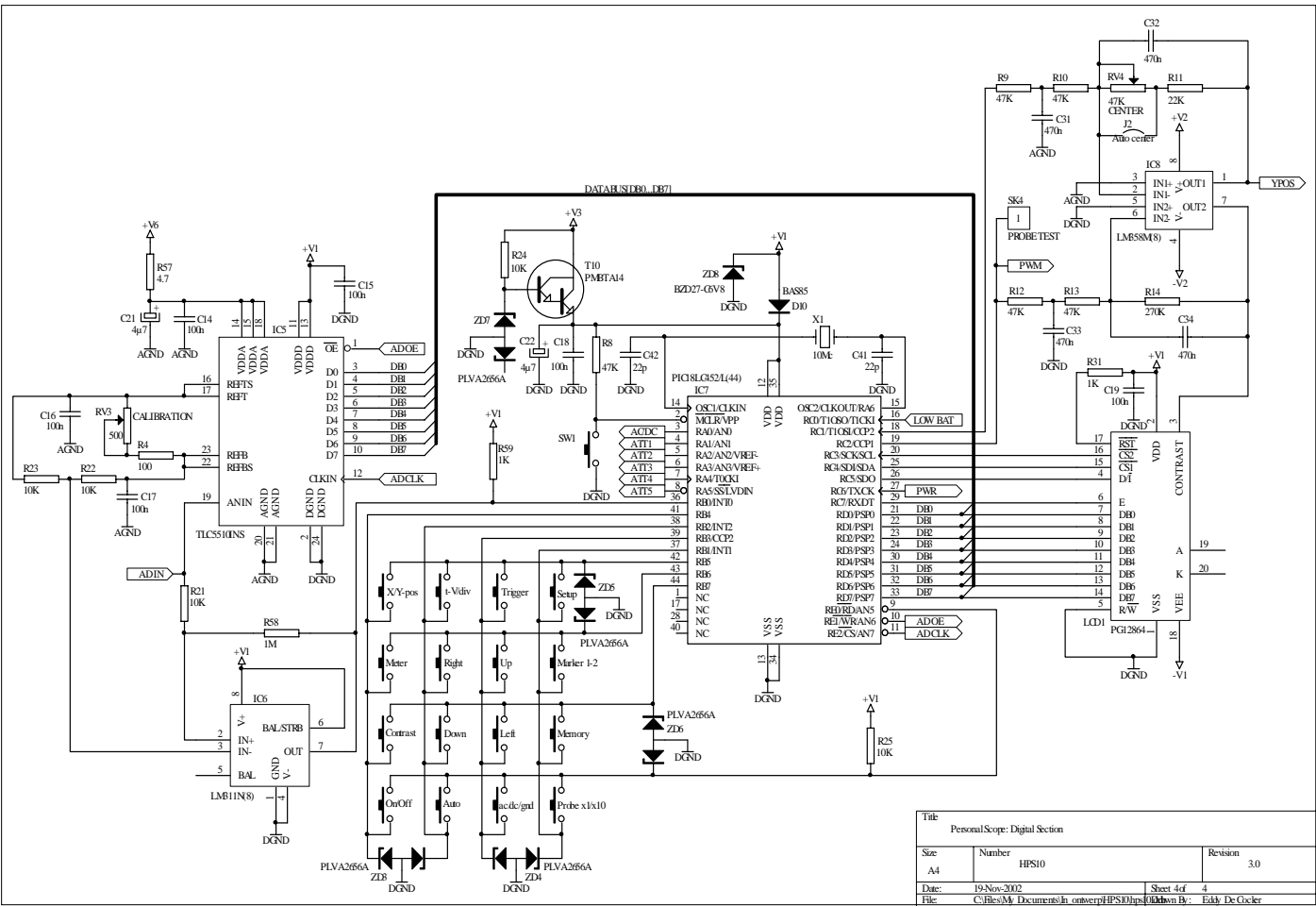

Title			
Personal Score: Digital Section			
Size	Number	HPS10	Revision
A4			3.0
Date:	19-Nov-2002		Sheet 4 of 4
File:	C:\files\Mk_Documents\h_onwerp\HPS10\hps10.dtb\hps10.dtb - Eddy De Clecker		

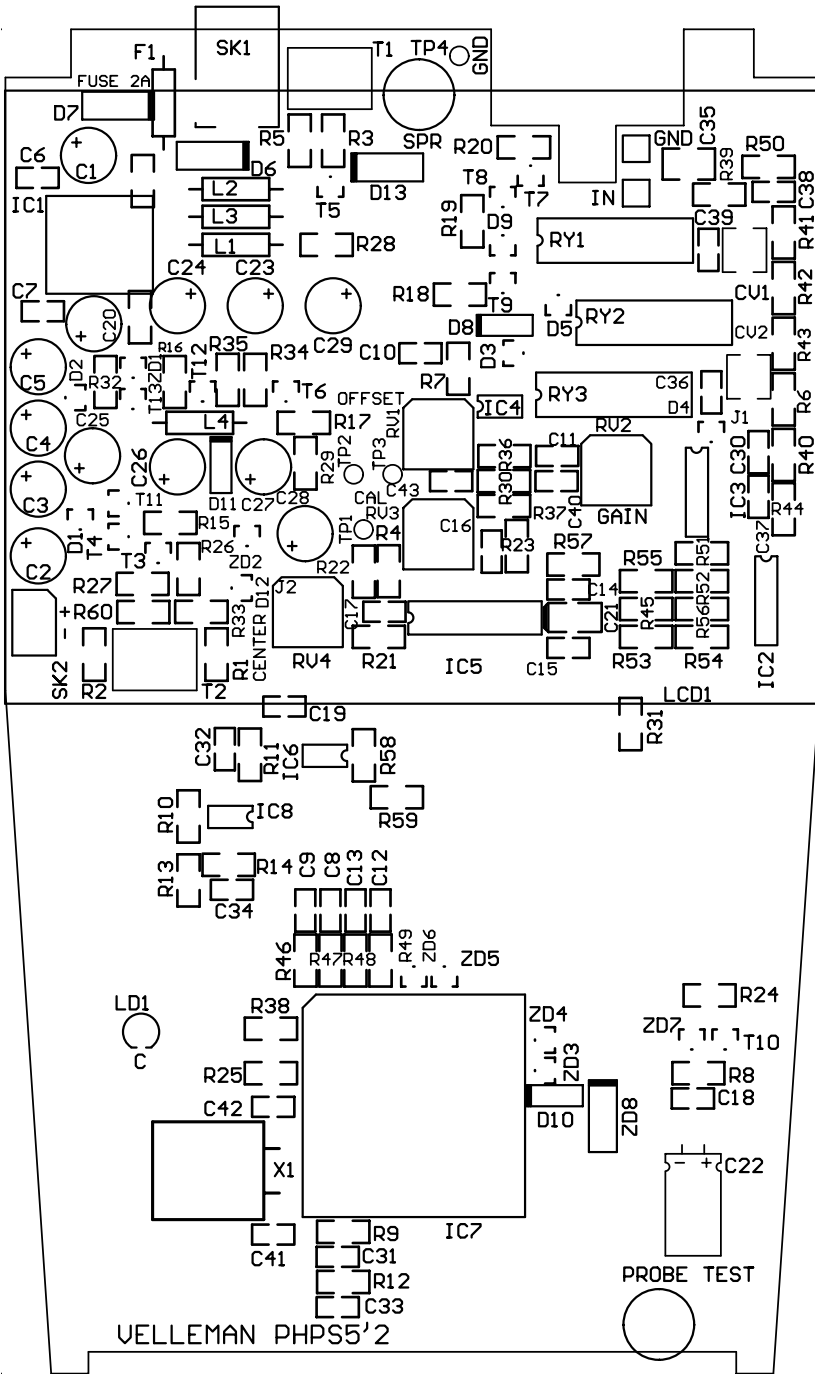

Test and calibration

Enter the hidden service menu to check the calibration

Enter Setup by long pressing Setup key

MODE	OFF TIMER	DISPLAY
Scope	√15 min.	DYNAMIC
Deno	ONE HOUR	√MANUAL
√Version	Disabled	
MENU		

Select "Version" with arrow keys and short press setup key to mark it, then leave setup by long pressing setup key.

HPS 10
VELLEMAN INSTRUMENTS copyright November, 2002 Build 061102F01

You should see the Version screen,

Now press ALL the keys one after the other starting with the power key and ending with the RIGHT arrow key

IMPORTANT:

PERFORM THE ADJUSTMENT IN THE ORDER AS DESCRIBED, ELSE THE COMPLETE ADJUSTMENT MUST BE REPEATED !

STEP 1, Offset adjustment.

Adjust RV1 until pass is indicated.
The trace on the screen must then remain stable.

See trimmer location

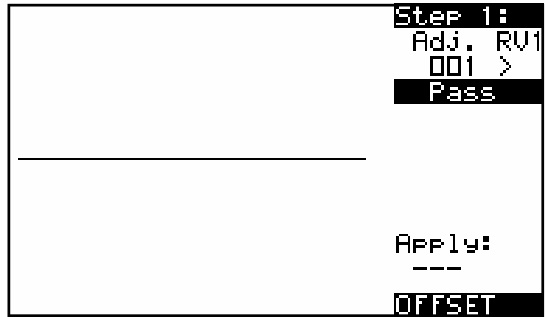

TRIMMER LOCATION:

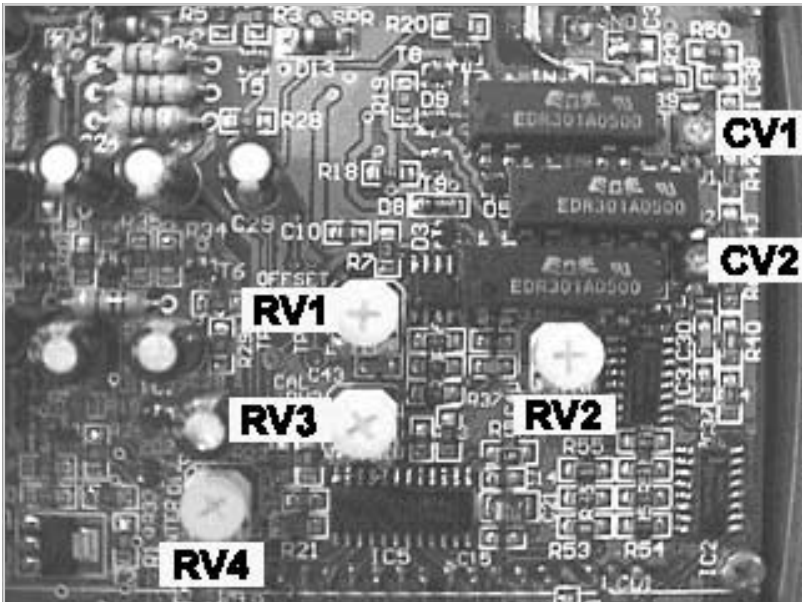

TIP: Pressing Right or Left arrow key, scrolls through the calibration screens

Press RIGHT ARROW KEY,

STEP 2, Low level transient

Connect the (x1) probe to the scope probe test output,

If necessary adjust CV1 until pass is displayed

See trimmer location

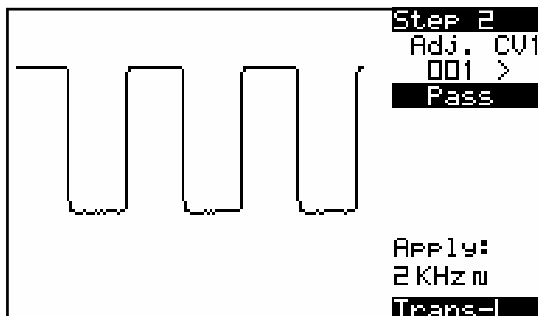

Press RIGHT ARROW KEY,

STEP 3, High level transient

Connect the (x1) probe to the scope probe test output,

If necessary adjust CV2 until pass is displayed

See trimmer location

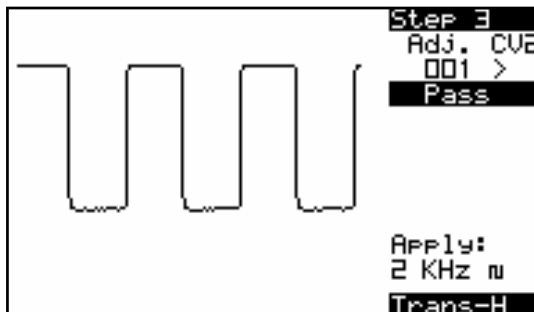

scope probe test output,

Press RIGHT ARROW KEY,

STEP 4, AD/DC Test

Signal should jump up and down.

No adjustment, if fail, check circuit round relay RY1, T7..

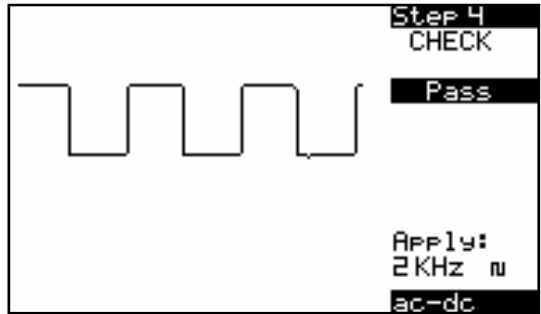

Press RIGHT ARROW KEY,

STEP 5, 50mV/div calibration

Connect the (x1) probe with a 0.17Vdc (170mV) supply

If necessary adjust RV3 until pass is displayed



Press RIGHT ARROW KEY,

STEP 6, 0.1V/div Gain calibration

Connect the (x1) probe with a 0.17Vdc (170mV) supply

If necessary adjust RV2 until pass is displayed



Press RIGHT ARROW KEY,

STEP 7, 0.2V/div test

Connect the (x1) probe with a 0.17Vdc (170mV) supply

No adjustment, if fail, check circuit round IC2, IC3, IC4

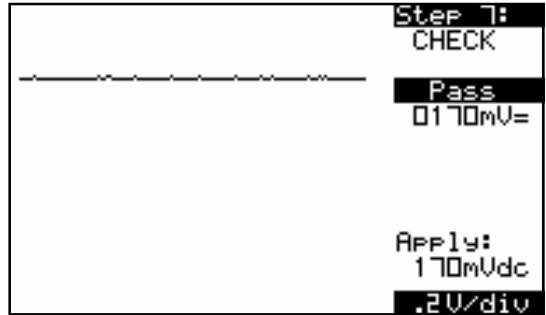

Press RIGHT ARROW KEY,

STEP 8, 0.4V/div test

Connect the (x1) probe with a 3.4Vdc supply

No adjustment, if fail, check circuit round IC2, IC3, IC4

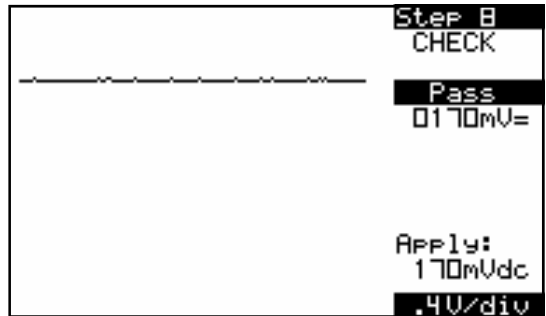

Press RIGHT ARROW KEY,

STEP 9, 1V/div test

Connect the (x1) probe with a 0.17Vdc (170mV) supply

No adjustment, if fail, check circuit round IC2, IC3, IC4

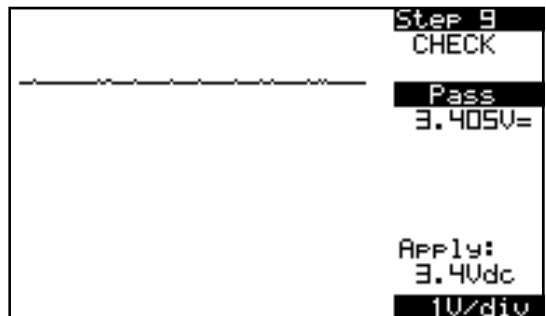

Press RIGHT ARROW KEY,

STEP 10, 2V/div test

Connect the (x1) probe with a 3.4Vdc supply

No adjustment, if fail, check circuit round IC2, IC3, IC4

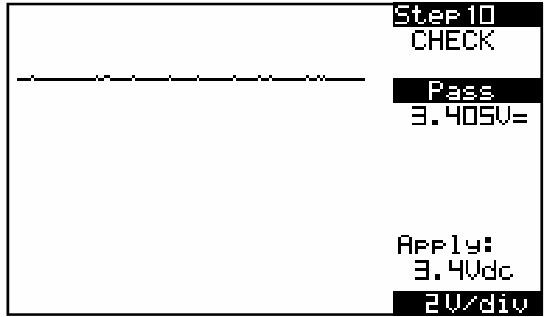

Press RIGHT ARROW KEY,

STEP 11, Trace center Adjustment

Disconnect the test probe. Adjust RV4 until pass is indicated.

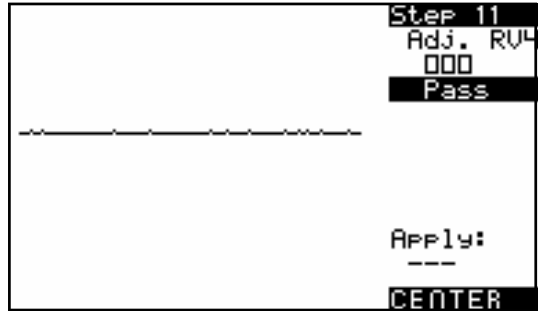

Press RIGHT ARROW KEY,

STEP 12, Calibration END

If all steps where correct "Pass" should be indicated. Due to possible manipulation Fail, could be indicated even if all tests where OK.

PRESS POWER OFF TO END THE CALIBRATION

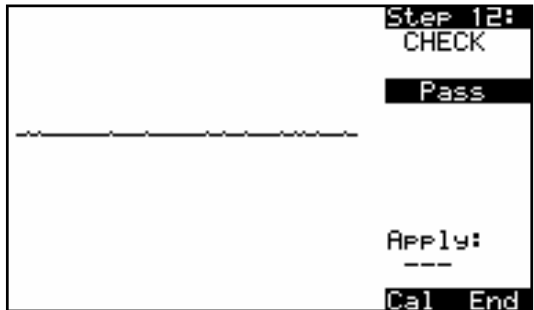

SPECIFICATIONS

Maximum sample rate	10MS/s for repetitive signals (2MS/s for single shot events)
Maximum input amplifier bandwidth	2MHz (-3dB at 50mV, 1V & 20V /div x1 setting)
Input impedance	1Mohm // 20pF (standard oscilloscope probe)
Maximum input voltage	100Vpeak (AC + DC), 200Vpeak-peak (AC only)
Input coupling	DC, AC and GND (GND for auto zero reference)
Vertical resolution	8 bit \pm 1bit linearity
Trigger modes	Run, Normal, Once, Roll mode for 1s/div and slower timebase
LCD Graphics	64 x 128 pixels
Signal storage	256 samples with 2 memories, max. 125 samples visible (256 using X shift)
dBm measurement (0dBm= 0.775V in 600ohm)	From -73dB tot +40dB (up to 60dB with X10 probe) \pm 0.5dB accuracy
dBV measurements (0dBV= 1V)	From -75dB tot +38dB (up to 58dB with X10 probe) \pm 0.5dB accuracy
True-rms measurement	From 0.1mV to 80V (up to 400Vrms with X10 probe) 2.5% accuracy
Peak to peak AC range (sinewave reference)	0.1mV to 160V (1mV to 1000V with x10 probe) 2% accuracy
Timebase range in 32 steps	0.2 μ s to 1hour / division
Input sensitivity range in 12 steps	5mV to 20V/division at X1- 50mV to 200V/div at X10
Probe calibration output	Approx. 2KHz / 5Vpp
Supply voltage	9VDC/ min 300mA adapter (unregulated) 12VDC if regulated
Batteries (option)	Alkaline type AA or Ni Cd / NiMH rechargeable (5 pcs required)
Charge current for rechargeable batteries	90mA
Battery life	Up to 20h with Alkaline batteries (OFF or standby current < 500 μ A)
Operating temperature	0 to 50°C (32 to 122°F)
Fysical characteristics	Dim: 105x220x35mm (4.13x7.95x1.38") Weight 395g (14oz.) ex. Batteries



A division of Velleman® Components

**Legen Heirweg 33
9890 Gavere
BELGIUM Europe**

www.vellemaninstruments.com

HPS10TD1.0