



**MAINTENANCE
AND USE MANUAL
PELLETS STOVE**



S-Z-M

CE



Dear client,

We thank you for having chosen one of our products. Our products are designed and made in accordance with the safety standards in force with high quality materials and a great experience about transformation processes. We recommend you to read carefully the instructions of this manual to obtain the best performance of your appliance.

This manual is an important part of the product: make sure you keep it always with the appliance, even if you give the appliance away to another person. Whether you lose it, ask for a copy to the nearest service centre.

• INDEX

• WARNINGS AND SAFETY	2
• PACKING	3
• CHIMNEY FLUE	3
• FUEL	8
• INSTALLATION	9
• USE	10
• SAFETY DEVICES	14
• MAINTENANCE	15
• TECHNICAL DATA	17
• IF THERE IS A PROBLEM	20
• GUARANTEE	23

• WARNINGS AND SAFETY

The stoves built in our factory are made with great care, also for individual components, in order to protect both the user and the installer from the possibility of accident. We therefore strongly advise skilled personnel, after any operation carried out on the product, to take special care with the electrical connections, especially the bare part of the conductors, which should not come out of the terminal board in any way, so as to prevent possible contact with the live parts of the conductor. When installing the appliance, comply with all local regulations and byelaws, including those referring to national and European legislation.

Installation should be carried out by skilled personnel, who will take complete responsibility for final installation and for consequent correct operation of the installed product. Fair will not be liable in the event of failure to respect these instructions.

This stove should be used for the purposes for which it was designed and made. The manufacturer is excluded from any contractual or extra-contractual liability for damage caused to persons, animals or objects, by errors in installation, adjustment or maintenance and by improper use. After removing the packing make sure the contents are complete and intact. If not, contact the retailer where the apparatus was purchased. The stove should be serviced at least once a year, by making an appointment in good time with the technical assistance services.

For safety reasons, always bear in mind:

This appliance should not be used by people (including children) with physical, sensory or mental limitations or by people with little experience or knowledge, unless they are supervised or receive instruction on how to use the appliance by the person who is responsible for their safety. Do not touch the stove if barefoot or if parts of the body are wet or damp. Never change the safety devices or adjustment devices without prior authorisation and instruction from the manufacturer.

Do not pull, detach or twist the electric cables coming out of the stove, even if it is disconnected from the power supply. Do not block or reduce the size of the openings for ventilation on the premises where the stove is installed. The ventilation openings are essential for correct combustion.

Keep the packaging out of reach of children and unassisted incapable people. Do not use the appliance as an incinerator or in any other way than that for which it has been designed. When the appliance is running its exterior, in particular, will reach high contact temperatures; handle with care to burns.

Do not make any unauthorised changes to the appliance. Use only original spare parts as recommended by the manufacturer.

- **PACKING**

Packing

The packing includes a cardboard box, which is recyclable in accordance with RESY guidelines, some recyclable inserts made of expanded EPS and wooden pallet. All package materials can be used again for similar use or taken away as solid urban waste in accordance with the regulation in force.

After you have taken the package away make sure the appliance is in perfect conditions.

Important: we recommend you move the appliance with adequate means paying attention to the safety regulation. Don't turn the package upside down and handle the majolica details with care.

- **CHIMNEY FLUE**

Introduction

This chapter gives you some directions for a good and correct fulfilment of the chimney flue but it doesn't replace the regulations in force that a qualified chimney setter should know.

The company declines any responsibility for the bad functioning of the stove if that is caused by a bad dimensioned chimney flue that is not in accordance with the regulation in force UNI10683.

Chimney flue

The chimney flue or chimney has a great importance for a heating appliance which uses solid combustible materials of b type with forced draft; as modern heating appliances are high efficient with colder fumes and a consequent lower draft it is really important that the chimney flue is properly built and always maintained perfectly efficient. The chimney flue must be single (regulation UNI7129/92) or going outside (regulation UNI7129/92) (see picture 1 a and b) which is not allowed in building with several floors and flats. It is not possible to connect more than one pellets appliance to the same chimney flue.

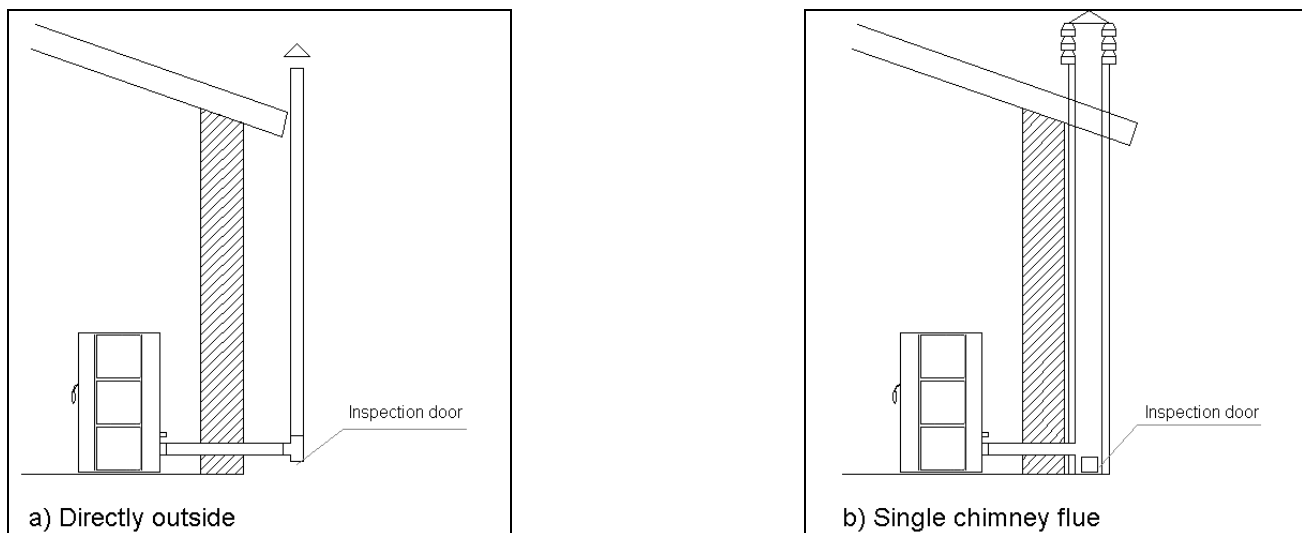

Pic. 1

Technical characteristics

The chimney flue must be fume tight (a seepage of air through cracks or an inspection door which isn't fume tight will highly reduce the draught of the chimney). It must be vertical without obstructions, made of materials that are impermeable to fumes and condensate, thermal insulated and adequate to be resistant against normal mechanical stress on a long term (we recommend chimneys made of a/316 or refractory material with double insulated chamber of round section). It must be insulated from the outside to avoid phenomenon of condensate and to decrease the effect of fumes cooling. It must be separated from materials that are combustible or easily inflammable by means of air space or insulating materials. The chimney fireplace throat must be located in the same room where the appliance is installed or at least in the next room and

PELLETS STOVE

underneath it there must be a chamber to collect solid residuals and condensate with a height not inferior to 50 cm and accessible through an airtight metal door. An expert stove setter should verify the chimney flue efficiency and if it is necessary the chimney flue must be ducted with materials in accordance to the standards in force. Auxiliary extractor fans can't be installed along the chimney or on the chimney pot.

Height - chimney draught

The chimney flue draught depends also on its height. The draught, which is necessary for the different models of pellets stoves, is: 15p/20p (0,15/0,20 mbar).

Dimensions

The section can be round (which is the best shape), square or rectangular (the ratio between the inner sides must be $\leq 1,5$) and the linked sides must have a minimum radius of 20 mm. The section dimensions must be equal to or bigger than the diameter of the fumes waste pipe (8cm). Hereunder you can see the dimensions table (see picture 2).

Type of system	Pipe Diameter 8 cm	Pipe Diameter 10 cm
Minimum length	1.5	2
Maximum vertical length (with 1 pipe tee)	6.5	10
Maximum length (with 3 pipe tees)	4.5	8
Maximum number of bends or pipe tees	3	4
Horizontal stretches (minimum gradient 5%)	2	2
Installation at altitudes over 1200 m above sea level	NO	Compulsory

Pic. 2

Chimney pot

The chimney pot is really important for a good functioning of a heating appliance, we recommend a chimney pot, which is wind resistant with wing profiles (see picture 3).

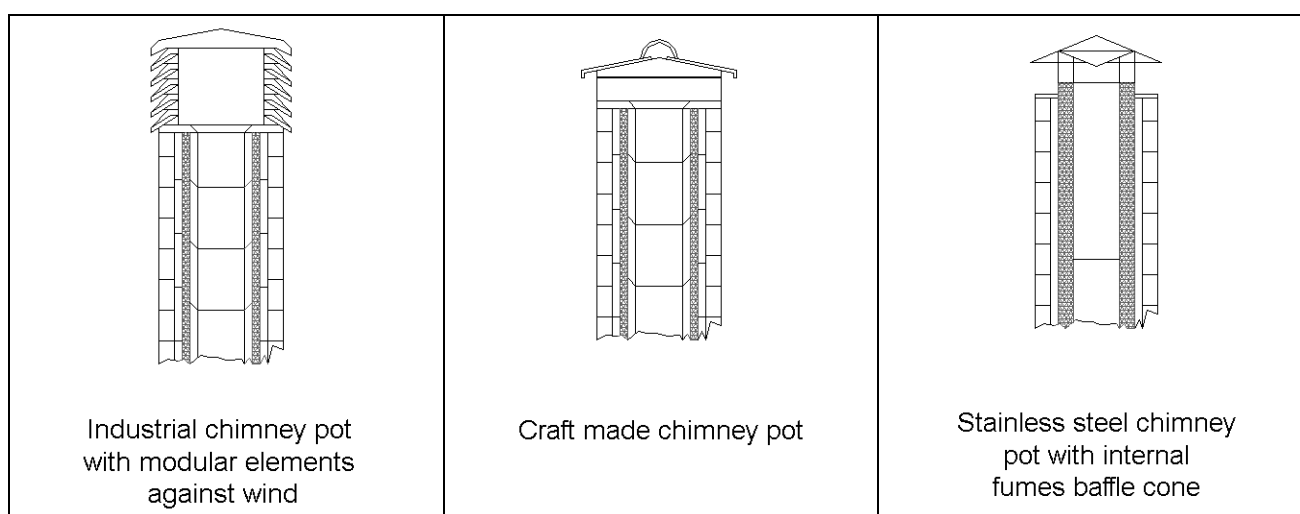

Pic. 3

It must present an outlet section not inferior to a double of the chimney section and it must be shaped to assure the outlet of fumes in case of wind coming from all directions and inclinations. It must stop rain, snow

and animals from going inside. The height of the fumes outlet in the atmosphere must be far away from the reflux area caused by the roof shape or by the presence of nearby obstacles (see picture 4).

Maintenance

The chimney flue must be kept always clean: deposits of soot or incombustible oils reduce its section in size obstructing its draught, compromising the good functioning of the stove and if the residuals are big they can catch fire. The chimney flue and pot must be cleaned and checked by an expert at least once a year. Safety can be compromised by the non-cleaning.

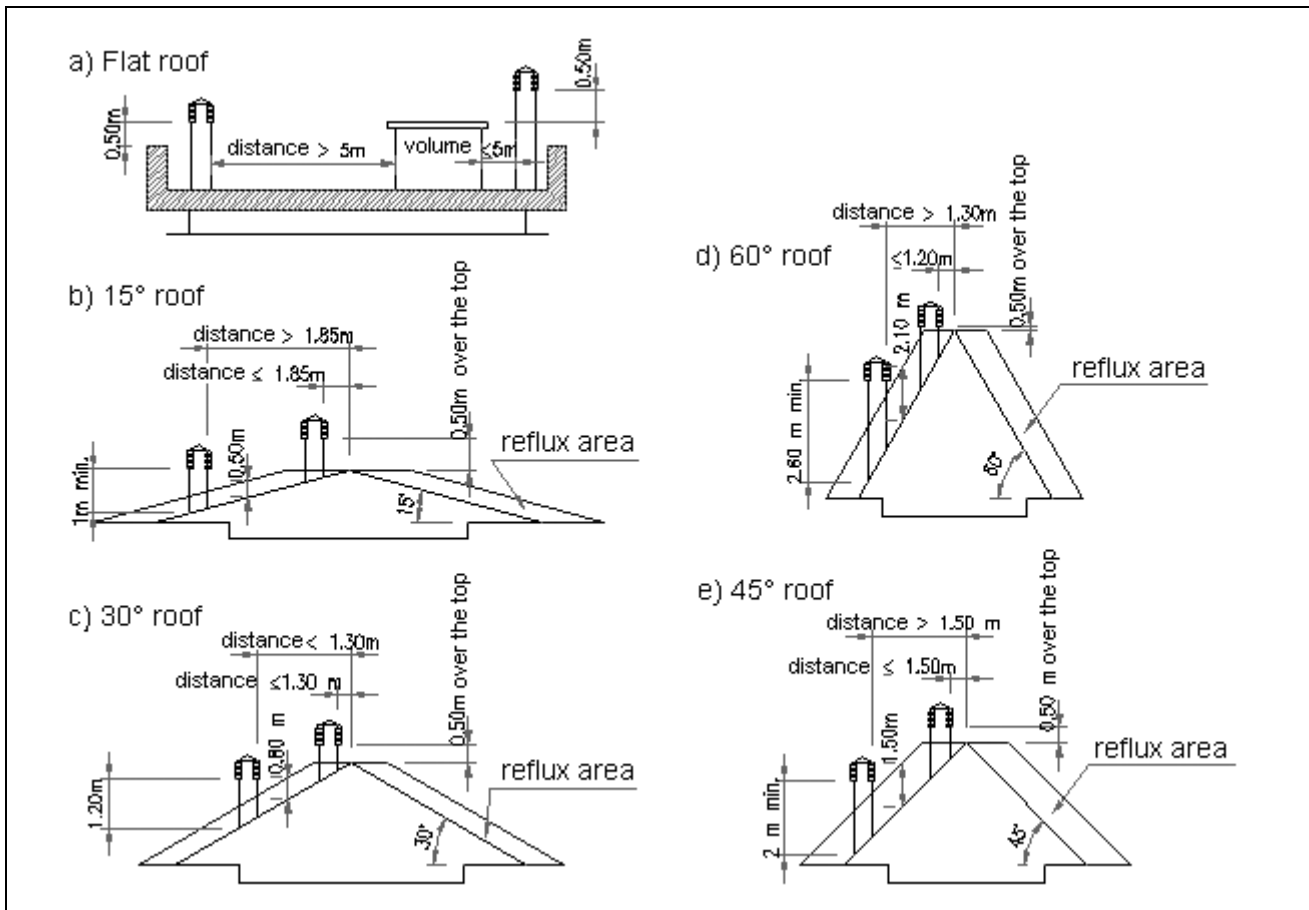

Pic. 4

External air intake

We recommend to set an air intake from the outside to have a healthy inner environment. The air flow between the outside and the room can be vented directly from a duct on the external wall of the room (best solution, see picture 5A pag.6) or indirectly from adjacent rooms (see picture 5B pag.6) as long as these rooms are not bedrooms, garages, store rooms, rooms that present the risk of fire or with an opposite draft due to a suction system without air intake. The air intake duct must have an inner cross section of at least $100cm^2$ but this parameter must be increased if there is an electric ventilation system to air the room (ex. Kitchen hood) (see picture 7 pag.7). The air intake duct must be located near the floor and safe from any accidental obstruction.

PELLETS STOVE

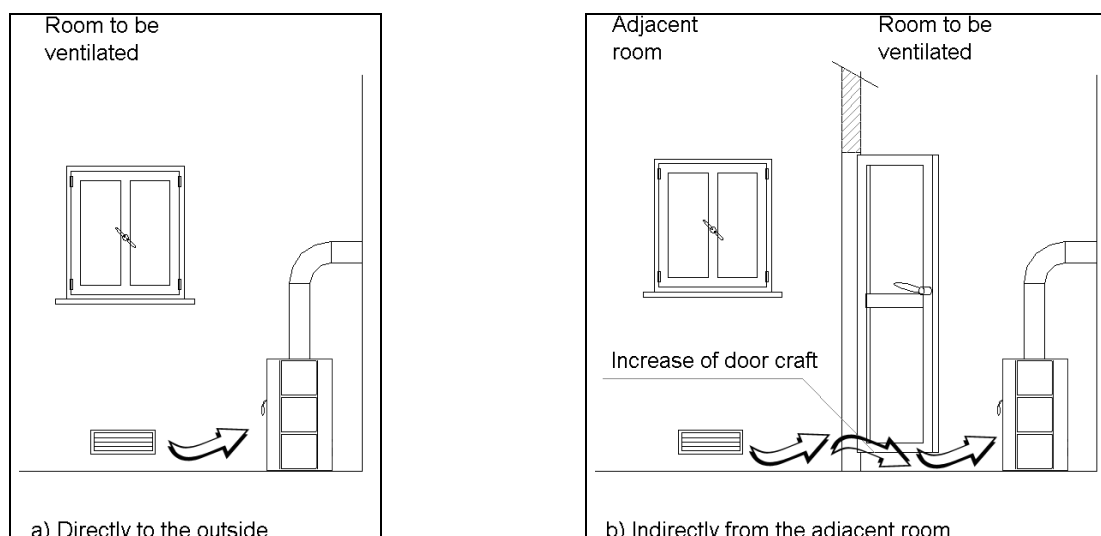

Pic. 5

Maximum capacity of electric ventilation(m ³ /h)	Net additional section (cm ²)
Up to 50	140
Over 50 and up to 100	280
Over 100 and up to 150	420

Pic. 6

Air necessary for combustion

All types of combustion need air (oxygen). Hence, every stove extracts air from the room in which it is installed and then the air has to be returned. Bad combustion may be caused by poor air circulation inside the house and this often occurs in modern homes, which have hermetically sealed doors and windows. The situation can also be problematical when, on the other hand, there are drafts inside the room (generated by fans in the kitchen or bathroom for example).

To avoid this type of problem we recommend installing a permanent ventilation grid in a window or near the stove. Air intake directly from the outside is compulsory.

WARNING!

Use only steel pipes. Pipes in synthetic material or aluminium must never be used.

Comburent air duct

We recommend to vent the flow of air for combustion purposes directly from the outside through a pipe with diameter 40 mm, located behind the stove (see page 17) that allows a better combustion with no risk against safety. When the installation takes place it is necessary to verify the minimum distances of the comburent air duct taken directly from the outside as (for example) a window or an open door can take off the comburent air necessary to the stove (see hereunder table). The duct outlet must be covered with a grid strainer against birds. If extractor fans are used in the same room or place where the appliance is installed this may create problems.

PELLETS STOVE

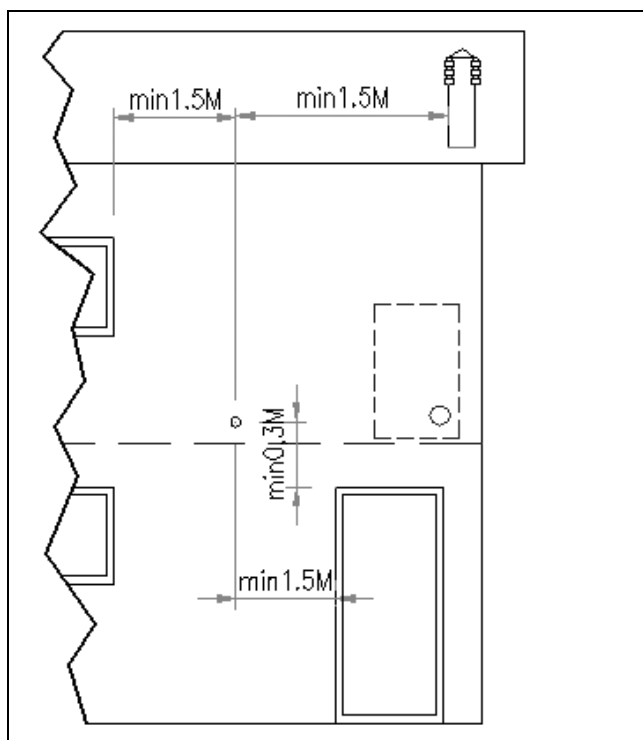

Pic. 7

The air intake must be at a distance of:		
1.5 m	Below	Doors, windows, fume exhaust, air spaces etc.
1.5 m	Level with	Doors, windows, fume exhaust, air spaces etc.
0.3 m	Above	Doors, windows, fume exhaust, air spaces etc.
1.5 m	Far away	Smoke outlet

Pic. 8

Connection to the chimney flue

A pellets stove works with a fumes draft forced by a ventilator, therefore you must be sure that all piping is properly made as explained in this chapter by specialised staff. The pipes fitting between the stove and the chimney flue must be short in order to support the draft and avoid the formation of condensate inside the pipes. The diameter of the fumes pipe must be equal to or bigger than the diameter of the waste fumes pipe (diameter 80mm). For the fumes pipe fitting you should use pipe made of plate for stove-setting, type B22 with silicone strips, pipes of painted aluminates steel (minimum thickness 1,5mm) or made of stainless steel A316 or porcelain zed (minimum thickness 0,5mm) with a diameter of 80 mm or 100mm depending on the type of plant (see picture 2 pag.4), you can not use pipes made of asbestos cement or flexible metal. The pipes must be sealed with high temperature silicone (min. 250°) and fixed together with a self-threading screw with diameter 3.9. You must always use a T pipe fitting (see picture 8) with inspection plug, which allows an easy periodic cleaning of the pipes without having to disassemble them. Make sure that after the cleaning the inspection plugs are closed hermetically with good strip. For changes of direction you can only use 3 T pipefitting and the fumes pipe length must not exceed 2 meters of horizontal projection with a minimum gradient of 5% (see picture 2 pag.4). You can't link more than one appliance to the same fumes pipe, you can't direct the waste fumes coming from above hoods into the same fumes pipe, you can't discharge the combustion products through the wall directly to the outside or to close spaces in open air. You can't connect any other type of appliances (wood stoves, hoods, boilers etc.). You can't fit butterfly valves or anything that can block the fumes passage anyway.

Examples of correct installation

- 1) Installation with hole on the roof for the passage of the pipe using an adequate mineral insulator (rock wool, ceramic fibre with a density bigger than 80 kg/m^3). The hole diameter varies from 300 mm, if the hole is in contact with flammable materials (wood etc.), to 200 mm if in contact with non-flammable materials (cement, bricks, etc.). This rule is valid also for holes on the wall.
- 2) Old chimney flue, ducted with an external door for the cleaning.
- 3) External chimney flue made of insulated stainless steel pipes with double wall, diameter 8-10 cm, well fixed on the wall.
- 4) Ducts system of T pipe fittings for easy cleaning without the disassemble of the pipes.

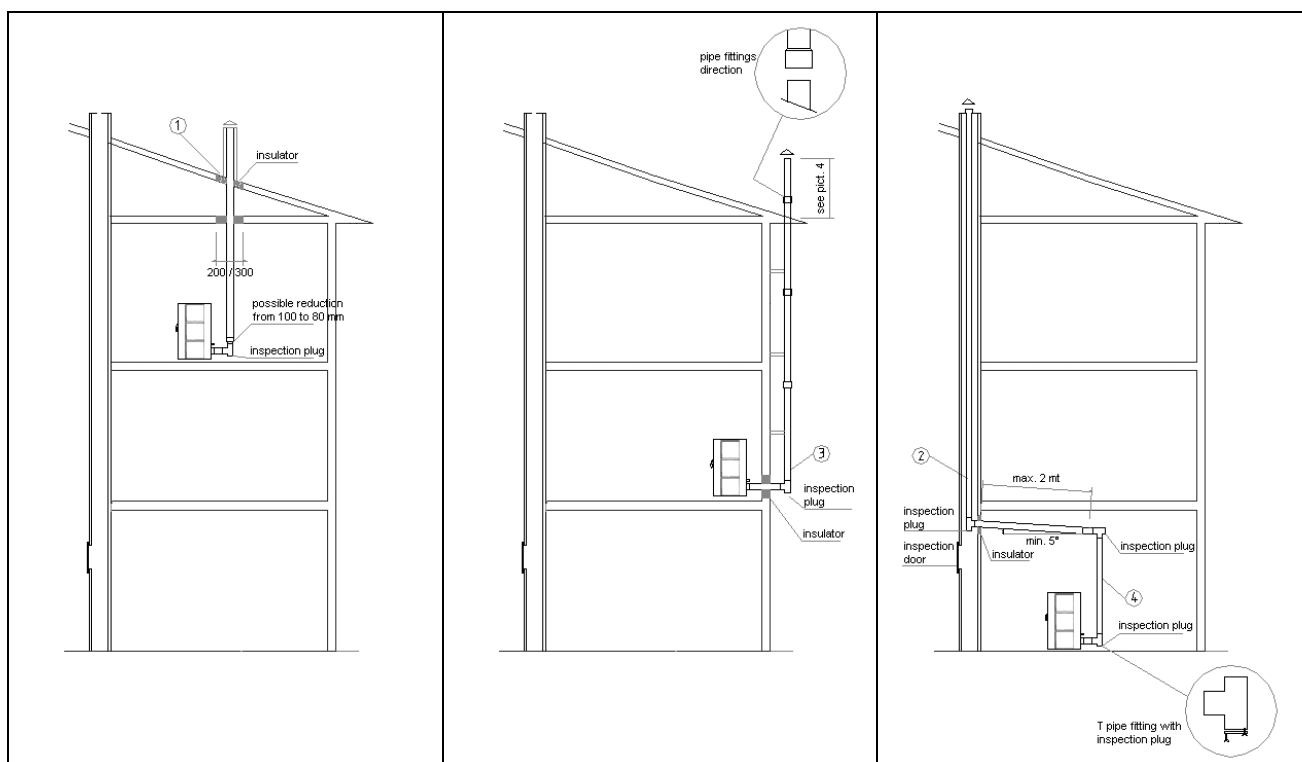

Pic. 9

• FUEL

Combustible material

Do not use inflammable liquids. Pellets are the only combustible material you can use. You can find different kind of pellets with different characteristics and quality on sale. We recommend to use pellets of good quality as that has great influence on the heating capacity and on the residuals of ash. Pellets characteristics are: diameter of 6-7 mm, maximum length 30 mm, they must be well pressed and little friable, without any residuals of glue, resin or additive. Not adequate pellets can cause bad combustion, frequent blockage of the brazier, obstruction of waste pipes, increase of consumption and decrease of heating power, dirtiness of the glass, increase of ash quantity or unburned granules. Any wet pellets causes bad combustion and bad functioning of the appliance, therefore make sure you store the pellets in dry rooms but at least 1 meter far from the stove or any other heating appliance. We suggest you to try different pellets on sale and then choose those with the best performance. The use of low quality pellets can damage the stove making the guarantee not granted and the manufacturer not responsible for the damage.

• INSTALLATION

Introduction

The stove position must be chosen in accordance with the environment, the waste pipe and the chimney flue. Verify with the local authority if there are restrictive rules about the air intake for combustion purposes and ventilation of domestic environment and about the waste fumes pipes plant with chimney flue and chimney pot. The manufacturer declines any responsibility in case of installation not in accordance with the standards in force, with a not correct ventilation system, an electrical connection not in accordance with the standards in force, or in case of bad use of the appliance. The installation must be carried out by a qualified technician who will sign a declaration of conformity of the system and take all responsibility for the installation and good functioning of the appliance. A booklet of testing and periodic maintenance to be carried out by the installer is issued to the client together with the stove.

Installation

The appliance should be installed on a floor with adequate load bearing capacity. If the existing structure does not satisfy this requirement it is essential to take appropriate precautions (e.g. install a load distribution plate). When the appliance is installed it should be placed so as to allow easy access for cleaning the stove itself, the exhaust gas ducts and the chimney flue.

The pellets stove must be installed in isolation, with a minimum air space of 15 cm to allow an adequate cooling of the appliance and a good distribution of heat in the domestic environment. In compliance with fire-prevention methods there must be a minimum distance of at least 20 cm from flammable objects (sofas, furniture, wooden covering) to the back and side of the stove and of 80 cm to the front where the fire door is. If the floor is made of flammable material you must prepare a coverage made of non-flammable material (plate of steel, marble, refractory material), which sticks out 50 cm from the front of the stove where the fire door is and 20 cm from the other sides (see picture 10). You can't install the stove in bedrooms or bathrooms.

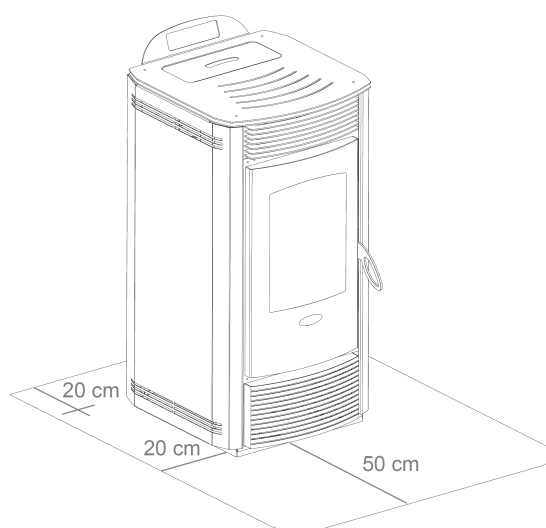

Pic. 10

Electrical connection

Important: the appliance must be installed by specialised staff. The electrical connection must be carried out using the supplied cable, adding an adequate plug on a socket which can take the load factor and voltage specific of each model as indicated on the technical data table (see page 17), the plug must be accessible when the appliance is installed. It is necessary that the fixed power grid is protected with a single pole switch to assure a complete disconnection with a minimum opening between the contacts of 3 mm. Make sure there is an efficient grounding, if there isn't one or it is inefficient you should provide to have a grounding installed in compliance with the standards in force.

N.B. The stove heating system is protected by two fuses located inside the main switch behind the stove. Always remember to disconnect the power supply before carrying out any maintenance and/or checks!

External thermostat connection

The stove starts thanks to a thermostat placed on its back, make sure you verify its position and don't place it near any kind of heating source. If you wish you can connect the stove to any kind of external environment thermostat. In that case you must use a cable of 2x0,5 mm², make it go through the pre-set hole under the tank and connect it to the electronic card (see wiring diagram pag.18). These operations must be carried out by a specialised technician.

Digital or mechanical thermostat

It is possible for the apparatus to control the ambient temperature by means of a digital thermostat that serves to reduce the heating power to minimum when a preset temperature is reached.

When the stove has been started off and it is in normal operation mode display A will show a number (21 C for example); this value is the ambient temperature.

Buttons P1 or P2 are used to enter thermostat setting mode and the display will show a message that will alternate with the word "set" and the temperature setting; pressing P2 will decrease this value while pressing P1 will increase it.

After adjusting to the desired temperature wait until the message "set" disappears from the display.

Use buttons P4 and P5 to adjust the desired heating power.

When the apparatus reaches the temperature setting it will automatically pass to operation at the lowest heating power and LED 4 will go off.

If you wish to disable digital thermostat operation, using P3 take the temperature to maximum so that the message "Hot" appears on display A. The remote control can also be used to perform the same operations.

Ventilation

The stove is provided with a ventilation system with dust filter. The air vented by the moto-ventilators keeps the stove temperature low preventing the materials the stove is made of from excessive stress and heating the domestic environment more homogeneously. Make sure you periodically test if the ventilator works properly. After removing the humidifying glass you can connect a pipe (diameter 8 cm) to vent some of the heated air to an other room. It is recommended that the pipe length doesn't exceed 3 meters not to loose the efficacy of the heated air.

• USE

Basic instructions

The stove that you have bought uses fuel in pellets. This type of material is made of natural wood chips from the wood processing industry. A special process that requires neither binders nor additives is used to compress the chips in industrial machinery at high pressure so that they become solid wood pellets. Use of raw materials that have not been made into pellets is ABSOLUTELY PROHIBITED in our stove.

Failure to respect this instruction will invalidate all guarantees and may have a negative affect on the safety of the apparatus.

For the first two or three times when you light the stove, bear in mind the following advice:

- Children should not be present, because the vapours emitted by the stove may be harmful to health. Adults should also avoid staying for long near the stove.

- Do not touch the surfaces as they may still be unstable.

- Air the room well several times.

-The surfaces will be fully hardened after several heating processes.

- Operate the stove at medium Power for 2-3 days (display A will show the number 3) so that the mechanical parts are able to settle into smooth running.

Important

Continuous operation of the stove at maximum power may shorten the expected life of the electrical components, we therefore advise against it. We suggest using the stove at maximum power only at the start, in order to bring the room quickly to the desired temperature (for an hour and a half for example).

The stove is designed for using pellets with a diameter of 6-7 mm. If you need to use pellets of different diameters, an authorised servicing engineer must first take it away for adjustment.

Introduction

It is recommended to follow the hereunder guidelines for the best functioning and least consumption. If the installation is well carried out and the fumes pipe is efficient the lightning of the pellets will be very easy. The procedure is as following: empty and clean the brazier, verify there are enough pellets in the tank. If you start the stove for the first time you should wait for the cochlea to be filled with pellets and that requires at least three attempts at starting, as the brazier is empty. Make sure the door is well close.

Important: don't use any kind of inflammable liquid during the lightning (alcohol, petrol, gasoline, etc.).

Important: at the first starting you should keep the fire lightning slowly for at least 24 hours to allow the materials the stove and the furnace are made of to settle the inner elastic stress avoiding permanent damages. Some greasy working residuals and paints can produce smell and smoke during the first hours of functioning, we recommend to air the room as they can be harmful to people and pets.

Important: the programming parameters from 1 to 5 are set by the company and can be changed only by an authorised technician.

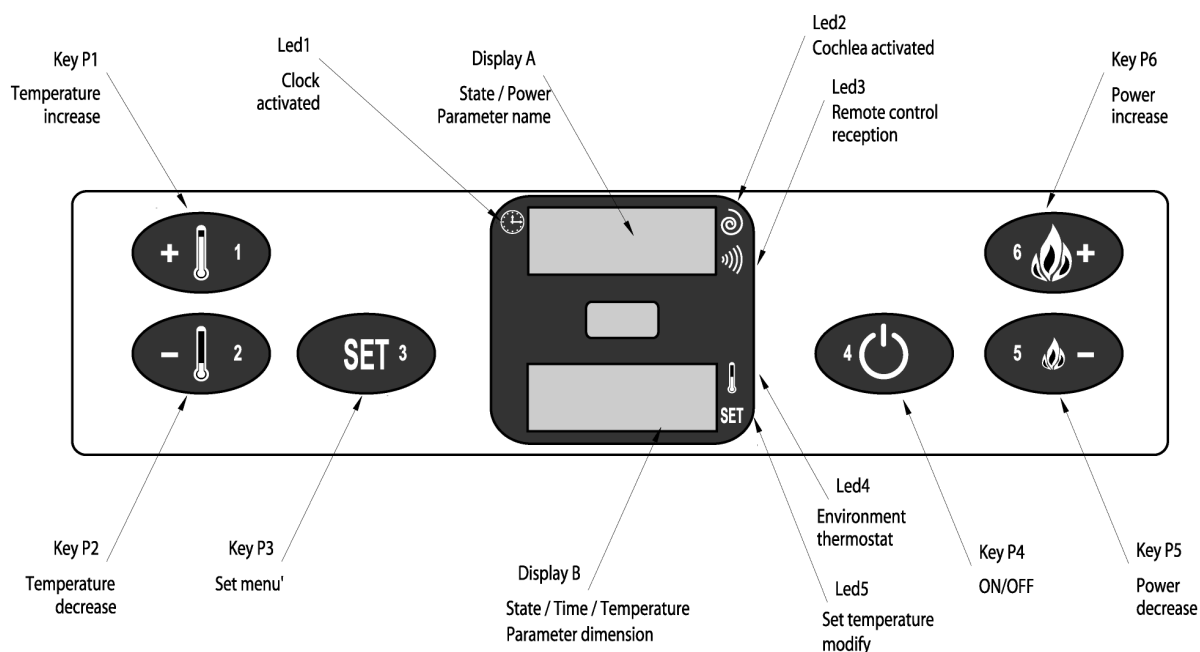

Pic. 11

Control panel

Key P1 and P2: when you are setting the temperature they increase or decrease the thermostat parameter from minimum 06°C to maximum 41°C. If you keep P1 pressed you can see the waste fumes temperature displayed. They both have programming function.

Key P3: to go to temperature and menu of parameters of the user and technician.

Key P4: (ON-OFF) to turn on and off, to unlock from alarms and go out from programming

Key P5 and P6: to increase or decrease the heating power from 1 to 5:

Led 1: active time programming

Led 2: if it is on the cochlea is activated

Led 3: to receive input from the remote control

Led 4: to turn on the thermostat

Led 5: it flashes when you are setting temperature or you are inside menu

Display A: during starting it shows the card state, during functioning it shows the heating power, when setting input it shows the parameter label you are changing.

Display B: during starting it shows the card state, during functioning it shows the temperature chosen by the user, during setting of inputs it shows the parameter you are changing.

Starting

To start the stove, keep key P4 pressed for few seconds, then the gear case will set the stove in a pre-ventilation state, displaying "Fan Cand", starting the extractor fan at minimum rate and the pre-heating of the starting resistance. After this phase which lasts 2 minutes, it will be displayed "Load Wood", the cochlea will

PELLETS STOVE

stoke pellets and the resistance will keep warming up. When the temperature is high enough, thanks to the fume gas feeler, the electronic gear case (after 7-10 minutes) will consider the starting phase ended and start the next phase of flame stabilisation displaying "FirE on" and starting the tangential ventilator (heat exchanger). When the "FirE on" phase ends, the gear case will set the work state, displaying the chosen heating power (you can change it with keys P6 and P5) and the environment temperature. During this phase keys P5 and P6 can regulate the stove power from 1 to 5. If the environment temperature exceed the limit parameter fixed on key-board during the temperature setting the heating power will decrease to minimum rate until the parameter is back to its prefixed limit and the display will show "RiS".

Non-starting

If pellets don't light up, the non-starting will be indicated by an alarm "AlAr no FirE". The stove starting takes about 7/10 minutes with good quality pellets and an environment temperature of about 10°C. If the environment temperature is lower, the starting plug is not able to start the stove; in this case you can help putting a lighted igniter on the brazier.

Energy failure

After an energy blackout, when the stove is restored it will display "AlAr no rEtE". The fumes gas extractor will discharge the fumes residuals for 20 minutes starting the switching off phase. When the cooling phase is completed, empty the brazier from excessive pellets and start the stove again.

To bypass the start stage (e.g. the fire goes out unintentionally): just press key (6) for about 2 sec. and the stove will immediately go into the ON operating phase; it is only possible to jump the startup phase if the smoke temperature (detected by the probe) is over 55°-60°C. Below these values, after several seconds the stove will return to the "Fan Cand" startup stage.

Temperature setting

To modify the environment temperature you can press any time key P3 together with P1 or P2 to regulate it. The chosen temperature and the environment temperature will be displayed on display b.

Fumes gas temperature

To verify the fumes gas temperature at the outlet keep key P1 pressed for few seconds.

Switching off

To switch off the stove keep P4 pressed, "OFF" will be displayed on display a. During this phase the stoking of pellets is stopped, the tangential fan is switched off and after 20 minutes the fumes extractor is turned off too (that occurs anyway if the stove is hot or cold).

To put off the fire

If it happens you suddenly have to put off the fire burst out from the stove or chimney flue, use carbon dioxide extinguisher (CO₂) or ask for the fire-brigade intervention. Do not use water to put off the fire in the brazier.

Pellets stoking

If you have to stoke the stove with pellets while it is working, make sure the pellets bag doesn't get in contact with any hot surface. Make sure the pellets tank is always closed with its lid. Don't put any residuals of combustible material (unburned embers) of the brazier into the pellets tank.

Clock setting

To set the clock press key P3 some times until the green led with the clock lights up and "UT02" is displayed, then you can regulate time with keys P1 and P2.

Weekly programming

You can plan the daily starting and switching off of the stove for 7 Days with 4 different programs. Remember pressing P4 you can exit from any program at any time you wish. The parameters of the clock-thermostat are:

UT01 to set the current date and the use modality (OFF means the exclusion of programming).

UT02 to set the current hour.

UT03 to set minutes.

UT04 to set technical parameters (reserved to technicians).

UT05 to set starting time program 1, with step of 10 min.

UT06 to set switching off time program 1, with step of 10 min.

UT07 to choose the weekdays with program 1 starting.

UT08 to set starting time program 2, with step of 10 min.

UT09 to set switching off time program 2, with step of 10 min.

UT10 to choose the weekdays with program 2 starting.

UT11 to set starting time program 3, with step of 10 min.

UT12 to set switching off time program 3, with step of 10 min.

UT13 to choose the weekdays with program 3 starting.

UT14 to set starting time program 4, with step of 10 min.

UT15 to set switching off time program 4, with step of 10 min.

UT16 to choose the weekdays with program 4 starting.

To verify if the clock-thermostat is working, go to UT01, the indication "Day" means it is activated, "OFF" means it isn't.

We explain you now some parameters meaning.

UT01 to set the weekly program on "Day" or deactivate it on "OFF". Select the weekday from "Day 1"= monday to "Day 7"= sunday. If UT01 is set on the current day (ex: Day 2 is tuesday) you can then select the weekday when you want to start program 1, 2, 3 or 4. Pressing P1 and P2 you can choose the wanted parameter.

UT05-UT06 indicates starting and ending time of the functioning of the stove in program 1. They are activated when UT01 is on weekly modality.

UT07 this parameter is activated when UT01 is on weekly modality. When program 1 is activated, with P1 you can choose the weekday and with P2 you activate or deactivate the starting of the stove and so on for all programs.

Example:

	Starting	Switching off	Mon. (Day1)	Tue. (Day2)	Wed. (Day3)	Thu. (Day4)	Fri. (Day5)	Sat. (Day6)	Sun. (Day7)
Progr. 1	UT05 h 07.00	UT06 h 09.00	ON	ON	ON	ON	ON	<i>OFF</i>	<i>OFF</i>
Progr. 2	UT08 h 11.00	UT09 h 13.00	ON	ON	ON	ON	ON	<i>OFF</i>	<i>OFF</i>
Progr. 3	UT011 h 17.00	UT012 h 21.00	ON	ON	ON	ON	ON	<i>OFF</i>	<i>OFF</i>
Progr. 4	UT014 h 10.00	UT015 h 20.00	<i>OFF</i>	<i>OFF</i>	<i>OFF</i>	<i>OFF</i>	<i>OFF</i>	ON	ON

Optional remote control

With the remote control it is possible to adjust the heating power, the desired ambient temperature and switch the apparatus on/off automatically.

To switch on the stove press buttons P1 and P6 simultaneously for 3 seconds; the apparatus will automatically enter the ignition stage. After the ignition stage it will enter normal operation mode and buttons P6 and P5 can be used to adjust the heating power. Pressing P1 or P2 will adjust the desired ambient temperature. To switch off the stove keep buttons P1 and P6 pressed simultaneously for 3 seconds, display A will show the message "Off".

The remote control operates with a 12 Volt MN21 type battery.

The batteries should be removed from the device before it is disposed of and must themselves be disposed of safely.

Carry out the following operations to change the batteries:

- use a screwdriver to loosen the screw on the back of the remote control;
- slide out the cover and replace the batteries, taking care to orient the polarities correctly;
- close the cover and tighten the screw.

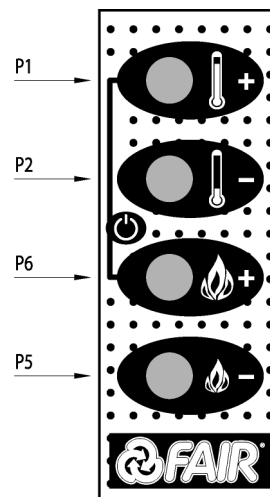

Pic. 12

• SAFETY DEVICES

Introduction

Safety devices are useful to prevent and avoid risks of damages to people, pets or property. You should avoid to tamper with them or call non-authorized staff to have them repair, making the guarantee not valid and the manufacturer not responsible for them.

Pressure switch alarm

A pressure switch is connected to the boiler pipeline to check the depression. If “AlAr dEP” appears on display the pressure switch stops the electric input to the cochlea blocking the pellets stoking to the brazier and starting the switching off phase. The electronic card makes the fumes extractor work at maximum speed and then turns it off within 20 minutes. Switch the stove off with ON/OFF key. Verify the occurring fault on page 20. After detecting the cause of the fault, clean up the brazier and restart the stove with ON/OFF.

Thermocouple fumes feeler alarm

A feeler, which controls constantly the temperature, is connected to the fumes waste duct. When the feeler is damaged or disconnected “AlAr Sond” will appear on display. The electronic card stops the electric input to the cochlea blocking the pellets stoking to the brazier and starting the switching off phase. The electronic card keeps the fumes extractor working for 20 minutes to cool the stove down. Let the stove cool down, and then switch it off with ON/OFF. Verify the occurring problem on page 20. After solving the problem clean up the brazier and start the stove with ON/OFF.

Alarm of non-starting

The fumes thermocouple takes control of the stove in case of non-starting when the temperature is not high enough to allow the starting. When “AlAr no FirE” appears on display the feeler through the electronic card starts the turning off phase after 20 minutes. Verify the occurring problem on page 20. After solving the problem clean up the brazier and start the stove with ON/OFF.

Over-heating alarm

If the fumes feeler detects a temperature higher than 200°C at the fumes waste duct, “RiS” will appear on display, the pellets stoking is decreased and the card makes the fumes extractor work at its maximum speed to take the temperature back to the set limits. If temperature shouldn't decrease but increase up to 215°C the stove starts the switching off phase. Verify the occurring problem on page 20. After solving the problem clean up the brazier and start the stove with ON/OFF.

Switching off alarm

If the fumes feeler detects a temperature lower than the minimum limit, “AlAr no FirE” will appear on display. That means the fire went out and the electronic card starts the switching off phase. Verify the occurring problem on page 20. After solving the problem clean up the brazier and start the stove with ON/OFF.

Energy black out alarm

After an energy black out “AlAr no rEtE” will appear on display. The fumes extractor will clear up the fumes residuals for 20 minutes starting the switching off phase. When cooled down, verify the occurring problem on page 20. After solving the problem clean up the brazier and start the stove with ON/OFF.

Tank safety alarm

There is a manual winding thermostat near the tank, which controls if the temperature exceeds the allowed limits preventing in this way the pellets from catching fire because of the over-heating. “AlAr Sic” will appear on display and the thermostat stops the electrical input to the cochlea blocking the pellets stoking of the brazier and starting the switching off phase. Let the stove cool down and then switch it off with ON/OFF. Verify the occurring problem on page 20. After solving the problem wind the thermostat: unscrew the black cap, press the black button and screw the cap back. Clean up the brazier and restart the stove with ON/OFF.

• MAINTENANCE

Introduction

To extend the life of your stove it is important to clean it periodically as indicated hereafter. It is also necessary to have an extraordinary maintenance intervention done on the stove and chimney once a year calling the assistance service on time. Do not use steel-wool, muriatic acid or corrosive and scratching products to clean its inner and exterior parts. In case of damages always use original spare parts asking to authorised shops or to the manufacturer.

Important: before cleaning or performing maintenance let the fire go out completely and the stove cool down and disconnect it from electrical power supply.

Filter cleaning

The stove is equipped with a filter against dust, which is placed on the air ventilation duct on the stove back and must be cleaned once a month. Take the filter out and wash it without water.

Majolica parts cleaning

We would like to remind you that the majolica parts are craft-made and therefore they can have little flaws (flaws interlacing due to thermal dilation between the biscuit and the paint), marking by tricks (very little holes due to microscopic gas blisters that appear on surface during the cooking) shadings (shades of paint due to concentration of colour in particular areas of majolica). To clean the majolica parts you should use a dry and soft cloth. If you use any kind of detergent that will filter through the flaws showing them up.

Painted metal parts cleaning

Use a wet soft cloth to clean the painted metal parts. Do not use degreasing substances, alcohol, diluent, acetone, petrol that can damage irreparably the paint.

Glass cleaning

The fire-door pyroceram resists to 700°C but not to sudden changes of temperature. Therefore you can clean the glass with normal glass products but you have to wait for the glass to cool down to avoid its explosion. If you break the glass you must replace it before using the stove.

Fumes ducts cleaning

Using brushes clean the soot from: the fume duct, the chimney flue and the chimney pot. A specialised technician should carry out this cleaning and verify its effectiveness.

Fumes chamber cleaning

Every two weeks it is recommended to clean the fumes chamber.

PELLETS STOVE

Open the door only when the stove is off. Clean it sucking the ash left inside. After cleaning repeat the opposite operation to make sure of the good conditions and efficiency of the strip and when necessary replace it.

Firebox cleaning

Every two weeks you should clean the firebox (see picture 13). Open the door only when the stove is off. Remove the fire pot. Clean it sucking the ash left inside the firebox. After cleaning repeat the opposite operation.

Brazier cleaning

It is recommended to clean the brazier every two days (see picture 13). Open the door only when the stove is off. Remove the brazier from its seat lifting it up, empty it from the ash and if necessary use a pointed tool to clean the obstructed holes. Clean also the brazier room from ash left inside. The frequency of the cleaning depends on the type of pellets. Pay attention to the flame colour, if it is red that means it is weak, if there is black smoke that means the brazier is dirty and it must be cleaned.

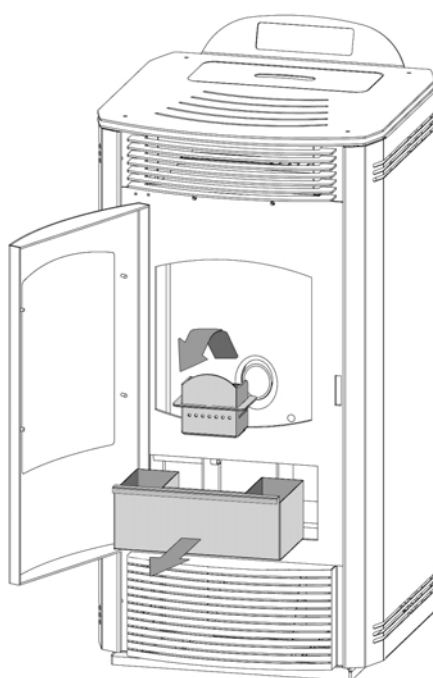

Pic. 13

Ash draw cleaning

You must empty the ash draw when full. The ash should be put in a metal container with airtight lid and it shouldn't get in contact with combustible material (ex: left on a wooden floor) as the ash keeps the live coal lighted for long time. Clean also the draw room from eventual residuals (see picture 13).

Fumes duct cleaning

It is recommended to clean the waste fumes pipes once a month (see picture 9 pag.8).

Remove the inspection plug of the T pipe-fitting (when the stove is off). Clean it from the ash left inside. After cleaning repeat the opposite operation verifying the good conditions and the efficiency of the strip and if necessary replace it.

Important: close hermetically the plug otherwise the toxic fumes gas will spread in the room.

Strip replacement

When the strip of the fire door or fumes chamber door is damaged it is necessary to replace it to make the stove work properly. Take the strip off and replace it with original spare parts. Call a specialised technician to replace it.

• TECHNICAL DATA

Characteristics

Descrizione	S7	S6	ZC12	Z12	MC10	M10
Width	50,2cm	50,2cm	50,3cm	47,4cm	50,3cm	47,4cm
Depth	50,6cm	50,6cm	50,6cm	50,6cm	50,6cm	50,6cm
Height	103,5cm	100cm	100cm	100cm	92cm	92cm
Weight	115kg	113kg	104kg	95kg	99kg	90kg
Global Rated thermal power	12kw	12kw	12kw	12kw	10kw	10kw
Rated thermal power (min-max)	3-10,5kw	3-10,5kw	3-10,5kw	3-10,5kw	3-8,5kw	3-8,5kw
Hour consumption (min-max)	0,6-2,4kg/h	0,6-2,4kg/h	0,6-2,4kg/h	0,6-2,4kg/h	0,6-2kg/h	0,6-2kg/h
Efficiency	>89%	>89%	>89%	>89%	>91%	>91%
Chimney depression	7-11pa	7-11pa	7-11pa	7-11pa	7-12pa	7-12pa
Emissions CO at 13% of O ₂	0,01-0,06%	0,01-0,06%	0,01-0,06%	0,01-0,06%	0,01-0,06%	0,01-0,06%
Emissions CO ₂	5,5-12%	5,5-12%	5,5-12%	5,5-12%	5,5-11%	5,5-11%
Average temperature fumes	78-206 °C	78-206 °C	78-206 °C	78-206 °C	78-167 °C	78-167 °C
Mass flow fumes	3,3-5,6 g/s	3,3-5,6 g/s	3,3-5,6 g/s	3,3-5,6 g/s	3,3-5,0 g/s	3,3-5,0 g/s
Tank capacity	25kg	25kg	25kg	25kg	20kg	20kg
Fumes waste outlet diameter	80mm	80mm	80mm	80mm	80mm	80mm
Comburent air duct diameter	50mm	50mm	50mm	50mm	50mm	50mm
Volume to heat (min-max)	150-315 m ³	150-315 m ³	150-315 m ³	150-315 m ³	150-255 m ³	150-255 m ³
Autonomy (min-max)	10-42h	10-42h	10-42h	10-42h	10-33h	10-33h
Electrical input	230v-50hz	230v-50hz	230v-50hz	230v-50hz	230v-50hz	230v-50hz
Maximum power intake	250w	250w	250w	250w	250w	250w
Max rated elec. power cons.	40w	40w	40w	40w	40w	40w
Heated air capacity (max)	260m ³ /h	260m ³ /h	260m ³ /h	260m ³ /h	260m ³ /h	260m ³ /h

Pipes fitting dimensions

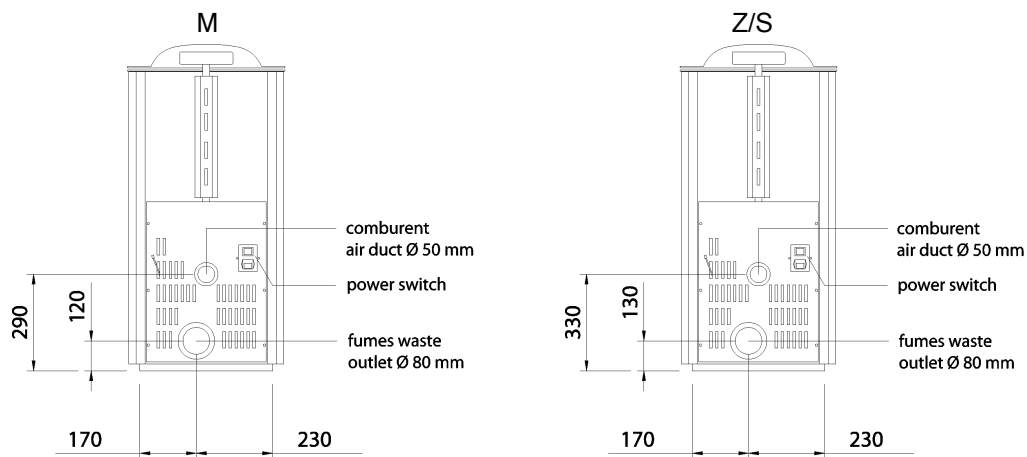
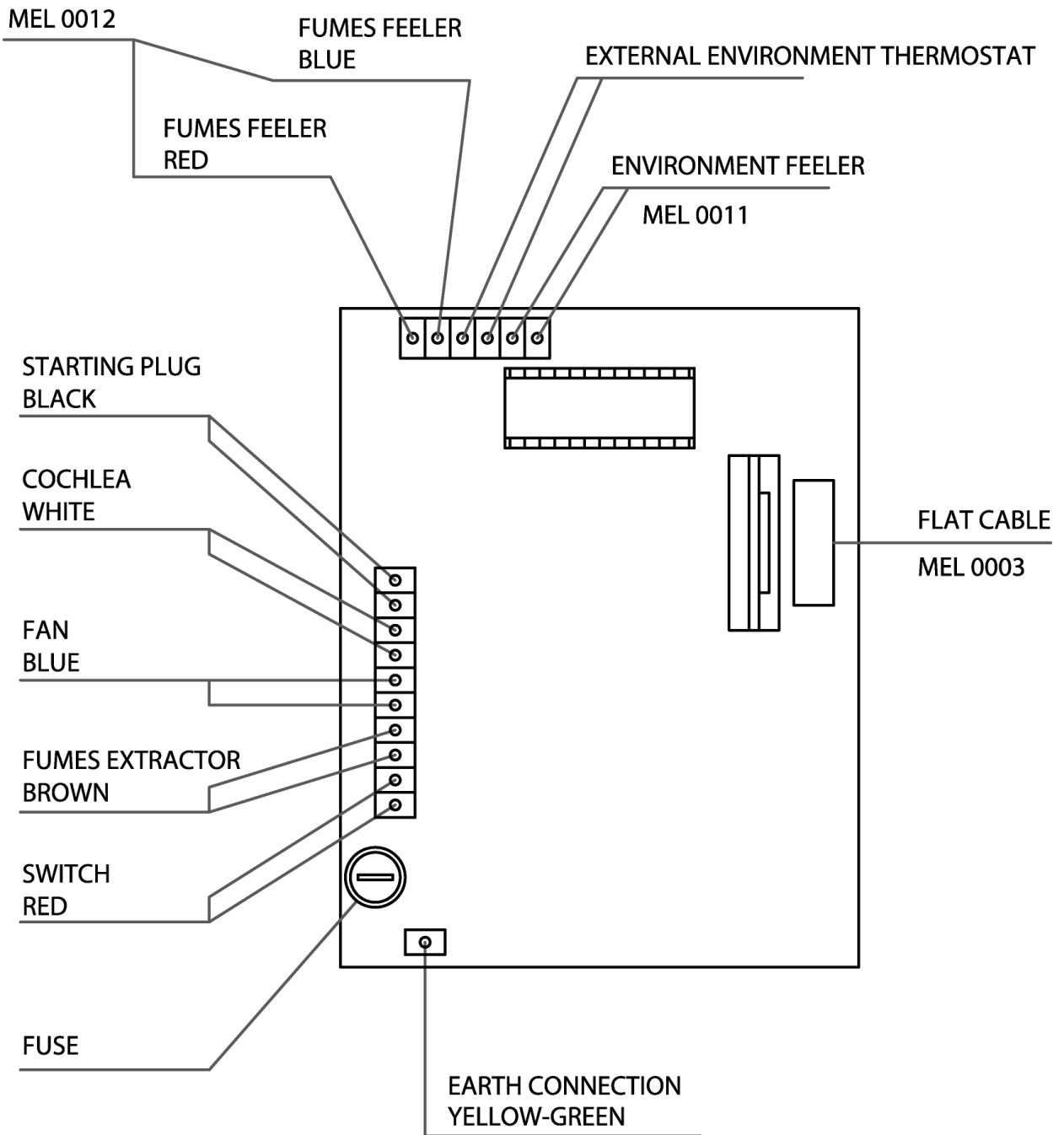

Fig. 14

The above indicated data can be changed. The manufacturing company can modify any of them if necessary to improve the products characteristics. The efficiency rating refers to premises with insulation conforming to local standards.

PELLETS STOVE

Wiring diagram



EVENTUAL PRESSURE SWITCH CONNECTED IN SERIES WITH COCHLEA CABLE

PELLETS STOVE

• IF THERE IS A PROBLEM

Problem	Cause	Solution
<ul style="list-style-type: none"> The control panel doesn't start 	<ul style="list-style-type: none"> The stove hasn't got electrical input Card protection fuse is burned Control panel is faulty Flat cable is faulty Electronic card is faulty 	<ul style="list-style-type: none"> Verify if the plug is connected Replace the fuse. Call a specialised technician Replace the control panel cod.Com0241. Call a specialised technician Replace the flat cable cod.Com0240. Call a specialised technician Replace the electronic card cod.Com0231. Call a specialised technician
<ul style="list-style-type: none"> The stove doesn't start. Alarm displayed: "AlAr no FirE" 	<ul style="list-style-type: none"> The tank is empty The brazier isn't cleaned The feeler hasn't detected the minimum threshold to start Starting plug is faulty Outside temperature is too cold Pellets are wet Thermal feeler is blocked Electronic card is faulty 	<ul style="list-style-type: none"> Fill the tank Clean the brazier (see Maintenance) Empty the brazier and start again, if the problem continues call a specialised technician Replace the plug, cod Com0234. Call a specialised technician Restart the stove Pellets must be stored in a dry room. Verify Replace the feeler, cod Com0139. Call a specialised technician Replace the card, cod Com0231. Call a specialised technician
<ul style="list-style-type: none"> Pellets don't get to the fire box 	<ul style="list-style-type: none"> The tank is empty Cochlea is blocked by a strange object (ex. Nails) Cochlea gear motor is damaged Verify if there is an alarm activated on display (ex. AlAr dEP., AlAr Sic.....) 	<ul style="list-style-type: none"> Fill the tank Unplug the plug, move the inside hand protection of the tank, empty the tank, clean the cochlea e start again Replace the gear motor, cod Com0232. Call a specialised technician Call a specialised technician to check the stove and detect the problem
<ul style="list-style-type: none"> The fire goes out and the stove stops 	<ul style="list-style-type: none"> The tank is empty Cochlea is blocked by a strange object (ex. Nails) Pellets aren't of good quality The phase 1 parameter set in the electronic card is too low Verify if there is an alarm activated on display (ex. AlAr dEP, AlAr Sic.....) 	<ul style="list-style-type: none"> Fill the tank Unplug the plug, move the inside hand protection of the tank, empty the tank, clean the cochlea e start again Try different types of pellets The pellets supply must be regulated by a specialised technician Call a specialised technician to check the stove and detect the problem
<ul style="list-style-type: none"> The fire has a weak and orange flame, pellets don't burn correctly and the glass gets black 	<ul style="list-style-type: none"> The air for combustion isn't enough The waste pipe is blocked The stove is obstructed Fumes extractor is damaged 	<ul style="list-style-type: none"> Check the following: possible obstructions of the air inlet on the back of the stove: brazier grid holes obstructed and/or brazier box with too much hash: exchanger pipes too dirty; clean the extractor blades and its scroll (see Maintenance) Exhaust chimney is partially or totally obstructed (call an expert)

PELLETS STOVE

		<p>stove fitter to check the chimney from the stove outlet to the chimney pot). Have it cleaned immediately.</p> <ul style="list-style-type: none"> • Clean the stove inside (see Maintenance) • Pellets can burn thanks to the chimney flue depression without the aspirator. Have it replaced immediately (cod. Com0236) as it can be bad for your health. Call a specialised technician.
<ul style="list-style-type: none"> • The exchanger fan keeps working when the stove is cold 	<ul style="list-style-type: none"> • Temperature fumes feeler is faulty • Electronic card is faulty 	<ul style="list-style-type: none"> • Replace the fumes feeler, cod Com0239. Call a specialised technician • Replace the card, cod Com0231. Call a specialised technician
<ul style="list-style-type: none"> • Hash around the stove 	<ul style="list-style-type: none"> • Faulty or damaged doors strips • Fumes pipe tubes are not airtight 	<ul style="list-style-type: none"> • Replace the strips cod. Com0244+Com0245 • Seal immediately the pipe fitting (with high temperature silicone) and/or replace the pipes with new ones. Fumes pipes that aren't airtight can be dangerous for your health. Call an expert stove fitter.
<ul style="list-style-type: none"> • The stove switches off. Alarm displayed "AlAr no rEtE" 	<ul style="list-style-type: none"> • Plug accidentally unplugged • Temporary power failure • Faulty electronic card 	<ul style="list-style-type: none"> • Verify the plug is plugged in • Verify the power failure and start the stove again • Replace the card, cod Com0231. Call a specialised technician
<ul style="list-style-type: none"> • The stove is in steady condition, the display shows: "RiS" 	<ul style="list-style-type: none"> • Environment temperature reached • Fumes outlet temperature reached 	<ul style="list-style-type: none"> • The stove works at minimum rate: no problem • The stove works at minimum rate: no problem
<ul style="list-style-type: none"> • When working normally the stove display shows "Stop Fire" 	<ul style="list-style-type: none"> • Cleaning grate 	<ul style="list-style-type: none"> • The stove goes to minimum and extraction ventilation to maximum: no problem
<ul style="list-style-type: none"> • The stove switches off. Alarm displayed: "AlAr dEP" 	<ul style="list-style-type: none"> • The door isn't closed • The waste outlet is obstructed • Fumes extractor is damaged • Rubber connection is obstructed • Pressure switch is faulty • Electronic card is faulty • Excessive chimney length • Bad weather conditions 	<ul style="list-style-type: none"> • Closed the door properly and check the door strips are in good conditions otherwise replace them cod. Com0244+Com0245 • The fumes waste chimney is partially or totally obstructed (call an expert stove fitter to check the chimney from the stove outlet to the chimney pot). Have it cleaned immediately. • Pellets can burn thanks to the chimney flue depression without the aspirator. Have it replaced immediately (cod. Com0236) as it can be bad for your health. Call a specialised technician. • Take the silicone pipe off and with the help of a pointed tool clean the bodying hole. Replace the pipe if necessary cod. Com0401 • Replace the pressure switch, cod Com0233. Call a specialised

PELLETS STOVE

		<p>technician</p> <ul style="list-style-type: none"> • Replace the card, cod Com0231. Call a specialised technician • Call an expert stove setter to verify if the chimney is according to the law (see paragraph 2) • When there is a very strong wind a negative depression to the chimney can occur. Verify and start the stove again
<ul style="list-style-type: none"> • The stove switches OFF. Alarm displayed "AlAr Sic" 	<ul style="list-style-type: none"> • Stove overheated • The exchanger fan doesn't work • Temporary power failure • Faulty thermostat • Air filter obstructed • Faulty electronic card 	<ul style="list-style-type: none"> • Let the stove cool down and stoke it again, if the problem continues call a specialised technician • Replace the fan, cod Com0237. Call a specialised technician • A voltage failure during the functioning of the stove causes an overheating of the boiler and it is necessary to stoke it again and start the stove. • Replace the thermostat, cod Com0238. Call a specialised technician • Clean the filter (see Maintenance) • Replace the card, cod Com0231. Call a specialised technician
<ul style="list-style-type: none"> • The stove switches off. Alarm displayed "AlAr hottemp" 	<ul style="list-style-type: none"> • Fumes feeler is faulty • Electronic card faulty • The environment exchanger fan doesn't work • Too high parameter set on card during phase 5 	<ul style="list-style-type: none"> • Replace the feeler, cod Com0239. Call a specialised technician • Replace the card, cod Com0231. Call a specialised technician • Replace the fan, cod Com0237. Call a specialised technician • Call a specialised technician to regulate the pellets stoke
<ul style="list-style-type: none"> • The stove switches off. Alarm displayed "AlAr Sond" 	<ul style="list-style-type: none"> • Fumes temperature feeler disconnected • Fumes temperature feeler is faulty 	<ul style="list-style-type: none"> • Verify the feeler is connected to the card and/or put in and blocked in the seat of the extractor. Call a specialised technician • Replace the feeler, cod Com0239. Call a specialised technician

• GUARANTEE

Fair srl guarantees the quality of manufacture and of the materials used.

The Guarantee is valid for a period of 2 years, and runs from the date of first startup as recorded on the certificate and corroborated by the Service Centre which carried out the operation, for the models for which this is specified, and for other models from the date of installation as corroborated by the personnel who installed it, provided always that not more than 24 months have passed from the date of purchase from Fair srl; if this period has been exceeded, the guarantee will have to be recognised by the seller.

The certificate must be marked by the stamp of the staff that carried out the installation.

During that period, Fair srl undertakes to repair and/or replace free of charge those parts which in its own exclusive judgement prove to be defective.

Such repairs shall not alter the date of expiry of the Guarantee.

The Guarantee does not cover:

1 - Damage caused by incorrect installation of the equipment or by unsuitability of the system.

2 - Faults resulting from negligence, lack of care, incompetent use, or repairs carried out by non-authorized third parties.

3 - Parts normally subject to wear, or which have a shorter life-span than the period of Guarantee indicated above.

For instance: strips, hearth, firebox, pyroceram, particular painted, majolica, etc.

The guarantee is valid for 24 months from the date of first startup as indicated on this certificate, which should be completed correctly and accompanied by the receipt of purchase as proof. The apparatus is not guaranteed in any way for non-domestic use.

The same applies in the event that the staff of the Technical Service Centre or of Fair srl discover while doing repairs that the date of installation/first startup is not the true one (which can be detected from identifying details and other elements in the equipment).

The present certificate must be presented to the staff of the Authorised Customer Service Centre, together with a document of proof of purchase (invoice or docket), every time the client ask for an intervention during the guarantee period.

Fair srl will not be liable for loss or damage caused to persons or things resulting from breakdown, forced suspension of use of the equipment or improper use.

The Guarantee is valid only on the following conditions:

1 - The equipment must be installed by qualified personnel.

2 - The instalment must be done in accordance with the Laws in force in the territory and according to the directions given in the instruction manual.

3 - Any repairs must be carried out only by staff of Authorised Service Centres.

4 - The Guarantee certificate must be completed in all its parts in a clear and readable manner.

Fair srl grants no other Guarantees apart from the above.

In case of any dispute, the Court of Vicenza shall have Jurisdiction.

Technical Services-Original spare parts

Before leaving the factory, this apparatus has been tested and commissioned by expert, specialised staff, in order to achieve the best possible results in operation. Any repairs or commissioning that may become necessary must be carried out with the greatest care and attention; we therefore advise you to always refer to the dealer who sold the apparatus to you or to our nearest Technical Servicing Centre, specifying the model and serial number and describing the problem. Also bear in mind that original spare parts can be obtained only and exclusively from our Technical Servicing Centres and authorised points of sale.

PELLETS STOVE

Specialised Technical Servicing Centre

Company			
Mr/Ms.			
Street			No.
Postcode	Town		State
Tel.	Fax	Mobile	
1st IGNITION			
Model			
Serial number			
Tests carried out:			
Automatic ignition <input type="checkbox"/>		Combustion air motor <input type="checkbox"/>	
Convection air motor <input type="checkbox"/>		Appearance <input type="checkbox"/>	
Packaging <input type="checkbox"/>		Technical data label <input type="checkbox"/>	
Date of 1st ignition			
Testing technician			
Signature			

PELLETS STOVE

Specialised Technical Servicing Centre

Work done on: ___ / ___ / ___

Material used:	Guarantee	
	<input type="checkbox"/> YES	<input type="checkbox"/> NO
	<input type="checkbox"/> YES	<input type="checkbox"/> NO
	<input type="checkbox"/> YES	<input type="checkbox"/> NO
	<input type="checkbox"/> YES	<input type="checkbox"/> NO
User's signature	Signature of TSC	

Specialised Technical Servicing Centre

Work done on: ___ / ___ / ___

Material used:	Guarantee	
	<input type="checkbox"/> YES	<input type="checkbox"/> NO
	<input type="checkbox"/> YES	<input type="checkbox"/> NO
	<input type="checkbox"/> YES	<input type="checkbox"/> NO
	<input type="checkbox"/> YES	<input type="checkbox"/> NO
User's signature	Signature of TSC	

Specialised Technical Servicing Centre

Work done on: ___ / ___ / ___

Material used:	Guarantee	
	<input type="checkbox"/> YES	<input type="checkbox"/> NO
	<input type="checkbox"/> YES	<input type="checkbox"/> NO
	<input type="checkbox"/> YES	<input type="checkbox"/> NO
	<input type="checkbox"/> YES	<input type="checkbox"/> NO
User's signature	Signature of TSC	

PELLETS STOVE

Specialised Technical Servicing Centre

Work done on: ___ / ___ / ___

Material used:	Guarantee	
	<input type="checkbox"/> YES	<input type="checkbox"/> NO
	<input type="checkbox"/> YES	<input type="checkbox"/> NO
	<input type="checkbox"/> YES	<input type="checkbox"/> NO
	<input type="checkbox"/> YES	<input type="checkbox"/> NO
User's signature	Signature of TSC	

Specialised Technical Servicing Centre

Work done on: ___ / ___ / ___

Material used:	Guarantee	
	<input type="checkbox"/> YES	<input type="checkbox"/> NO
	<input type="checkbox"/> YES	<input type="checkbox"/> NO
	<input type="checkbox"/> YES	<input type="checkbox"/> NO
	<input type="checkbox"/> YES	<input type="checkbox"/> NO
User's signature	Signature of TSC	

Specialised Technical Servicing Centre

Work done on: ___ / ___ / ___

Material used:	Guarantee	
	<input type="checkbox"/> YES	<input type="checkbox"/> NO
	<input type="checkbox"/> YES	<input type="checkbox"/> NO
	<input type="checkbox"/> YES	<input type="checkbox"/> NO
	<input type="checkbox"/> YES	<input type="checkbox"/> NO
User's signature	Signature of TSC	

PELLETS STOVE



FAIR s.r.l.
Via Lago di Costanza, 24 - 36015 Schio - VI - ITALIA
Tel. 0445 698000 - Fax 0445 698100
e-mail: info@fair-europe.com - <http://www.fair-europe.com>
