

DAIKIN



OPERATION MANUAL

Split System air conditioners

**FHB35FK7V1
FHB45FK7V1
FHB60FK7V1**

**FHB35GZ7V1
FHB45GZ7V1**

**FHYB35GZ7V1
FHYB45GZ7V1**

**FHYB35FK7V1 FHYBP35B7V1
FHYB45FK7V1 FHYBP45B7V1
FHYB60FK7V1 FHYBP60B7V1
FHYB71FK7V1 FHYBP71B7V1
FHYB100FK7V1 FHYBP100B7V1
FHYB125FK7V1 FHYBP125B7V1**

**FHC35B7V1 FHC35BZ7V1
FHC45B7V1 FHC45BZ7V1
FHC60B7V1 FHC60BZ7V1**

**FHYC35B7V1 FHYC35BZ7V1
FHYC45B7V1 FHYC45BZ7V1
FHYC60B7V1
FHYC71B7V1 FHYCP35B7V1
FHYC100B7V1 FHYCP45B7V1
FHYC125B7V1 FHYCP60B7V1
FHYCP71B7V1
FHYCP100B7V1
FHYCP125B7V1**

**FDY125B7V1 FDYP125B7V1
FDY200B7V1 FDYP200B7V1
FDY250B7V1 FDYP250B7V1**

Operation manual
Split System air conditioners

English

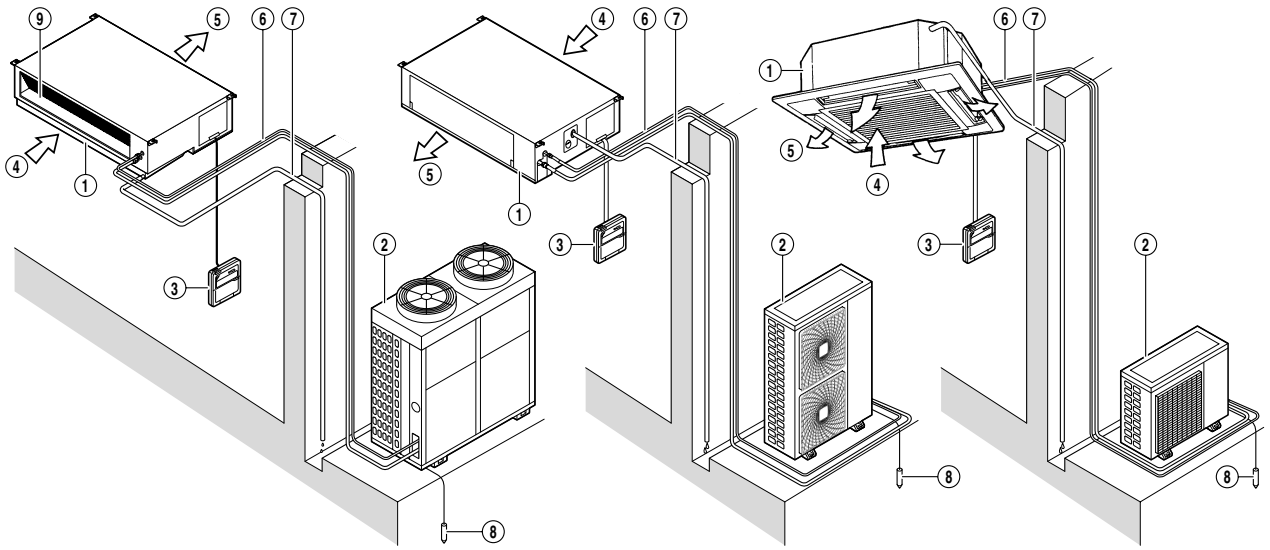

1

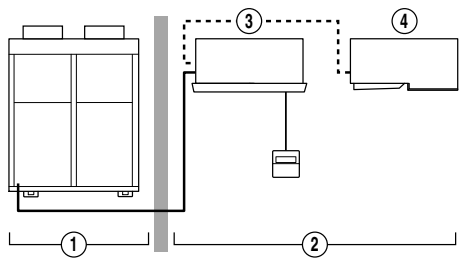

2

❄️	🏠		🏠 R22	🏠 R407C
	°CDB	°CWB	°C	°C
R35-45-60	18 - 33	12 - 24	≤80%	-15 ~ 46
R(P)71-100-125	18 - 35	14 - 25		
R(P)200-250	18 - 35	14 - 24	-5 ~ 46	-5 ~ 43
RY35-45-60	18 - 33	12 - 24	≤80%	-5 ~ 46
RY(P)71-100-125	18 - 35	12 - 25		
RY200-250	18 - 35	14 - 28	0 ~ 46	-5 ~ 43

☀️	🏠		🏠
	°CDB	°CWB	°C
RY35-45-60	15 - 27	-9 ~ 21	-10 ~ 15.5
RY(P)71-100-125	15 - 24	-9 ~ 21	-10 ~ 15.5
RY(P)200-250		-10 ~ 15.5	

4

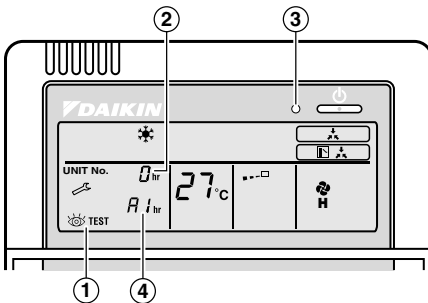

7

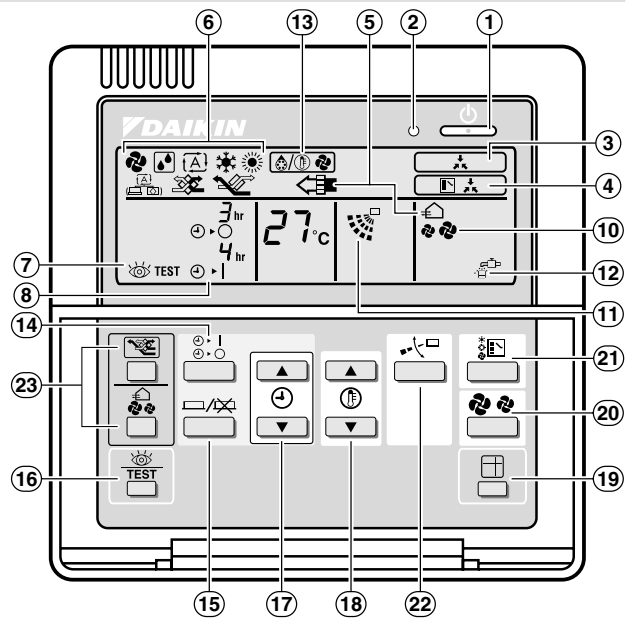

3

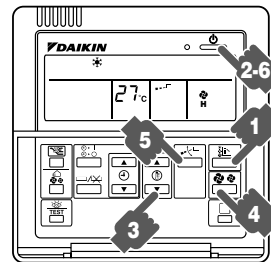

5

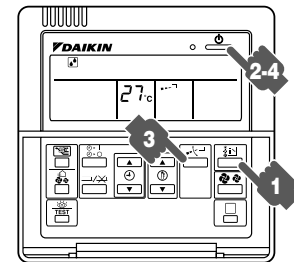

6

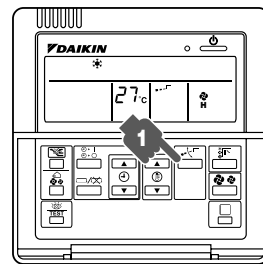

8

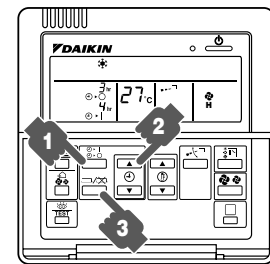

9

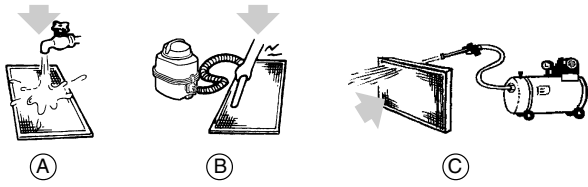

10

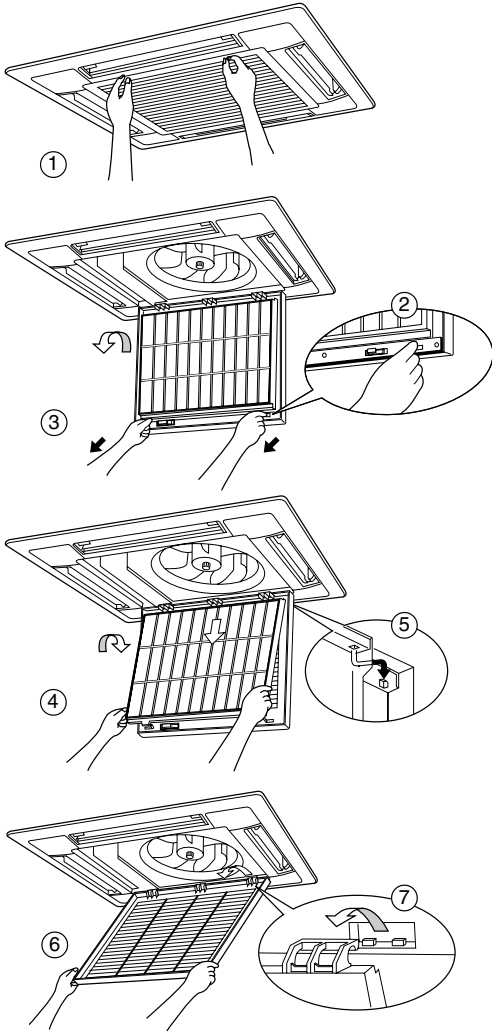

11

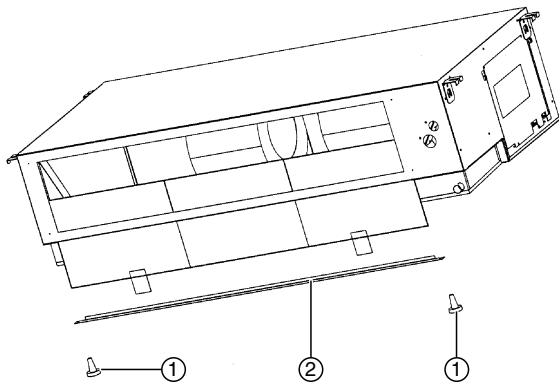

13

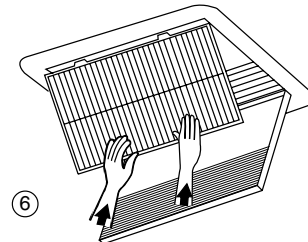
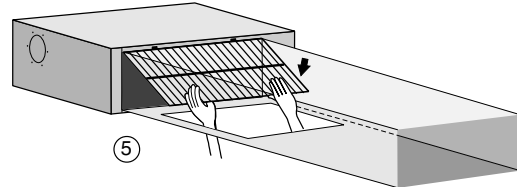
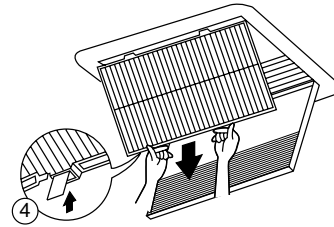
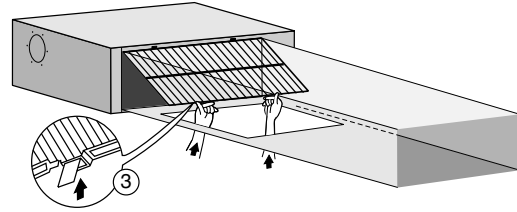
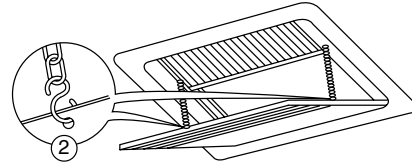
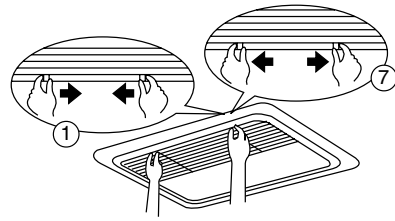

12

	page
What to do before operation	1
Names and functions of parts	1
Name and function of each switch and display on the remote controller	1
Operation range	2
Installation site	2
Operation procedure	2
Optimum operation	4
Not a malfunction of the air conditioner	4
Trouble shooting	5
Maintenance	5
Disposal requirements	6



THANK YOU FOR PURCHASING THIS DAIKIN AIR CONDITIONER.
 CAREFULLY READ THIS OPERATION MANUAL BEFORE USING THE AIR
 CONDITIONER. IT WILL TELL YOU HOW TO USE THE UNIT PROPERLY AND HELP
 YOU IF ANY TROUBLE OCCURS.
 AFTER READING THE MANUAL, FILE IT FOR FUTURE REFERENCE

WHAT TO DO BEFORE OPERATION (REFER TO FIG. 2)

This operation manual is for the following systems with standard control. Before initiating operation, contact your Daikin dealer for the operation manual that corresponds to your system.

If your installation has a customized control system, ask your Daikin dealer for the operation that corresponds to your system.

1. Outdoor unit
2. Indoor unit
3. Unit with remote controller
4. Unit without remote controller (When used as simultaneous operation)
 - Heat pump type.
This system provides cooling, heating, automatic, and fan operation modes.
 - Straight cooling type.
This system provides cooling, and fan operation modes.

NAMES AND FUNCTIONS OF PARTS (REFER TO FIG. 1)

1. Indoor unit.
2. Outdoor unit.
3. Remote controller.
4. Inlet air.
5. Discharged air.
6. Refrigerant piping, connection electric wire.
7. Drain pipe.
8. Ground wire.
Wire to ground outdoor unit to prevent electrical shocks.
9. Airfilter.

NAME AND FUNCTION OF EACH SWITCH AND

DISPLAY ON THE REMOTE CONTROLLER (REFER TO FIG. 3)

1. ON/OFF BUTTON.
Press the button and the system will start.
Press the button again and the system will stop.
2. OPERATION LAMP (RED).
The lamp lights up during operation.

3. DISPLAY "" (UNDER CENTRALIZED CONTROL).
When this display shows, the system is UNDER CENTRALIZED CONTROL. (This is not a standard specification.)
4. DISPLAY "" (CHANGEOVER UNDER CONTROL).
This display shows when the outdoor unit is individual operation system.
5. DISPLAY "" (VENTILATION/AIR CLEANING)
This display shows that the total heat exchange and the air cleaning unit are in operation. These are optional accessories.
6. DISPLAY "" (OPERATION MODE)
This display shows the current OPERATION MODE. For straight cooling type, "" (Auto) and "" (Heating) are not installed.
7. DISPLAY "" (INSPECTION/TEST OPERATION)
When the INSPECTION/TEST OPERATION BUTTON is pressed, the display shows the system mode is in.
8. DISPLAY "" (PROGRAMMED TIME)
This display shows PROGRAMMED TIME of the system start or stop.
9. DISPLAY "" (SET TEMPERATURE)
This display shows the set temperature.
10. DISPLAY "" (FAN SPEED)
This display shows the set fan speed.
11. DISPLAY "" (AIR FLOW FLAP)
Refer to page 3.
12. DISPLAY "" (TIME TO CLEAN AIR FILTER)
Refer to page 5.
13. DISPLAY "" (DEFROST)
Refer to page 3.
14. TIMER MODE START/STOP BUTTON
Refer to page 3.
15. TIMER ON/OFF BUTTON
Refer to page 3.
16. INSPECTION/TEST OPERATION BUTTON
This button is used only by qualified service persons for maintenance purposes.
17. PROGRAMMING TIME BUTTON
Use this button for programming "START and/or STOP" time.
18. TEMPERATURE SETTING BUTTON
Use this button for SETTING TEMPERATURE.
19. FILTER SIGN RESET BUTTON
Refer to page 5.
20. FAN SPEED CONTROL BUTTON
Press this button to select the fan speed, HIGH or LOW, of your choice.
21. OPERATION MODE SELECTOR BUTTON
Press this button to select OPERATION MODE.
22. AIR FLOW DIRECTION ADJUST BUTTON
Refer to page 3.
23. NOT APPLICABLE

NOTE For the sake of explanation, all indications are shown on the display in Figure 3 contrary to actual running situations.



Warning

- Never let the indoor unit and the remote controller get wet. It may cause an electric shock or a fire.
- Never use flammable spray such as hair spray, lacquer or paint near the unit. It may cause a fire.
- Never replace a fuse with that of a wrong ampere rating or other wires when the fuse blows out. Use of wire or copper wire may cause the unit to break down or cause a fire.
- Never touch the air outlet or the horizontal blades while the swing flap is in operation. Fingers may become caught or the unit may break down.
- Never insert objects such as sticks into the air inlet or outlet. It is dangerous for an object to touch the fan when it is turning at high speed.
- Never remove the fan guard of the outdoor unit. The rotating fan at high speed without the guard is very dangerous.
- Never press the button of the remote controller with a hard, pointed object. The remote controller may be damaged.
- Never pull or twist the electric wire of a remote controller. It may cause the unit to malfunction.
- Never inspect or service the unit by yourself. Ask a qualified service person to perform this work.

OPERATION RANGE (REFER TO FIG. 4)

If operating outside the following conditions, safety devices may activate, rendering the air conditioner inoperable or may cause the indoor unit to sweat.

The setting temperature range of the remote controller is 16°C - 32°C.

(DB = dry bulb, WB = wet bulb, ❄️ = cooling, ☀️ = heating, 🏠 = indoor, 🏡 = outdoor, °C = temperature, 💧 = humidity)

INSTALLATION SITE

Warning

- Never place anything under the indoor unit that you don't want to get wet. The unit may sweat when the humidity is over 80% or when the drain outlet is clogged.
- Never place other heating equipment directly beneath the indoor unit. Subject to deformation caused by heat.
- Do not place TV, radio, stereo, etc. within 1 meter from the indoor unit and remote controller. Doing so may cause interference in the picture or sound.

OPERATION PROCEDURE

Warning

- If a function that is not available is selected, the message NOT AVAILABLE will appear.
- Operating procedure varies with heat pump type and straight cooling type. Contact your Daikin dealer to confirm your system type.
- To protect the unit, turn on the main power switch 6 hours before operation.
- If the main power supply is turned off during operation, operation will restart automatically after the power turns back on again.

COOLING, HEATING, AUTOMATIC, AND FAN OPERATION

(REFER TO FIG. 5)

- 1 Press OPERATION MODE SELECTOR button several times and select the OPERATION MODE of your choice as follows.

COOLING OPERATION 

HEATING OPERATION 

AUTOMATIC OPERATION 

FAN OPERATION 

- For straight cooling type, you can select "cooling" and "fan" operation.

AUTOMATIC OPERATION

In this operation mode, COOL/HEAT changeover is automatically conducted.

- 2 Press ON/OFF button.

OPERATION lamp lights up and the system starts OPERATION.

Adjustment

For programming TEMPERATURE, FAN SPEED and AIR FLOW DIRECTION, follow the procedure shown below.

- 3 Press TEMPERATURE SETTING button and program the setting temperature.

 Each time this button is pressed, setting temperature rises 1°C.

 Each time this button is pressed, setting temperature lowers 1°C.

- The setting is impossible for fan operation.

Note

Set the temperature within the ranges mentioned under "OPERATION RANGE".

- 4 Press FAN SPEED CONTROL button.

High or Low fan speed can be selected. (FH(Y)C and FH(Y)B only)

- 5 Press AIR FLOW DIRECTION ADJUST button.

Refer to "ADJUSTING THE AIR FLOW DIRECTION" for details. (FH(Y)C only)

Stopping the system

- 6 Press ON/OFF button once again.

OPERATION lamp goes off, and the system stops OPERATION.

EXPLANATION OF HEATING OPERATION

Defrost operation

- As the frost on the coil of an outdoor unit increases, heating effect decreases and the system goes into DEFROST OPERATION.
- The indoor unit fan stops and the remote controller display shows "❄️/❄️/❄️".
- After 6 to 8 minutes (maximum 10 minutes) of DEFROST OPERATION, the system returns to HEATING OPERATION.

PROGRAM DRY OPERATION (FIG. 6) (FOR FH(Y)B AND FH(Y)C ONLY)

- The function of this program is to decrease the humidity in your room with the minimum temperature decrease.
- Micro computer automatically determines TEMPERATURE and FAN SPEED.
- This system does not go into operation if the room temperature is below 16°C.

1 Press OPERATION MODE SELECTOR button several times and select "☉" (PROGRAM DRY OPERATION).

2 Press ON/OFF button.

OPERATION lamp lights up and the system starts OPERATION.

Adjustment

3 Press AIR FLOW DIRECTION ADJUST button.

Refer to "ADJUSTING THE AIR FLOW DIRECTION" for details.

Stopping the system

4 Press ON/OFF button again.

OPERATION lamp goes off and the system stops OPERATION.

ADJUSTING THE AIR FLOW DIRECTION (FIG. 8) (FOR FH(Y)C ONLY)

Press the AIR FLOW DIRECTION button to adjust the air flow angle.

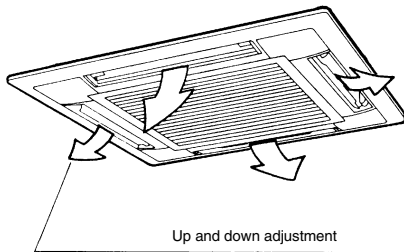

- The movable limit of the blade is changeable. Contact your Daikin dealer for details.

1 Press the AIR FLOW DIRECTION ADJUST button to select the air direction as shown below.

The AIR FLOW FLAP display swings as shown below and the air flow direction continuously varies. (Automatic swing setting)

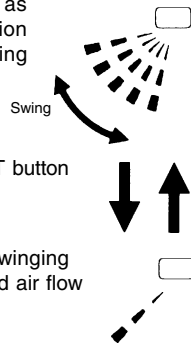

Press AIR FLOW DIRECTION ADJUST button to select the air direction of your choice.

The AIR FLOW FLAP display stops swinging and the air flow direction is fixed. (Fixed air flow direction setting)

MOVEMENT OF THE AIR FLOW FLAP

For the following conditions, micro computer controls the air flow direction so it may be different from the display.

Operation mode	Cooling	Heating
Operation conditions	<ul style="list-style-type: none"> • When room temperature is lower than the set temperature 	<ul style="list-style-type: none"> • When room temperature is higher than the set temperature • At defrost operation
	<ul style="list-style-type: none"> • When operating continuously at horizontal air flow direction 	

Operation mode includes automatic operation.

PROGRAM TIMER OPERATION (FIG. 9)

- The timer is operated in the following two ways.

Programming the stop time ("⌚ ▶ ○") ... The system stops operating after the set time has elapsed.

Programming the start time ("⌚ ▶ |") ... The system starts operating after the set time has elapsed.

- The timer can be programmed a maximum of 72 hours.
- The start and the stop time can be simultaneously programmed.

1 Press the TIMER MODE START/STOP button several times and select the mode on the display.

The display flashes.

For setting the timer stop ... "⌚ ▶ ○".

For setting the timer start ... "⌚ ▶ |".

2 Press the PROGRAMMING TIME button and set the time for stopping or starting the system.

▲ When this button is pressed, the time advances by 1 hour.



⌚ When this button is pressed, the time goes backward by 1 hour.



3 Press the TIMER ON/OFF button.

The timer setting procedure ends.

The display "⌚ ▶ ○" or "⌚ ▶ |" changes from flashing light to a constant light.

NOTE:

- When setting the timer Off and On at the same time, repeat the above procedure from 1. to 3. once again.

For example:

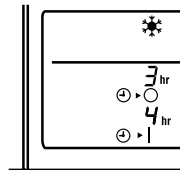

When the timer is programmed to stop the system after 3 hours and start the system after 4 hours, the system will stop after 3 hours and then 1 hour later the system will start.

- After the timer is programmed, the display shows the remaining time.
- Press the TIMER ON/OFF button once again to cancel programming. The display vanishes.

PRECAUTIONS FOR GROUP CONTROL SYSTEM OR TWO REMOTE CONTROLLER CONTROL SYSTEM

This system provides two other control systems beside individual control (one remote controller controls one indoor unit) system. Confirm the following if your unit is of the following control system type.

- Group control system.
One remote controller controls up to 16 indoor units. All indoor units are equally set.
- Two remote controller control system.
Two remote controllers control one indoor unit (In case of group control system, one group of indoor units). The unit is individually operated.

Note

Contact your Daikin dealer in case of changing the combination or setting of group control and two remote controller control systems.

OPTIMUM OPERATION

Observe the following precautions to ensure the system operates properly.

- Adjust the air outlet properly and avoid direct air flow to room inhabitants.
- Adjust the room temperature properly for a comfortable environment. Avoid excessive heating or cooling.
- Prevent direct sunlight from entering a room during cooling operation by using curtains or blinds.
- Keep doors and windows closed. If the doors and windows remain open, room air will flow out and decrease the effect of cooling and heating.
- Never place objects near the air inlet and the air outlet of the unit. It may retard effectiveness or cause operation to stop.
- Turn off the main power supply switch when not using for long periods of time. Electricity is consumed as long as the switch is on. Turn off the main power supply switch in order to save energy. Turn on the main power supply switch 6 hours before restarting operation in order to ensure smooth operation. (Refer to "MAINTENANCE")
- When the display shows "  " (TIME TO CLEAN AIR FILTER), have a qualified service person to clean the filters. (Refer to "MAINTENANCE")

NOT A MALFUNCTION OF THE AIR CONDITIONER

The following symptoms do not indicate air conditioner malfunction.

THE SYSTEM DOES NOT OPERATE

- The system does not restart immediately after the ON/OFF button is pressed.
If the OPERATION lamp lights, the system is in its normal operating condition.
It does not restart immediately because one of its safety devices actuates to prevent the system from being overloaded. The system will turn on again automatically after three minutes.
- The system does not restart immediately when the TEMPERATURE SETTING button is returned to its former position after pushing.
It does not restart immediately because one of its safety devices actuates to prevent the system from being overloaded. The system will turn on again automatically after three minutes.
- The system does not start when the display shows "  " (UNDER CENTRALIZED CONTROL) and it flashes for a few seconds after pressing an operation button.
This is because the system is under centralized control. When the display flashes, it indicates that the system cannot be controlled by the indoor unit.

- The system does not start immediately after the power supply is turned on.
Wait one minute until the micro computer is prepared for operation.

WHITE MIST COMES OUT OF A UNIT

- When humidity is high during cooling operation (In oily or dusty places).
If the inside of an indoor unit is extremely contaminated, the temperature distribution inside a room becomes uneven. It is necessary to clean the inside of the indoor unit. Ask your Daikin dealer for details on cleaning the unit. This operation requires a qualified service person.
- When the system is changed over to HEATING OPERATION after DEFROST OPERATION.
Moisture generated by DEFROST becomes steam and exits.

NOISE OF AIR CONDITIONERS

- A continuous low "hissing" sound is heard when the system is in COOLING or DEFROST OPERATION.
This is the sound of refrigerant gas flowing through both indoor and outdoor units.
- A "hissing" sound which is heard at the start or immediately after the stop of operation or which is heard at the start or immediately after the stop of DEFROST OPERATION.
This is the noise of refrigerant caused by flow stop and flow change.
- A continuous low "swishing" sound is heard when the system is in COOLING OPERATION or at a stop.
The noise is heard when the drain pump is in operation.
- A "squeaking" sound is heard when the system is in operation or after the stop of operation.
Expansion and contraction of plastic parts caused by temperature change makes this noise.

DUST FROM THE UNITS

- Dust may blow out from the unit after starting operation from long resting time. Dust absorbed by the unit blows out.

THE UNITS GIVE OFF ODOURS

- The unit absorbs the smell of rooms, furniture, cigarettes, etc., and then emits them.

THE LIQUID CRYSTAL DISPLAY OF THE REMOTE CONTROLLER SHOWS "BB"

- Happens immediately after the main power supply switch is turned on.
Shows that the remote controller is in normal condition. Continues temporary.

TROUBLE SHOOTING

If one of the following malfunctions occurs, take the measures shown below and contact your Daikin dealer.

The system must be repaired by a qualified service person.

- If a safety device such as a fuse, a breaker, or an earth leakage breaker frequently actuates, or ON/OFF switch does not properly work.
Measure: Turn off the main power switch.
- If water leaks from unit.
Measure: Stop the operation.
- If the display “” (INSPECTION) (1), “UNIT No.” (2), and the OPERATION lamp (3) flashes and the “MALFUNCTION CODE” (4) appears. Refer to Fig. 7.
Measure: Notify your Daikin dealer and inform him/her of the display.

If the system does not operate properly, except for the above mentioned case, and none of the above mentioned malfunctions is evident, investigate the system according to the following procedures.

If the system does not operate at all.

- Check if there is a power failure.
Wait until power is restored. If power failure occurs during operation, the system automatically restarts immediately after the power supply recovers.
- Check if the fuse has blown or breaker has been tripped.
Change the fuse or set the breaker.

If the system stops operating after operation is complete.

- Check if the air inlet or outlet of outdoor or indoor unit is blocked by obstacles.
Remove the obstacle and make it well-ventilated.
- Check if the air filter is clogged.
Have a qualified service person clean the air filters.

The system operates but it does not sufficiently cool or heat.

- If the air inlet or outlet of the indoor or the outdoor unit is blocked with obstacles.
Remove the obstacle and make it well-ventilated.
- If the air filter is clogged.
Ask a qualified service person to clean the air filter.
- If the set temperature is not proper. (Refer to “OPERATION PROCEDURE, Automatic operation”)
- If the FAN SPEED CONTROL button is set to LOW SPEED. (Refer to “OPERATION PROCEDURE, Automatic operation”)
- If the air flow angle is not proper. (Refer to “Operation procedure, adjust the air flow direction”.)
- If the doors or the windows are open. Shut doors or windows to prevent wind from coming in.
- If direct sunlight enters the room (when cooling).
Use curtains or blinds.
- When there are too many inhabitants in the room. Cooling effect decreases if heat gain of the room is too large.
- If the heat source of the room is excessive (when cooling).
Cooling effect decreases if heat gain of the room is too large.

MAINTENANCE

Important

- Only a qualified service person is allowed to perform maintenance.
- Before obtaining access to terminal devices, all power supply circuits must be interrupted.
- Do not use water or air of 50°C or higher for cleaning air filters and outside panels.
- When cleaning the heat exchanger, be sure to remove the switchbox, fan motor and drain pump. Water or detergent may deteriorate the insulation of electronic components and result in burn-out of these components.

HOW TO CLEAN THE AIR FILTER

Clean the air filter when the display shows “” (TIME TO CLEAN AIR FILTER).

Increase the frequency of cleaning if the unit is installed in a room where the air is extremely contaminated.

(As a yardstick for yourself, consider cleaning the filter once a half year.)

If the dirt becomes impossible to clean, change the air filter. (Air filter for exchange is optional.)

For **FHYC-units** (Refer to figure 11)

1. Open the suction grill.
Push both knobs simultaneously and carefully lower the grille. (Identical procedure for closing.)
2. Remove the air filters
Pull the air filter clips toward you(2), and detach the filter (3).
3. Clean the air filter. (Refer to figure) 10.  air flow direction over filter.)
Use vacuum cleaner (B) or wash the air filter with water (A).
When the air filter is very dirty, use soft brush and neutral detergent.
4. Remove water and dry in the shade.
5. Fix the air filter.
Attach the air filter to the suction grill by hanging it to the projected portion above the suction grill (4).
Press the bottom of the air filter against the projections on the bottom of the grille to snap the air filter into its place (5).
6. Shut the air inlet grille (1).
Refer to item No. 1.
7. After turning on the power, press the FILTER SIGN RESET button.
The “TIME TO CLEAN AIR FILTER” display vanishes.

For **FHYB-units** (Refer to figure 12)

1. Open the suction grille. (Only for bottom suction.)
Slide both knobs simultaneously as shown and then pull them downward (1).
If chains are present, unhook the chains (2).
2. Remove the air filters.
Remove the air filters by pulling its cloth upward (rear suction(3)) or backward (bottom suction(4)).
3. Clean the air filter. (Refer to figure 10.  air flow direction over filter.)
Use vacuum cleaner (B) or wash the air filter with water (A).
When the air filter is very dirty, use soft brush and neutral detergent.
Remove water and dry in the shade.

4. Fix the air filter.
Align the two hanger brackets and push the two clips in their place (pull the cloth if necessary, rear (5), bottom suction(6)).
Confirm that four hangers are fixed.
5. Shut the air inlet grille. (Only for bottom suction.(7))
6. After turning on the power, press FILTER SIGN RESET button.
The "TIME TO CLEAN AIR FILTER" display is turned off.

For FDY-units (Refer to figure 13)

1. Remove the screws from the bottom of the filter frame and remove the filter frame downwards.
2. Clean the air filter. (Refer to figure 10.  air flow direction over filter.)
Use compressed air (C) for blowing dust particles of the filter. When the air filter is very dirty, use soft brush and neutral detergent or wash with hot (30-40°C) water if needed (B). Do not rub or wring.
3. Remove water and dry in the shade.
4. Fix the air filter. Put the air filter frame back in its position and fix firmly with the screws.

How to clean the suction grille (for FH(Y)C only, refer to figure 11)

1. Open the suction grill.
Push both knobs simultaneously and carefully lower the grille (1). (Identical procedure for closing.)
2. Detach the suction grill
Open the suction grill 45 degrees (6) and lift it upward (7).
3. Detach the air filter.
Refer to "HOW TO CLEAN THE AIR FILTER".
4. Clean the suction grille.
Wash with a soft bristle brush and neutral detergent or water, and dry thoroughly.

NOTE 

- When the suction grill is very dirty, use a typical kitchen cleaner and let it sit for about 10 minutes. Then, wash it with water.
5. Reattach the suction grill (7)(6)
See item n° 2.
 6. Close the suction grill (1)
See item n° 1.

HOW TO CLEAN AIR OUTLET AND OUTSIDE PANELS

- Clean with soft cloth.
- When it is difficult to remove stains, use water or neutral detergent.
- When the blade is extremely contaminated, remove it as below and clean or exchange it. (for FH(Y)C only)
(Blade for exchange is optional.)

NOTE:

- Do not use gasoline, benzene, thinner, polishing powder, liquid insecticide. It may cause discoloring or warping.
- Do not let the indoor unit get wet. It may cause an electric shock or a fire.

START-UP AFTER A LONG STOP

Confirm the following.

- Check that the air inlet and outlet are not blocked.
Remove any obstacle.
- Check if the earth is connected.

Clean the air filter and outside panels.

- After cleaning the air filter, make sure to attach it.

Turn on the main power supply switch.

- The control panel display lights when the power is turned on.
- To protect the unit, turn on the main power switch at least 6 hours before operation.

WHAT TO DO WHEN STOPPING THE SYSTEM FOR A LONG PERIOD

Turn on FAN OPERATION for a half day and dry the unit.

- Refer to "OPERATION PROCEDURE, Fan operation".

Cut off the power supply.

- When the main power switch is turned on, some wattage is being consumed even if the system is not operating.
- The remote controller display is turned off when the main power switch is turned off.

DISPOSAL REQUIREMENTS

Dismantling of the unit, treatment of the refrigerant, oil and eventual other parts, should be done in accordance with the relevant local and national regulations.

DAIKIN EUROPE NV

Zandvoordestraat 300, B-8400 Oostende, Belgium

4PW10622-1