

Step 1

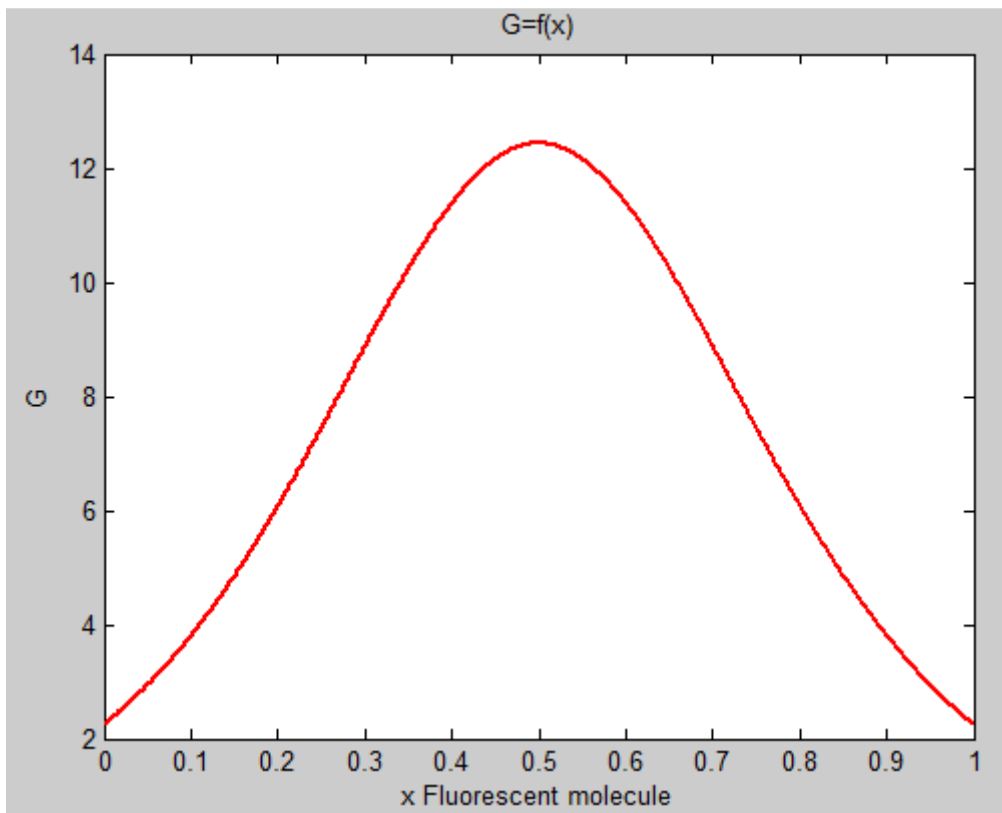

Step 2

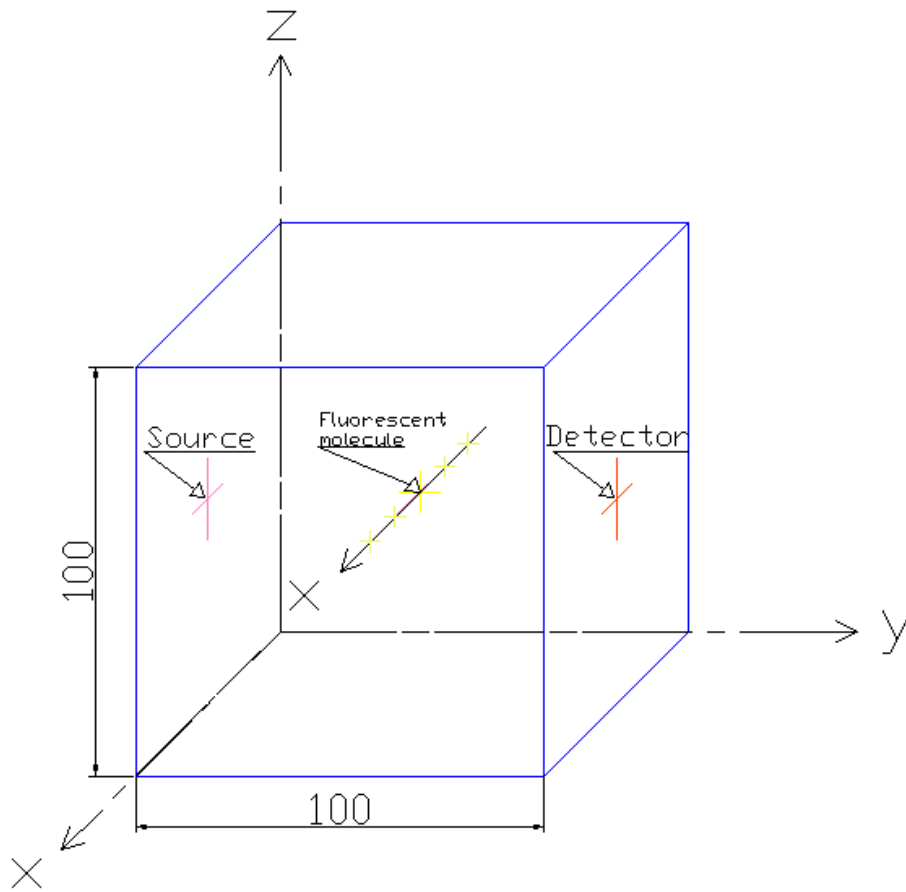
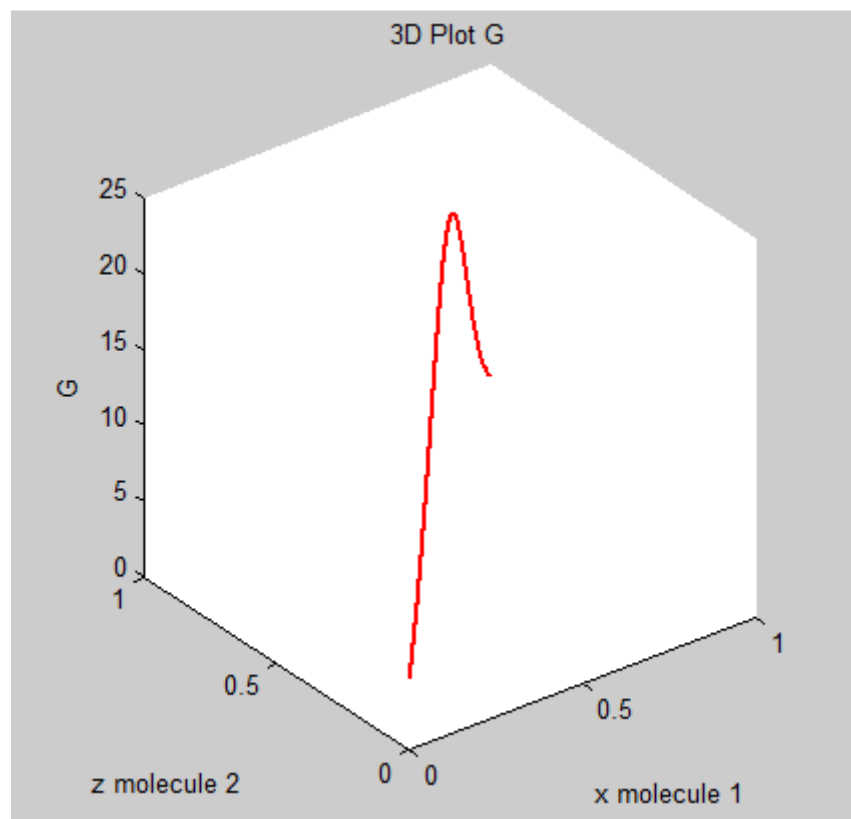
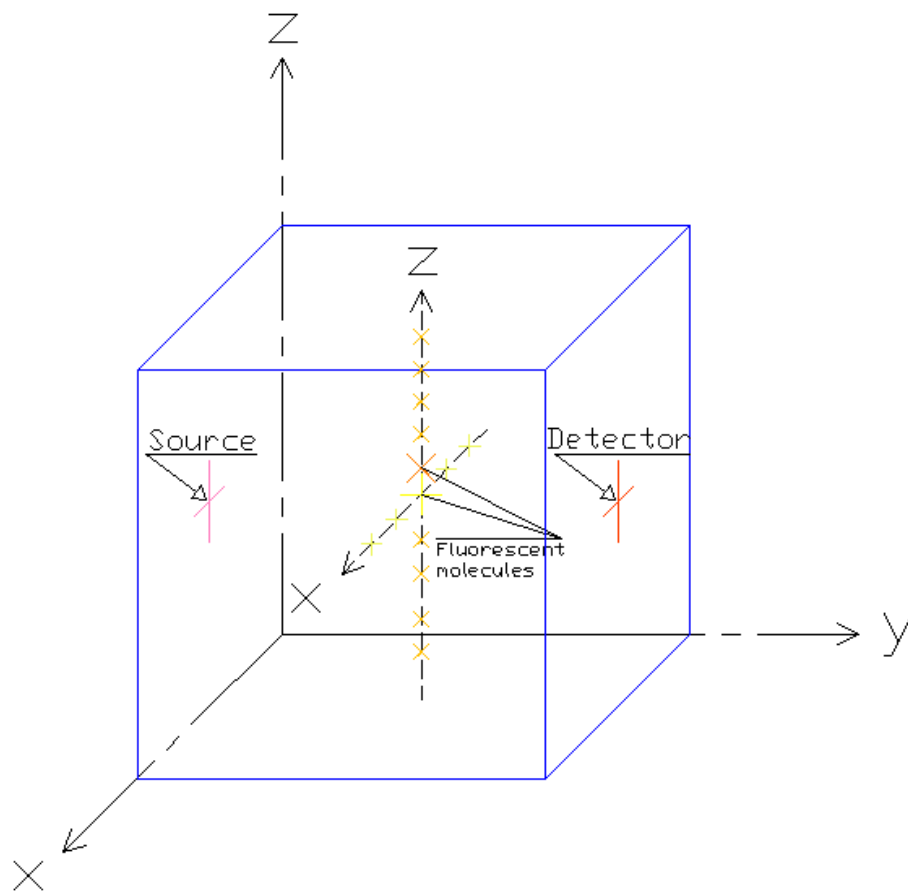

Step 3

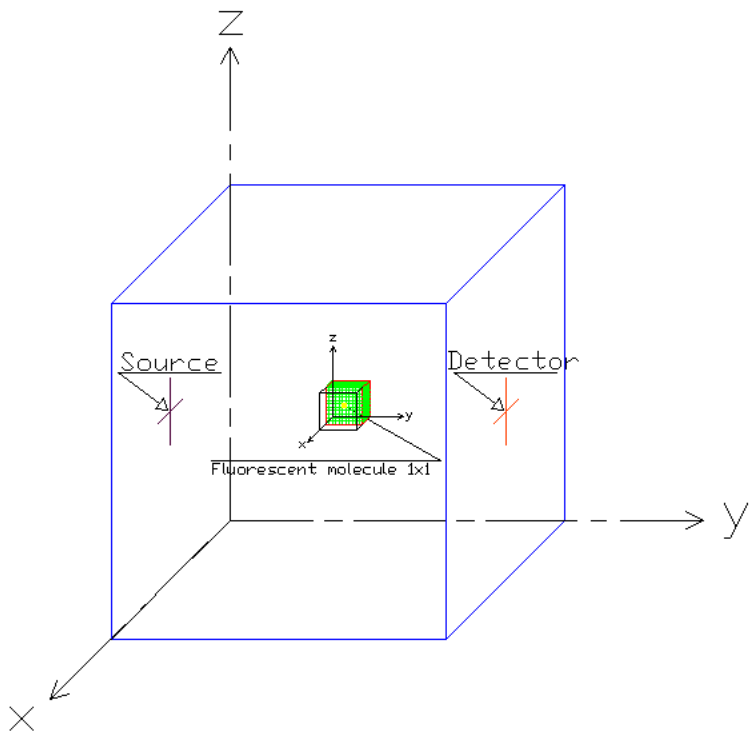
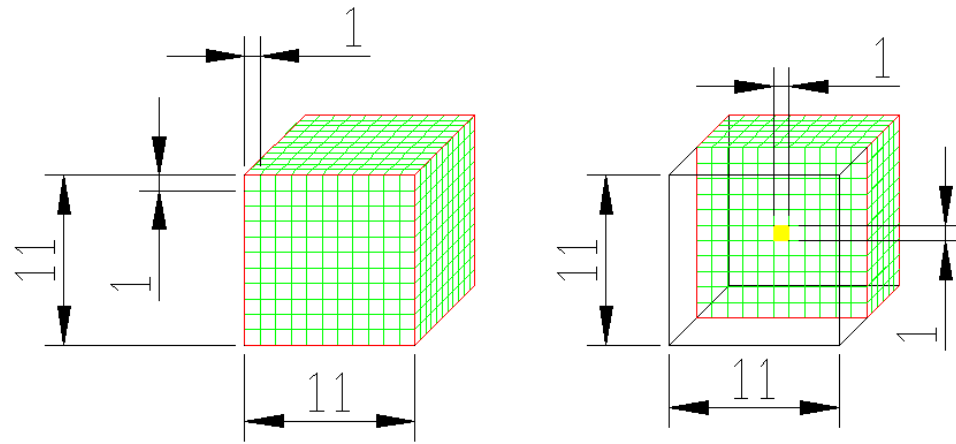

Par la suite, l'objectif est que je calcule la distance de chaque cube par rapport à la source. Pour l'instant le cube est fixe et la source également.