



NTT

**CENTRIFUGAL PUMPS TO EN733 (DIN 24255)
FOR HEAT TRANSFER OILS UP TO 350 °C**





WE HAVE ALL THE TICKS

- FOUNDED IN 1932**
- LEADING PROVIDER OF TOP QUALITY PRODUCTS**
- LOCAL MANUFACTURE**
- ACCREDITED PUMP REPAIR/SERVICE WORKSHOP**
- TAILOR MADE PUMPING SOLUTIONS**
- STATE OF ART TRAINING CENTRE**
- CBS: QUALITY MANAGEMENT SYSTEM**
- BEE ACCREDITED**
- DEEP APPLICATION KNOWLEDGE**



Version 1 - NTT: Rapid Allweiler Pumps

Whilst all care has been taken to ensure the accuracy of the information contained in this brochure was correct at the time of printing, please be advised we cannot be held responsible for any errors contained within and or changes that may have taken place. Dimensions contained within are for reference purpose only and should not be used for construction; certified drawings are available upon request. For confirmation of any information contained herewith please contact a member of our technical sales team.

COLFAX
Fluid Handling

ALLWEILER 

APPLICATION

- Chemical and Pharmaceutical Industry
- Mineral Oil
- Food, Laundries and Textile
- Leather and Paper
- Wood Manufacturing
- Paint and Lacquer
- Building, Tar and Bitumen
- Electrical Engineering Industries



NTT

NIT (In-line option)

RA Pump Range	Minimum Flow (m ³ /h)	Maximum Flow (m ³ /h)	Minimum Head (m)	Maximum Head (m)	Maximum Temperature
NTT / NIT	3	530	3	97	350°C

DESIGN & CONSTRUCTION

- Thermal oil pumps capable of handling temperatures up to 350°C in heat transfer plants without the necessity for external cooling of the pump.
- The fluids pumped must have lubricating properties and should not contain any solids or abrasive particles, as the non drive end bearing and mechanical seal is lubricated by the pumped liquid.
- The unique heat dissipation design of the bearing housing ensures a reduced temperature at the mechanical seal faces and the bearings. See page 2.
- Back pull out for ease of maintenance.
- These pumps are further equipped with a safety stuffing box and throttling area in front of the mechanical seal. In case of a seal failure this prevents the pumped liquid from emerging in a hazardous quantity or manner. With drain connection adequate piped up, the safety requirements of DIN 4754 are exceeded. (The pumps have a drain connection to ensure that any seepage past the shaft sealing can be safely drained through this connection).
- High temperature bearings are fitted where applicable.

Flanges

- Pump flanges according to PN 16 EN 1092-1 (BS 4504) .

Motors

- No special motor or coupling guard required due to unique heat dissipation design.







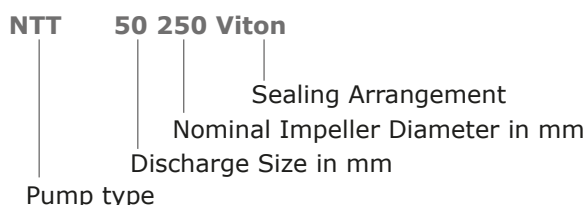





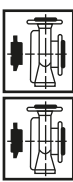













MATERIALS OF CONSTRUCTION

Volute Casing:	S.G. Iron Grade 42 (Ductile Iron)
Casing Cover:	S.G. Iron Grade 42 (Ductile Iron)
Matching Ring:	S.G. Iron Grade 42 (Ductile Iron)
Impeller:	GG20 Cast iron
Bearing Housing:	GG20 Cast iron
Shaft:	Grade 431 Stainless steel

MODEL DESCRIPTION



INTERCHANGEABILITY DIAGRAM

Bearing Bracket Size	Bearing Bracket	Shaft unit	Casing Cover	Volute - Nominal Impeller Diameter			Delivery Flange
				250	200	160	ID
360	NTT 		NTT360 	 with adaptor ring 250	     	    	25 32 40 50 65 80
470	NTT 		NTT470 	   	 	   	65 80 100 125

Maximum Working Pressure

The maximum total working pressure at various temperatures is indicated in the graph below.

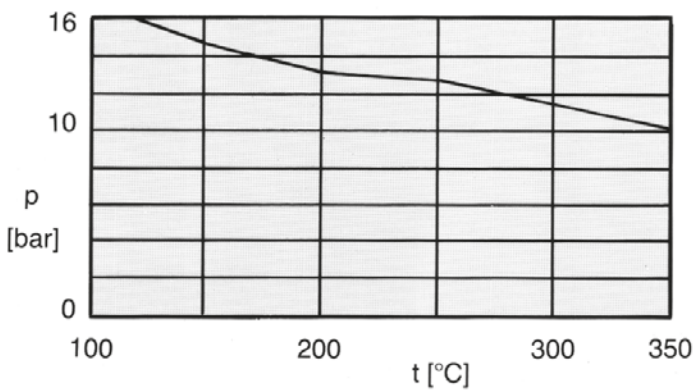

Heat Dissipation

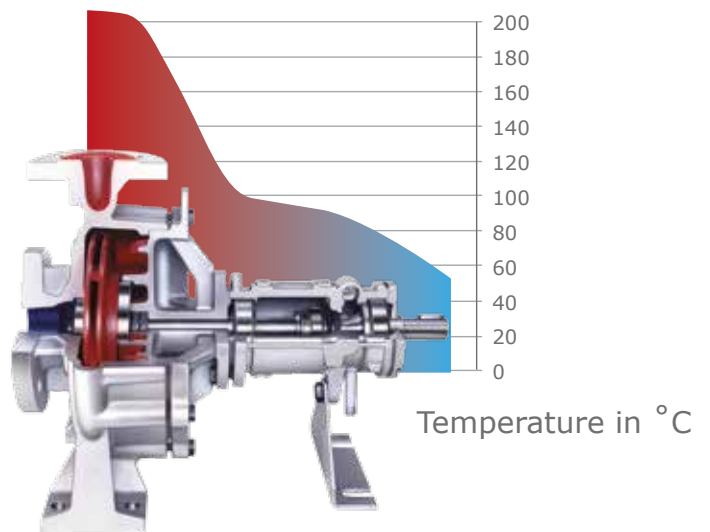

SECTIONAL DRAWING

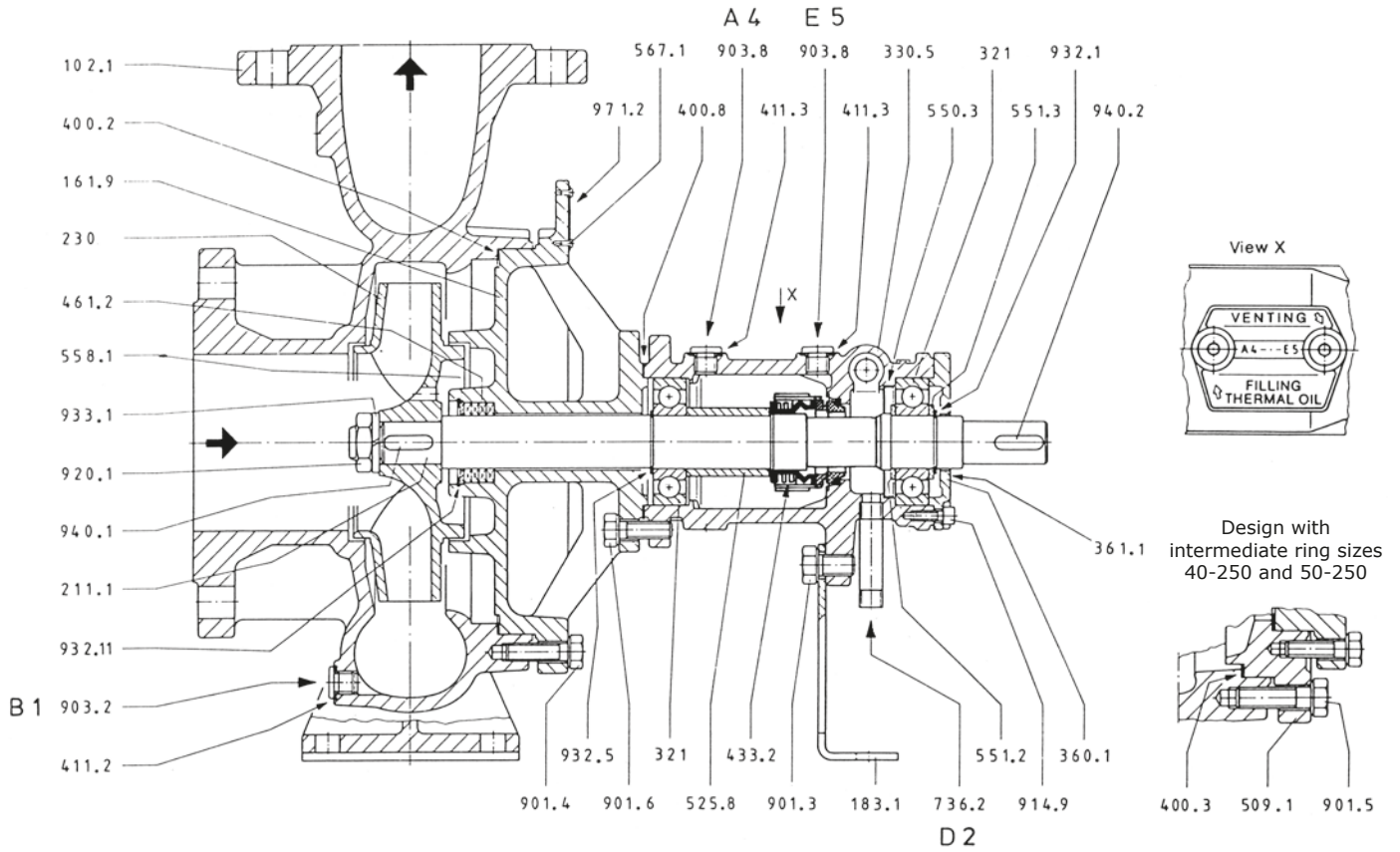

PARTS LIST

DESCRIPTION	PART NO.
VOLUTE CASING	102.1
CASING COVER	161.9
SUPPORT FOOT	183.1
SHAFT	211.1
IMPELLER	230
GROOVED BALL BEARING	321
BEARING BRACKET	330.5
BEARING COVER	360.1
LIP SEAL	361.1
GASKET	400.2
GASKET	400.3
BEARING HOUSING GASKET	400.8
WASHER	411.2
WASHER	411.3
MECHANICAL SEAL	433.2
PACKING RINGS	461.2
MATCHING RING	509.1
SPACER SLEEVE	525.8
DISK	550.3

DESCRIPTION	PART NO.
SUPPORT WASHER	551.2
SUPPORT WASHER	551.3
COVER DISK	558.1
BLIND RIVET	567.1
NIPPLE JOINT	736.2
HEXAGONAL SCREW	901.3
HEXAGONAL SCREW	901.4
HEXAGONAL SCREW	901.5
HEXAGONAL SCREW	901.6
SCREWED PLUG	903.2
SCREWED PLUG	903.8
SOCKET HEAD CAP SCREW	914.9
IMPELLER NUT	920.1
CIRCLIP	932.1
CIRCLIP	932.5
CIRCLIP	932.11
SPRING WASHER	933.1
KEY	940.1
KEY	940.2
NAME PLATE	971.2

	CONNECTIONS
A	Filling
B	Draining
D	Seepage Drain
E	Venting

DIMENSIONS

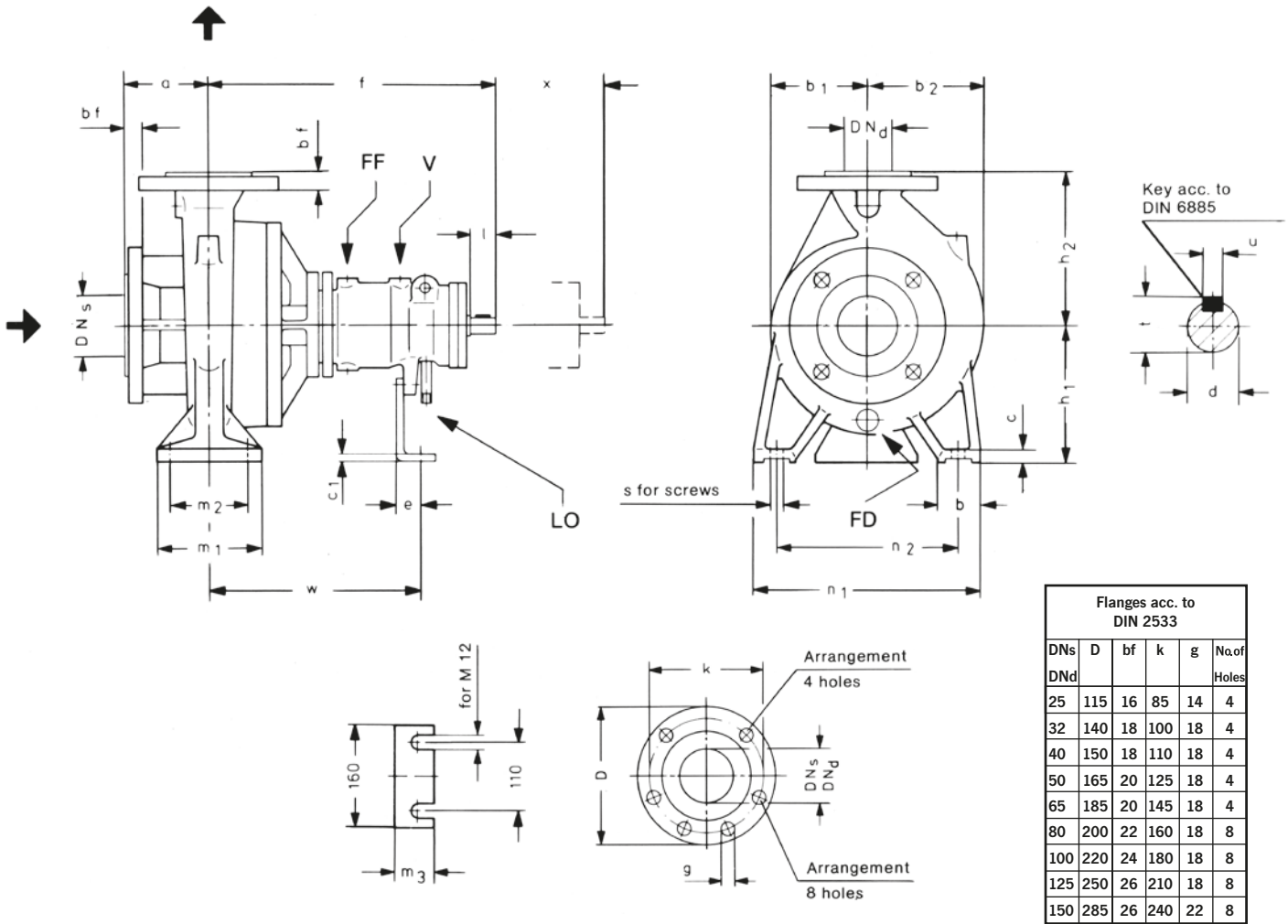

Flanges acc. to DIN 2533					
DNs	D	bf	k	g	No. of Holes
25	115	16	85	14	4
32	140	18	100	18	4
40	150	18	110	18	4
50	165	20	125	18	4
65	185	20	145	18	4
80	200	22	160	18	8
100	220	24	180	18	8
125	250	26	210	18	8
150	285	26	240	22	8

Bearing Bracket size	Pump Size	Pump dimensions																				Connections							
		Flanges		Feet																Back Pull-out Distance	Shaft end acc. to DIN 748				Draining	Filling	Leakage out	Venting	
		DNs	DNd	a	f	b1	b2	h1	h2	b	c	c1	e	m1	m2	m3	n1	n2	w		s	x	d	l					t
360	25-200	40	25	80	360	132	132	160	180	50	15	4	28	100	70	45	240	190	260	M12	80	24	50	27	8	G1/4	G1/4	G1/4	G1/4
	32-160	50	32	80	360	123	123	132	160	50	15	4	28	100	70	45	240	190	260	M12	80	24	50	27	8	G1/4	G1/4	G1/4	G1/4
	40-160	50	32	80	360	123	123	132	160	50	15	4	28	100	70	45	240	190	260	M12	80	24	50	27	8	G1/4	G1/4	G1/4	G1/4
	40-200	65	40	100	360	125	135	160	180	50	15	4	28	100	70	45	265	212	260	M12	80	24	50	27	8	G1/4	G1/4	G1/4	G1/4
	40-250	65	40	100	360	150	156	180	225	65	15	4	28	125	95	45	320	250	260	M12	80	24	50	27	8	G1/4	G1/4	G1/4	G1/4
	50-160	65	50	100	360	125	130	160	180	50	15	4	28	100	70	45	265	212	260	M12	80	24	50	27	8	G1/4	G1/4	G1/4	G1/4
	50-200	65	50	100	360	133	145	160	200	50	15	4	28	100	70	45	265	212	260	M12	80	24	50	27	8	G1/4	G1/4	G1/4	G1/4
	50-250	65	50	100	360	156	169	180	225	65	15	4	28	125	95	45	320	250	260	M12	80	24	50	27	8	G1/4	G1/4	G1/4	G1/4
	65-160	80	65	100	360	133	162	160	200	65	15	4	28	125	95	45	280	212	260	M12	80	24	50	27	8	G1/4	G1/4	G1/4	G1/4
	65-200	80	65	100	360	148	170	180	225	65	15	4	28	125	95	45	320	250	260	M12	100	24	50	27	8	G1/4	G1/4	G1/4	G1/4
470	80-160	100	80	125	360	136	170	180	225	65	15	4	28	125	95	45	320	250	260	M12	100	24	50	27	8	G1/4	G1/4	G1/4	G1/4
	65-250	80	65	100	470	164	184	200	250	80	18	4	28	160	120	45	360	280	340	M16	100	32	80	35	10	G3/8	G1/4	G1/4	G1/4
	80-200	100	80	125	470	163	188	180	250	65	18	4	28	125	95	45	345	280	340	M12	100	32	80	35	10	G3/8	G1/4	G1/4	G1/4
	80-250	80	65	100	470	164	184	200	250	80	18	4	28	160	120	45	360	280	340	M16	100	32	80	35	10	G3/8	G1/4	G1/4	G1/4
	100-200	100	80	125	470	163	188	180	250	65	18	4	28	125	95	45	345	280	340	M12	100	32	80	35	10	G3/8	G1/4	G1/4	G1/4
	100-250	100	80	125	470	182	208	200	280	80	18	4	28	160	120	45	400	315	340	M16	100	32	80	35	10	G3/8	G1/4	G1/4	G1/4
	125-250	125	100	125	470	165	203	200	280	80	18	4	28	160	120	45	360	280	340	M16	120	32	80	35	10	G3/8	G1/4	G1/4	G1/4

TOMBSTONE CURVES

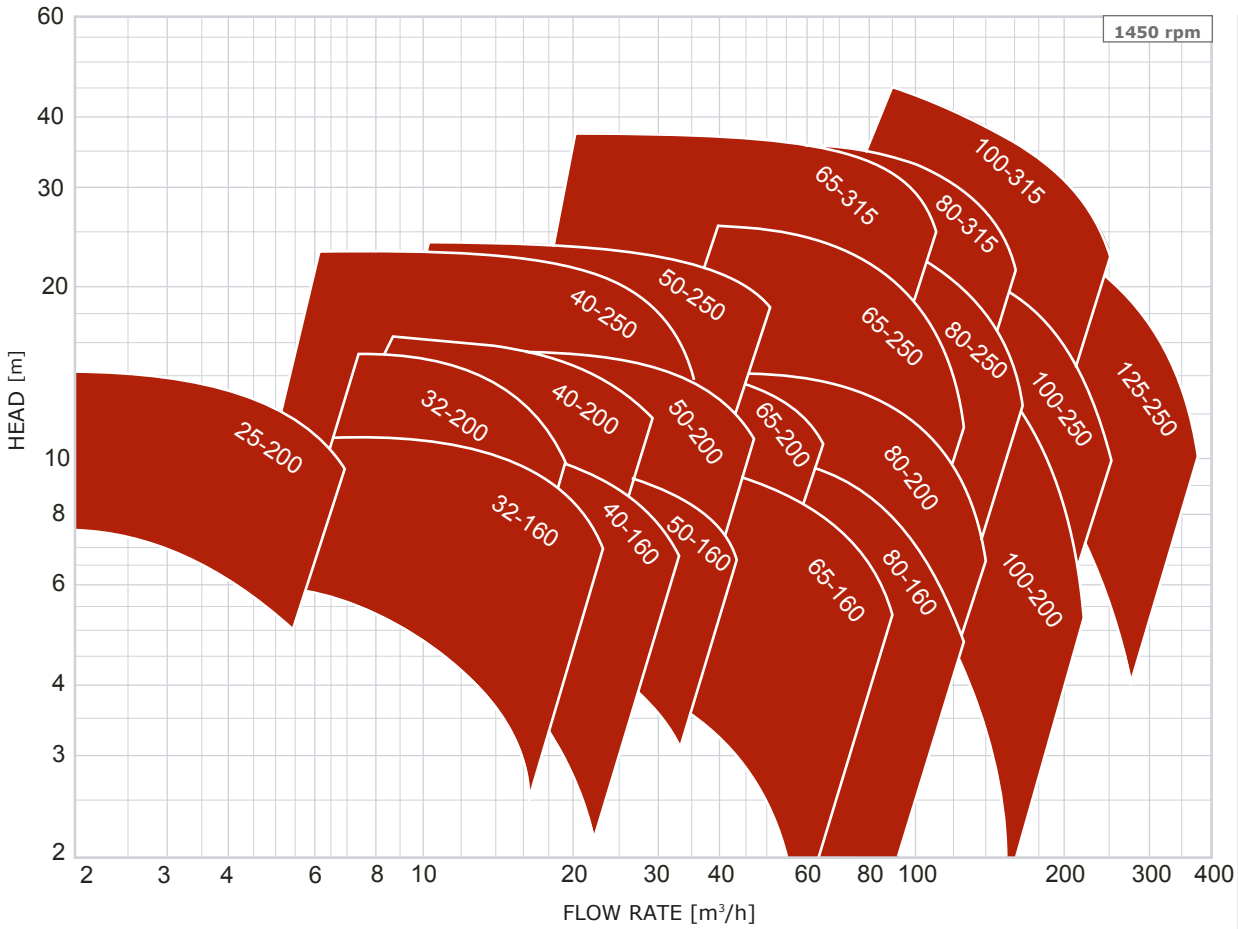

Size*	Pg. no.	
	1450	2900
25-200	3	43
32-160	5	45
32-200	6	46
40-160	8	48
40-200	9	49
40-250	10	50
50-160	12	52
50-200	13	53
50-250	14	54
65-160	16	56
65-200	17	57
65-250	18	58
65-315	19	
80-160	21	59
80-200	22	60
80-250	23	61
80-315	24	
100-200	26	62
100-250	27	63
100-315	28	
125-250	30	64

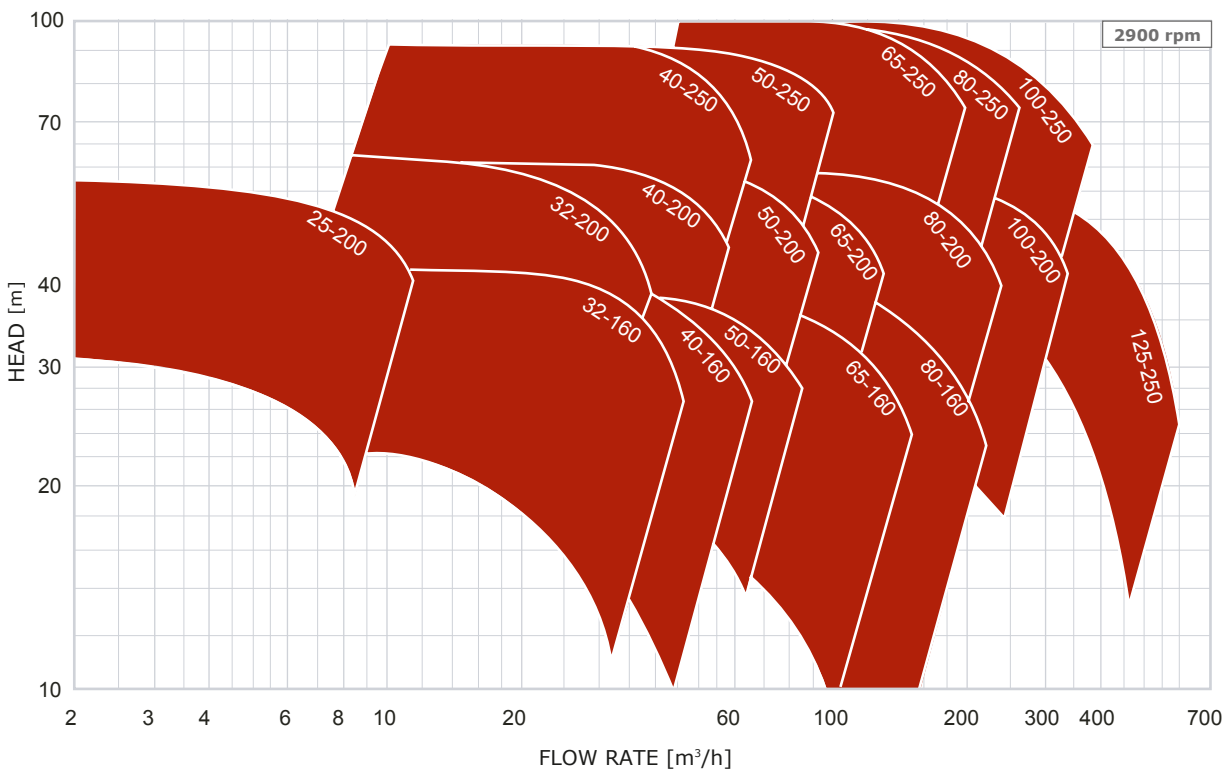

* FOR INDIVIDUAL PUMP PERFORMANCE CURVES, REFER TO OUR 24255 (DIN EN 733) CURVES BOOK.



08600 RAPID

10 Girder Street • Isando • 1601
T: +27 11 573 7400 • **F:** +27 11 974 8757

www.rapidallweiler.co.za